

# AEROTECNICA COLTRI®

[www.aerotecnicacoltri.com](http://www.aerotecnicacoltri.com)



MCH 8-11/EM Compact  
MCH 13-16/ET Compact  
MCH 26-32/ET Compact  
MCH 13-16-18/ET Compact Evo  
MCH 13-16/ET Compact M  
MCH 16/EM Compact E1

USE AND MAINTENANCE MANUAL

# COMPACT

High pressure compressors for pure breathing air and technical gases



**MCH 8-11/EM Compact**  
**MCH 13-16/ET Compact**  
**MCH 26-32/ET Compact**  
**MCH 13-16-18/ET Compact Evo**  
**MCH 13-16/ET Compact M**  
**MCH 16/EM Compact E1**

**HIGH PRESSURE COMPRESSORS FOR PURE BREATHING AIR AND TECHNICAL GASES**

**IMPORTANT**



**BEFORE USING THE COMPRESSOR READ THIS  
MANUAL CAREFULLY**

**AEROTECNICA COLTRI®**

Via Colli Storici, 177  
25010 SAN MARTINO DELLA BATTAGLIA (BS) ITALY  
Tel. +39 030 9910301 Fax. +39 030 9910283  
[www.coltrisub.it](http://www.coltrisub.it) [www.coltrisub.com](http://www.coltrisub.com)  
[coltrisub@coltrisub.it](mailto:coltrisub@coltrisub.it)

Dear Customer,

Thank you for choosing an **AEROTECNICA COLTRI** compressor. This manual is provided together with the compressor to aid you in the use of the machine and ensure that your work produces the best possible results.

Please read all the instructions and information provided on the following pages. Ensure that the manual is at the disposal of the personnel who will be using/managing the compressor and carrying out any maintenance on it.

Should you require any clarification, when using the compressor for the first time or at any other time it is used, please remember that **AEROTECNICA COLTRI** is at your complete disposal.

Should you need to contact us our fax number is: **+39 030 9910283**

For routine or unscheduled maintenance note that **AEROTECNICA COLTRI** international technical service is able to provide you with assistance and spare parts as and when required.

To ensure that your requests are dealt quickly, the following information is provided:

Manufacturer's data:

**AEROTECNICA COLTRI SpA.**

Via Colli Storici, 177

25010 SAN MARTINO DELLA BATTAGLIA (BRESCIA) - ITALY

Tel +39 030 9910301 - +39 030 9910297

Fax +39 030 9910283

<http://www.coltrisub.it> - <http://www.coltrisub.com>

e-mail: [coltrisub@coltrisub.it](mailto:coltrisub@coltrisub.it)

DECLARATION OF CONFORMITY  
Italian DPR 459 of 24<sup>th</sup> July 1996, appendix II, part A

It is hereby declared that the machine model:

**MCH 8-11/EM Compact**  
**MCH 13-16/ET Compact**  
**MCH 26-32/ET Compact**  
**MCH 13-16-18/ET Compact Evo**  
**MCH 13-16/ET Compact M**  
**MCH 16/EM Compact E1**

Serial n° \_\_\_\_\_ year \_\_\_\_\_

complies with

the provisions of Italian DPR 459/96 as per EEC directives 89/392, 93/44 and 93/68 according to the specifications of the following harmonized standards:

EN 292-1 ('91) - EN 292-2 ('91) - EN 60204-1 ('92) - ISO 3746 - ISO 11202

and also complies with

the provisions of Italian Dlgs 476/92 as per EEC directives 89/336 and 92/31 according to the specifications of the following harmonized industrial environment standards:

EN 50081-2 (August 1993)

EN 50082-2 (March 1995)

DESENZANO DEL GARDA, date \_\_\_\_\_

**Chairman of the  
Board of Directors**

*Carlo Coltri*



*This manual is the property of AEROTECNICA COLTRI SpA. Reproduction, whole or partial, is forbidden*

QUICK GUIDE

WARNING



- This guide is intended only as a rapid introduction to use of the compressor.
- This guide is not meant to replace the use and maintenance manual.
- This compressor must not be used before reading the entire use and maintenance manual.

Preliminary tasks:

- Position the compressor in the selected area (see chap "5")
- If necessary connect the air intake extension (see section "5.3.2").
- Check the oil level; if the compressor is new fill the oil sump with the oil supplied with the compressor (see section "7.6").
- Connect the electric motor to the mains power socket (see section "5.3.3");
- For compressors equipped with a three-phase electric motor, check that the cooling fan rotates in the direction indicated by the arrow on the cover; if it turns the other way invert two of the three phases on the mains power (see section "6.1.2").
- Connect up the refill hoses (see section "7.12").
- Check the safety valve is working (see section "7.8");
- Check that compressor shutdown pressure is the same as the pressure set on the pressure switch (See Chap."6.4.");

Bottle refill (see section "6.6"):

- fit the hose connector 1 on the bottle connector 3 (closed) (A);
- open the condensate discharge valve 2 and bottle valve 4;
- start the compressor (B);

Once refilling has been completed wait for automatic shutdown of the compressor with the pressure switch:

- close filling valve 2 and tank valve 4 (A);
- bleed the pressure from the filling valve via the bleed valve 5 (A);
- disconnect the connector 1 from the bottle (A).

Maintenance:

- After the first 50 working hours change the oil again (see section "7.6.3").
- Check the lubricating oil level every 5 hours (see section "7.6.2").
- Change the lubricating oil every 250 hours (see section "7.6.3").
- Periodically change the air intake filter (see section "7.7").
- Check the safety valve at every refill (see section "7.8").
- Check transmission belt tension and if necessary change them (see section "7.10").
- Discharge the condensate (see section "7.9").
- Periodically replace the active carbon filters / molecular sieve (see section "7.11").
- Periodically replace the refill hoses (see section "7.12").

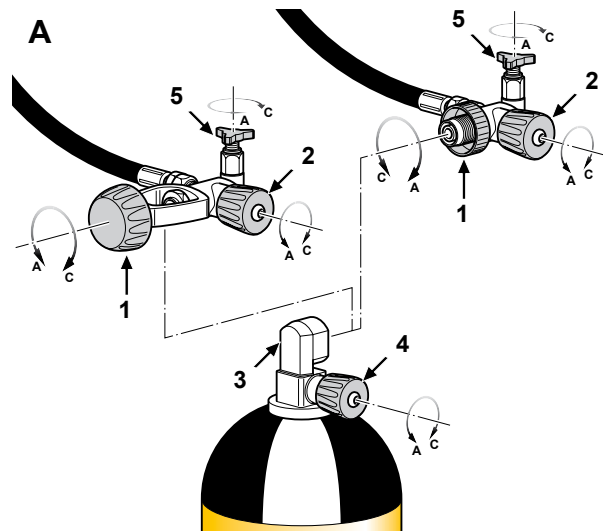

Model: Compact

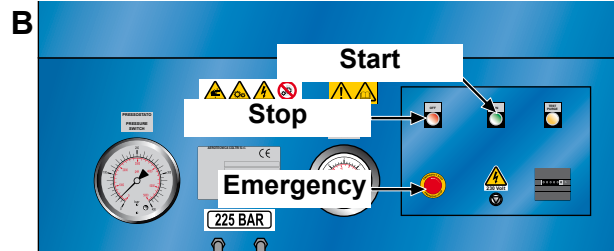

Model: Compact M

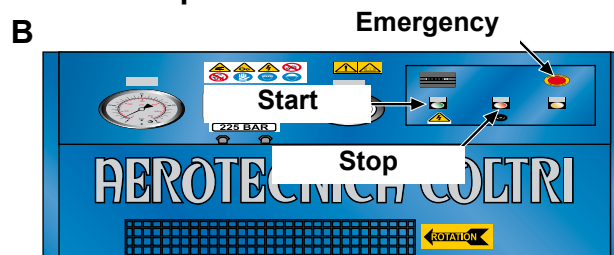

Model: Compact Evo

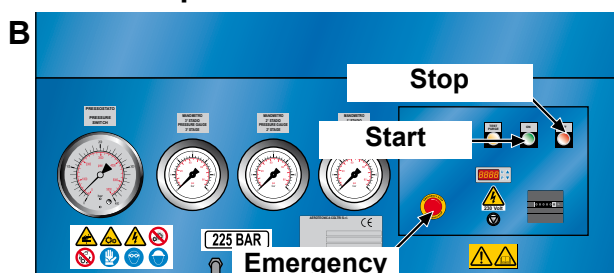

## CONTENTS

<b>CHAPTER 1 – GENERAL</b>	<b>10</b>
1.1 Preliminary information	10
1.2 Required operator training	10
1.3 Important information for the user	11
1.4 Foreword	12
1.5 Warranty	12
1.6 Assistance	13
1.7 Responsibility	13
1.8 Purpose of the machine	14
1.9 Where the machine may be used	16
1.10 Running in and testing the compressor	16
1.10.1 Tightening torque values	16
<b>CHAPTER 2 – BASIC INFORMATION ON THE COMPRESSOR</b>	<b>17</b>
2.1 Description of the compressor	17
2.2 Identification the compressor	17
2.3 General instructions	18
<b>CHAPTER 3 – SAFETY REGULATIONS</b>	<b>19</b>
3.1 General safety rules	19
3.1.1 Know the machine	19
3.1.2 Protective clothing	19
3.1.3 Emergency equipment	19
3.1.4 Checks and maintenance	19
3.2 General precautions	20
3.2.1 Important safety information	21
3.2.2 Accident prevention	21
3.2.3 Working safety	21
3.2.4 Noise level	21
3.2.5 Residual risk zones	22
3.3 Safety info labels: location	23
3.3.1 Safety info labels: description	24
3.4 General safety regulations	27
3.4.1 Care and maintenance	27
3.4.2 Fire extinguishers and first aid	27
3.5 Maintenance precautions	28
3.5.1 Warning signs	28
3.5.2 Tools	28
3.5.3 Personnel	28
3.5.4 Keeping the compressor clean	28
3.5.5 Periodic replacement of essential safety parts	28
<b>CHAPTER 4 – TECHNICAL DATA</b>	<b>29</b>
4.1 Technical characteristics	29
4.1.1 Crankcase, crankshaft, cylinder, pistons	29
4.1.2 Valves	29
4.1.3 Safety valves	29
4.1.4 Pressure maintenance valve	29
4.1.5 Lubrication	29
4.1.6 Cooling tubes	29
4.1.7 Frame, guards	29
4.2 Machine parts	30

4.3 Technical characteristics	31
4.3.1 MCH 8-11/EM Compact	31
4.3.2 MCH 13-16/ET Compact	32
4.3.3 MCH 26-32/ET Compact	33
4.3.4 MCH 13-16-18/ET Compact Evo	34
4.3.5 MCH 13-16/ET Compact M	35
4.3.6 MCH 16/EM Compact E1	36
4.4 Pressure circuit	37
<b>CHAPTER 5 – HANDLING AND INSTALLATION</b>	<b>38</b>
5.1 Unpacking	38
5.2 Handling	38
5.3 Installation	38
5.3.1 Positioning	38
5.3.2 Air intake extension connection	39
5.3.3 Electrical connection	40
<b>CHAPTER 6 – USING THE COMPRESSOR</b>	<b>41</b>
6.1 Preliminary checks before using for the first time	41
6.1.1 Filling with lubricating oil	41
6.1.2 Checking for proper electrical connection	41
6.2 Checks to be run at the start of each working day	41
6.2.1 Lubricating oil level check	41
6.2.2 Checking that the flex hoses are in good condition	42
6.2.3 Storing technical documentation	42
6.3 Preliminary tasks	42
6.3.1 Checking the safety valves	42
6.4 Control panel	43
6.5 Starting and shutting down	45
6.6 Tank refill	46
<b>CHAPTER 7 – MAINTENANCE</b>	<b>48</b>
7.1 Foreword	48
7.2 General	48
7.3 Unscheduled work	48
7.4 Scheduled maintenance table	49
7.5 Troubleshooting	49
7.6 Checking and changing the lubricating oil	50
7.6.1 Oil table	50
7.6.2 Checking the oil level	50
7.6.3 Changing the lubricating oil	51
7.7 Changing the intake filter	52
7.8 Checking the safety valve	52
7.9 Condensate discharge	53
7.10 Transmission belt	54
7.10.1 Checking transmission belt tension	54
7.10.2 Changing transmission belt	54
7.11 Active carbon filter / molecular sieve	55
7.11.1 Filter replacement frequency calculation table	55
7.11.2 Changing the active carbon filter / molecular sieve	55
7.12 Changing the flex hoses	57



<b>CHAPTER 8 – STORAGE</b>	<b>58</b>
8.1 Stopping the machine for a brief period	58
8.2 Stopping the machine for a long period	58
<b>CHAPTER 9 – DISMANTLING AND PUTTING OUT OF SERVICE</b>	<b>59</b>
9.1 Waste disposal	59
9.2 Dismantling the compressor	59
<b>CHAPTER 10 – INSTRUCTIONS FOR EMERGENCY SITUATIONS</b>	<b>59</b>
10.1 Fire	59
<b>CHAPTER 11 – MAINTENANCE REGISTER</b>	<b>60</b>
11.1 Assistance service	60
11.2 Scheduled maintenance	60
11.3 Using the compressor under heavy-duty conditions	60
11.4 The Customer Care Centre	60
11.5 Scheduled maintenance registry coupons	61
<b>CHAPTER 12 - NOTES</b>	<b>64</b>

## 1 – GENERAL

### 1.1 PRELIMINARY INFORMATION

Do not destroy or modify the manual and update it with inserts published by producer only.

Machine type: High pressure compressor for breathing air and/or technical gases

Model: **MCH 8-11/EM Compact**  
**MCH 13-16/ET Compact**  
**MCH 26-32/ET Compact**  
**MCH 13-16-18/ET Compact Evo**  
**MCH 13-16/ET Compact M**  
**MCH 16/EM Compact E1**

Revision n°: 00

Manual version: 10/2008

Manufacturer's data: **AEROTECNICA COLTRI SpA**  
Via Colli Storici, 177  
25010 SAN MARTINO DELLA BATTAGLIA (BRESCIA) - ITALY  
Telefono : +39 030 9910301 - +39 030 9910297  
Fax +39 030 9910283  
<http://www.coltrisub.it> - <http://www.coltrisub.com>  
e-mail: [coltrisub@coltrisub.it](mailto:coltrisub@coltrisub.it)

Appendices:

- Safety regulations

### 1.2 REQUIRED OPERATOR TRAINING

This manual must be read carefully:

- all compressor operators / maintenance personnel must read this entire manual with due care and attention and observe the instructions/information contained herein.
- Company owners must ensure that the operator has the required training for operation of the compressor and that he/she has read the manual.

### 1.3 IMPORTANT INFORMATION FOR THE USER

The information/instructions for compressor use contained in this manual only concern the:  
**AEROTECNICA COLTRI Mod.:**

**MCH 8-11/EM Compact**  
**MCH 13-16/ET Compact**  
**MCH 26-32/ET Compact**  
**MCH 13-16-18/ET Compact Evo**  
**MCH 13-16/ET Compact M**  
**MCH 16/EM Compact E1**

The instruction manual must be read and used as follows:

- read this manual carefully, treat it as an essential part of the compressor;
- the instruction manual must be kept where it can readily be consulted by compressor operators and maintenance staff;
- keep the manual for the working life of the compressor;
- make sure updates are incorporated in the manual;
- make sure the manual is given to other users or subsequent owners in the event of resale;
- keep the manual in good condition and ensure its contents remain undamaged;
- do not remove, tear or re-write any part of the manual for any reason;
- keep the manual protected from damp and heat;
- if the manual is lost or partially damaged and its contents cannot be read it is advisable to request a copy from the manufacturer.

Important: you must understand the following symbols and their meaning.  
 They highlight essential information:

#### IMPORTANT

Refers to additional information or suggestions for proper use of the compressor.



#### DANGER

Refers to dangerous situations that may occur during use of the compressor: aims to ensure worker safety.



#### WARNING

Refers to dangerous situations that may occur during use of the compressor: aims to prevent damage to objects and the compressor itself.



## 1.4 FOREWORD

The regulations/instructions for use contained in this manual constitute an essential component of the supplied compressor.

These regulations/instructions are intended for an operator who has already been trained to use this type of compressor. They contain all the information necessary and essential to safety and efficient, proper use of the compressor.

Hurried or careless preparation leads to improvisation, which is the cause of accidents.

Before beginning work, read the following suggestions carefully:

- 1) before using the compressor, gain familiarity with the tasks to be completed and the admissible working position;
- 2) the operator must always have the instruction manual to hand;
- 3) program all work with due care and attention;
- 4) you must have a detailed understanding of where and how the compressor is to be used;
- 5) before starting work make sure that safety devices are working properly and that their use is understood; in the event of any doubts do not use the compressor;
- 6) observe the warnings given in this manual with due care and attention;
- 7) constant and careful preventive maintenance will always ensure a high level of safety when using the compressor. Never postpone repairs and have them carried out by specialised personnel only; use only original spare parts.

## 1.5 WARRANTY

### IMPORTANT



The materials supplied by AEROTECNICA COLTRI SpA are covered by a 1 year warranty, the validity of which begins when the compressor is put into service as proven by the delivery document.

AEROTECNICA COLTRI SpA shall repair or replace those parts it acknowledges to be faulty during the warranty period.

In replacing the faulty part AEROTECNICA COLTRI SpA shall not be liable for any other expenses sustained by the dealer or his customer such as presumed damage (present or future), lost earnings or fines.

Routine and unscheduled maintenance must be carried out in compliance with the instructions contained in this manual. Should the required work not be covered by the manual or assistance be required you are advised to contact AEROTECNICA COLTRI SpA in writing, even where agreements have already been made on the phone. AEROTECNICA COLTRI SpA cannot be held liable for any delays or failure to execute work.

AEROTECNICA COLTRI SpA cannot be held liable for any damage or malfunctions caused by work carried out on the compressor by unauthorised personnel.

AEROTECNICA COLTRI SpA guarantees that its compressors are free from defects design, workmanship and the used materials for a period of 1 year starting from the date of delivery of the compressor; should the customer note any flaws and/or defects he must report them, in writing, to AEROTECNICA COLTRI SpA within 8 days of their discovery otherwise the warranty shall be rendered null and void.

The warranty only covers flaws and faults that occur where the compressor is used properly in compliance with the instructions contained in this manual and where periodic maintenance is carried out.

The warranty does not cover faults caused by improper use of the compressor, exposure to atmospheric agents (rain etc.) or damage during transport; all materials subject to wear and those subject to periodic maintenance are not covered by the warranty and are to be paid for by the customer in full; in any event the warranty is rendered null and void if the compressor is tampered with or if work is carried out on it by personnel who have not been authorised by AEROTECNICA COLTRI SpA.

A compressor that has been acknowledged as faulty on account of flaws in design, workmanship or used materials shall be repaired or replaced free of charge by **AEROTECNICA COLTRI SpA** at its plant in San Martino della Battaglia (BRESCIA); costs regarding transport, delivery of spare parts and any materials subject to wear shall be met by the customer.

Should warranty-covered work need to be carried out on the customer's premises, travel and accommodation costs for personnel sent by **AEROTECNICA COLTRI SpA** shall be met by the customer.

The act of taking delivery of machines and/or faulty components or the sending of technicians to assess the presumed defects and/or flaws reported by the customer does not in itself imply acknowledgement that the defect is covered by warranty.

Repairs and/or replacements made by **AEROTECNICA COLTRI SpA** during the warranty period do not in any way prolong the latter itself.

Acknowledgement that a defect is covered by warranty does not in itself mean that **AEROTECNICA COLTRI SpA** is in any way liable to award compensation.

**AEROTECNICA COLTRI SpA** cannot be held liable for any other direct or indirect damages imputable to compressor defects and flaws (loss of production or earnings etc.) except in cases where serious negligence is demonstrated.

## 1.6 ASSISTANCE

**AEROTECNICA COLTRI SpA** technicians are at your disposal for all routine/unscheduled maintenance work.

Please forward your request for assistance to **AEROTECNICA COLTRI SpA** by sending a fax or e-mail to:

Fax +39 030 9910283

coltrisub@coltrisub.it

## 1.7 RESPONSIBILITY

**AEROTECNICA COLTRI SpA** considers itself exonerated from any responsibility or obligation regarding injury or damage caused by:

- failure to observe the instructions contained in this manual that concern the running, use and maintenance of the compressor;
- violent actions or incorrect manoeuvres during use or maintenance of the compressor;
- modifications made to the compressor without prior written authorisation from **AEROTECNICA COLTRI SpA**;
- incidents beyond the scope of routine, proper use of the compressor.

In any case, should the user impute the incident to a defect of the compressor, he/she must demonstrate that the damage has been a major and direct consequence of this "defect".

### WARNING



**Maintenance and repairs must only be carried out using original spare parts.**

**AEROTECNICA COLTRI SpA cannot be held liable for any damages caused by failure to observe this rule.**

**The compressor is guaranteed as per the contractual agreements made at the time of sale.**

**Failure to observe the regulations and instructions for use contained in this manual shall render the warranty null and void.**

## 1.8 PURPOSE OF THE MACHINE

The compressors mod. **COMPACT** have been designed and built for the purpose of obtaining excellent quality breathing air by drawing it from the surrounding environment. The air, free from any harmful fumes, is passed through an intake filter and, after the filtration cycle, is stored in bottles constructed to contain air at high pressure.

The compressor can also be used to obtain other non-breathable gases for industrial use such as:

- Nitrogen
- Helium
- Nitrox 40% max O<sub>2</sub>

Any other use is inappropriate: the manufacturer cannot be held liable for any personal injury or damage to objects / the machine itself caused by improper use.

### DANGER



- Use only tested, certified bottles: do not exceed the working pressure indicated on them.

- Aspirate unpolluted air.

Use the compressor in areas free from dust, risk of explosion, corrosion and fire.

- Improper use could have serious consequences for the user .

- Do not disconnect the hose from the fittings or the clamp when it is under pressure.
- Change the air purification filters regularly as described in section “7.11.2 Changing the active carbon filters”.
- Drain the condensate regularly as illustrated in section “7.9 Condensate discharge”.
- The power lead plug must be disconnected:
  - if there is a problem during use
  - before carrying out any cleaning or maintenance tasks.
- Never pull the plug out by tugging the lead. Make sure the lead is not bent at a sharp angle and that it does not rub against any sharp edges. Use of extensions is not recommended.
- Never run the compressor when:
  - the power lead is damaged;
  - there is evident damage;
  - the covers/guards are removed.
- All routine and unscheduled maintenance tasks must be carried out with the compressor at standstill, the electrical power supply disconnected and the pumping circuit depressurised.
- After switching off the compressor wait about 30 minutes before carrying out any maintenance tasks so as to prevent burns.
- The high pressure flex hose that connects to the bottle (also called the refill hose) must be in good condition, especially in the areas near the fittings.
 

The plastic sheath that covers the pipe must not show any signs of abrasion otherwise damp could get in, corrode the steel braid and weaken it.

The hose must be changed periodically (yearly) or when it shows signs of wear.

Failure to observe this rule could seriously endanger the users' safety.

Make sure the minimum bending radius of the hose is no less than 250 mm.

To ensure maximum working efficiency, **AEROTECNICA COLTRI** has constructed the compressor with carefully selected components and materials. The compressor is tested prior to delivery. Continued compressor efficiency over time will also depend on proper use and maintenance as per the instructions contained in this manual.

All the components, connections and controls used in its construction have been designed and built to a high degree of safety so as to resist abnormal strain or in any case a strain greater than that indicated in the manual. Materials are of the finest quality; their introduction and storage in the company and their utilisation in the workshop are controlled constantly so as to prevent any damage, deterioration or malfunction.

**DANGER**

- Before carrying out any work on the compressor each operator must have a perfect understanding of how the compressor works, know how to use the controls and have read the technical information contained in this manual.

- It is forbidden to use the compressor under conditions / for purposes other than those indicated in this manual and **AEROTECNICA COLTRI** cannot be held liable for breakdowns, problems or accidents caused by failure to observe this rule.
- Check that the fittings provide a proper seal by wetting them with soapy water: eliminate any leaks.
- Do not attempt to repair high pressure hoses by welding them.
- Do not empty the bottles completely, not even during winter storage, so as to prevent damp air getting in.
- It is forbidden to tamper with, alter or modify, even partially, the systems and equipment described in this instruction manual, especially as safety guards and safety symbols are concerned.
- It is also forbidden to carry out work in any way other than that described or to neglect the illustrated safety tasks.
- The safety information and the general information given in this manual are highly important.

**1.9 WHERE THE MACHINE MAY BE USED**

The compressors mod. **COMPACT** have been designed and built for the purpose of obtaining excellent quality breathing air by drawing it from the surrounding environment. The air, which must be free from any harmful fumes, is passed through an intake filter and, after the filtration cycle, is stored in bottles constructed to contain air at high pressure. The compressor must only be used in environments having the characteristics described in the following table.

AREA OF MACHINE USE: ESSENTIAL DATA TABLE		
Temperature ambient	(°C) / (°F)	min.+5°C - Max.+45°C / min.+41°F - Max.+113°F
Air humidity	(%)	<b>max.80%</b>
Tolerated weather conditions	rain	<b>None</b>
	hail	
	snow	
Max tilt angle (bank)	%	<b>6</b>

Check that the area in which the compressor is to be positioned is adequately ventilated: good air exchange with no dust and no risk of explosion, corrosion or fire.

If ambient temperatures exceed 45°C air conditioning will be required.

Make sure that lighting in the area is sufficient to identify every detail (such as the writing on the info plates/stickers); use artificial lighting where daylight on its own is insufficient.

**1.10 RUNNING IN AND TESTING THE COMPRESSOR**

Each compressor is carefully run and tested prior to delivery.

A new compressor must nevertheless be used with caution during the first 5 working hours so as to complete proper running in of its components.

If the compressor is subject to an excessive workload during initial use, its potential efficiency will be prematurely compromised and functionality soon reduced. During the running in period proceed as follows:

After the first 5 hours carry out - in addition to the scheduled maintenance - the following tasks:

- change the compressor oil;
- check and adjust nuts and bolts.

**1.10.1 Tightening torque values**

The table shows tightening torques for bolts or hexagonal-head screws or socket screws lubricated with grease, except for specific cases indicated in the manual. Pipe connections (swivel nuts) should be finger tight plus an additional 1/2 turn.

Tightening torque values	
Thread	Max. torque
M6 - 1/4"	<b>10Nm (7ft-lbs)</b>
M8 - 5/16"	<b>25Nm (18ft-lbs)</b>
M10 - 3/8"	<b>45Nm (32ft-lbs)</b>
M12 - 1/2"	<b>75Nm (53ft-lbs)</b>
M14 - 9/16"	<b>120Nm (85ft-lbs)</b>
M16 - 5/8"	<b>200Nm (141ft-lbs)</b>

**6 bolt and 4 bolt torque sequence**

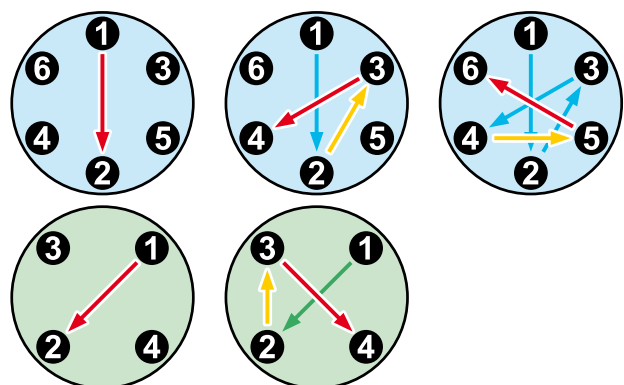



**2 - BASIC INFORMATION ON THE COMPRESSOR**

**2.1 DESCRIPTION OF THE COMPRESSOR**

High pressure compressor for breathing air and technical gases.

Compatible process gases:

- Nitrogen
- Helium
- Nitrox 40% max O<sub>2</sub>



**DANGER**



The compressor may be used together with Nitrox mixers up to a maximum of 40% oxygen and only with certified systems that feature an alarm system and that prevent the introduction of oxygen percentages above the permitted maximum and/or incorrect mixes.

**2.2 IDENTIFICATION THE COMPRESSOR**

Each compressor has an identification label (a) attached to its frame.



<b>AEROTECNICA COLTRI SpA</b> Via Colli Storici 177 25010 DESENZANO D/G (BS) ITALY Tel. 030/9910301-9910297 Fax. 030/9910283		
MODEL	MCH 13-16/ET COMPACT	
TYPE	SC000296	
S/N.	0010	
YEAR	2008	
MOTOR	ELECTRIC THREEPHASE	
POWER	4KW	

## 2.3 GENERAL INSTRUCTIONS

### WARNING



- This manual must be read carefully before transporting, installing, using or carrying out any maintenance on the compressor.
- It must be preserved carefully in a place known to compressor users, managers and all transport/installation/maintenance/repair/final dismantling personnel.
- This manual indicates the purposes for which the compressor can be used and gives instructions for its transport, installation, assembly, adjustment and use. It also provides information on maintenance tasks, ordering spare parts, residual risks and staff training.
- It should be born in mind that the use and maintenance manual can never replace proper experience; some maintenance jobs are particularly difficult and in this regard the manual only offers general guidelines on the most important tasks, which must be carried out by personnel with proper training (e.g. acquired during training courses run by the manufacturer).
- This manual is an integral part of the compressor and must be stored in a suitable container near the compressor until its final demolition. If the manual is lost or damaged a copy can be requested from the manufacturer.
- Make sure all users have understood the regulations for use and the meaning of the symbols on the compressor.
- Observance of these technical instructions can prevent accidents: instructions have been drawn up in compliance with EEC Machinery Directive 89/392 and subsequent amendments.
- In any case always observe national safety regulations.
- Do not remove or damage guards, labels or notices, especially those required by law.
- The adhesives attached to the compressor are there for safety purposes. They must be replaced if they become illegible.
- This manual reflects the technical knowledge available at the time the compressor was sold and cannot be considered inadequate simply because updated at a later time on the basis of new experience.
- The manufacturer reserves the right to update products and manuals, without any obligation to update preceding products or manuals except in exceptional circumstances.
- To request or receive any updates or additions to this use and maintenance manual (which shall be considered an integral part of the manual) apply via the contact numbers given in section "1.6 Assistance".
- Should you have any other queries or suggestions as to how to improve the manual please contact the manufacturer.
- Should you sell the compressor AEROTECNICA COLTRI invites you to provide us with the details of the new owner so that any new additions to the manual can be sent on.

## 3 - SAFETY REGULATIONS

### 3.1 GENERAL SAFETY RULES

#### 3.1.1 Know the machine

The compressor must only be used by qualified personnel. They must have an understanding of the arrangement and function of all the controls, instruments, indicators, warning lights and the various info plates/labels.

#### 3.1.2 Protective clothing

All operators must use accident prevention items such as gloves, hard hat, eye goggles, accident prevention shoes and ear defenders against noise.



#### 3.1.3 Emergency equipment

Make sure a first aid cabinet and a CO<sub>2</sub> fire extinguisher are near the compressor. Keep the extinguisher fully loaded. Use according to standards in force.



#### 3.1.4 Checks and maintenance

Apply a sign with the legend **“WORK IN PROGRESS”** on all sides of the compressor. Inspect the compressor carefully every day it is used as per the check list given in this manual.



### 3.2 GENERAL PRECAUTIONS

- The EEC Machinery Directive 89/392 provides the following definitions (appendix 1, 1.1.1):
  - «**DANGEROUS ZONE**»: any zone in side and/or near a machine in which the presence of an exposed person constitutes a risk for his/her security and health.
  - «**EXPOSED PERSON**»: any person wholly or partially inside a dangerous zone.
  - «**OPERATOR**»: the person(s) charged with th e task of installing, running, maintaining, cleaning, repairing and transporting the machine.

#### IMPORTANT



- Before carrying out any task or operation with the compressor it is compulsory to read and follow the instructions given in the use and maintenance manual. Doing so during work is too late: improper use or an erroneous manoeuvre could cause serious damage or injury.
- The employer must provide workers with detailed information on the risk of accident, especially risks deriving from noise, use of safety devices and the general accident prevention regulations provided for by international laws or standards or national standards within the country of use. All operators must observe both international accident prevention standards and the national ones relevant to the country of use. Bear in mind that the European Union has issued directives concerning worker health and safety: these include EEC directives 89/391, 89/686, 89/654, 89/655, 89/656, 86/188, 92/58 and 77/576 which all employers are legally obliged to comply with.
- Before carrying out any work on the compressor each operator must have a perfect understanding of how the compressor works, know how to use the controls and have read the technical information contained in this manual.

#### WARNING



It is forbidden to tamper with or replace compressor parts without obtaining prior authorisation from AEROTECNICA COLTRI.

The use of accessories, tools, materials subject to wear or spare parts other than those recommended by the manufacturer and/or illustrated in this manual can constitute a source of danger to operators and/or damage the machine.

Any modification to the compressor that has not been expressly authorised by AEROTECNICA COLTRI shall exonerate the manufacturer from any civil or penal liability.

#### IMPORTANT



- Removing or tampering with any safety device is strictly forbidden.
- All installation, routine or unscheduled maintenance work must be carried out with the compressor at standstill and disconnected from the electrical power supply.
- Once the compressor has been cleaned the operator must check for any worn, damaged or loose parts; in this case seek assistance from the maintenance technician. It is especially important to check that flex hoses or other parts subject to wear are in good condition. Check also for any leaking of oil or other dangerous substances. If such situations arise it is forbidden to restart the compressor before the situation is resolved. If these problems are observed at the end of the refilling the operator must, before leaving the machine unattended, place a sign on the compressor indicating that maintenance work is in progress and that it must not be restarted.

**IMPORTANT**

- Never place hands or introduce screwdrivers, keys or other tools into moving parts.
- Never clean with flammable fluids.
- Periodically check the info plates/labels and restore/replace them where necessary.
- The workplace must be kept clean, tidy and free from objects that might hinder movement.
- Operators must avoid carrying out “awkward” tasks in uncomfortable positions that might cause imbalance.
- Operators should be aware of the risk of entrapment caused by clothes or hair getting caught up in moving parts; wear a cap to contain long hair.
- Necklaces, bracelets and rings can also be a source of danger.
- Workplace lighting must be adequate for the work in progress. Insufficient or excessive lighting can generate risks.
- Always observe the instructions, accident prevention regulations and the warnings contained in this manual.

### 3.2.1 Important safety information

The compressor has been designed and built according to the state of the art and complies with technical regulations in force concerning compressors for the production of high pressure breathing air. The laws, regulations, standards and directives in force for such machines have been complied with.

Materials, parts, production procedures and quality controls all comply with the strictest safety and reliability standards.

Using the compressor for the purposes described in this manual, handling it with due diligence and carrying out maintenance and overhauls according to proper working practices will ensure long lasting performance and functionality.

### 3.2.2 Accident Prevention

The manufacturer cannot be held liable for accidents that occur during use of the compressor as a result of the user's non-observance of the laws, regulations, standards and directives in force for high pressure compressors. The compressor has been designed for use in weather conditions as refer to “1.9 Where the machine may be used”.

### 3.2.3 Working safety

The manufacturer cannot be held liable for malfunction or damage if the compressor:

- is used for purposes other than that for which its is intended;
- is not handled or maintained according to the instructions specified in this manual;
- is not periodically and continually maintained as instructed or if non-original spare parts are used;
- machine parts are modified or replaced without written authorisation from the manufacturer, especially where the efficiency of safety devices has been reduced or eliminated;
- where it is used outside the admissible temperature range.

### 3.2.4 Noise level

**WARNING**

Should the compressor be used where the daily noise exposure level is greater than 80 dBA, the employer must apply all the relevant worker health and safety measures. Where necessary operators must use personal protection such as ear defenders.

### 3.2.5 Residual risk zones

#### DANGER



In some compressor zones there remain residual risks that were not possible to eliminate at the design stage or for which safety guards could not be provided without compromising the functionality of the compressor.

To prevent accidents all operators must be aware of the residual risks on this compressor.

Residual risk zones:

- 1 Danger of polluting the produced air due to the possibility of mixing exhaust fumes or lubricating oil vapours with the compressed air being produced.
- 2 Electrical dangers. Use the machine with suitable insulation, especially against water and humidity.
- 3 Heat-related dangers in compressor zone. Use the machine with suitable safety devices and after switching off the machine wait 30 minutes for the machine to cool down before carrying out maintenance work.
- 4 Danger deriving from noise emitted by the compressor.
- 5 Fire risk.
- 6 Risk of being crushed or dragged in the transmission belt zone.
- 7 Danger of impact/abrasion with the cooling fan.
- 8 Danger of direct contact on the part of the operator in the event of disassembly with the compressor at pressure.

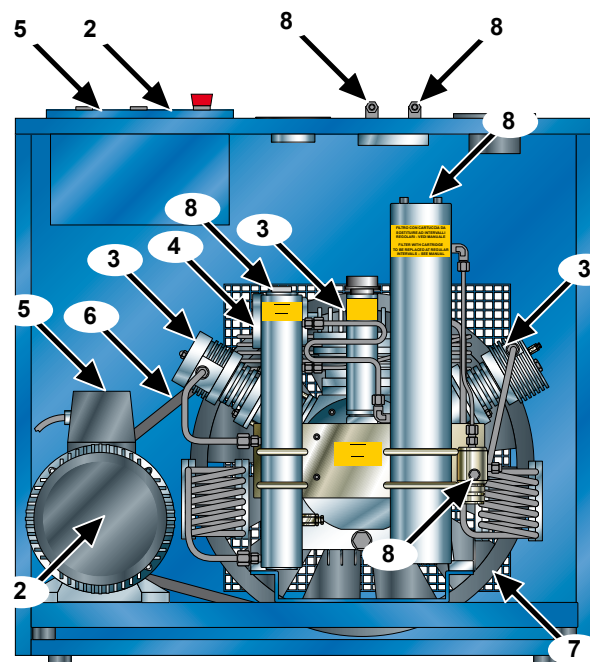
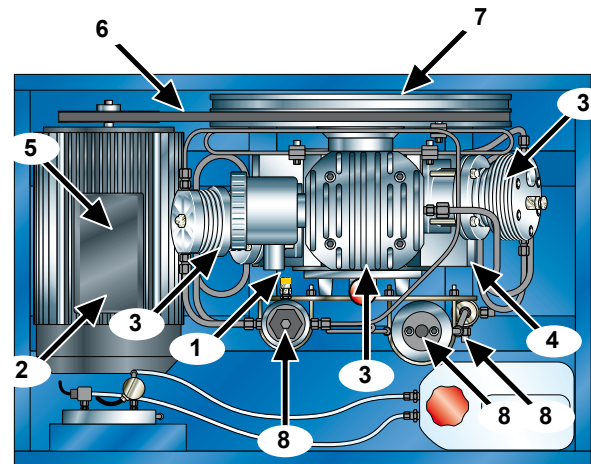



3.3 SAFETY INFO LABELS: LOCATION

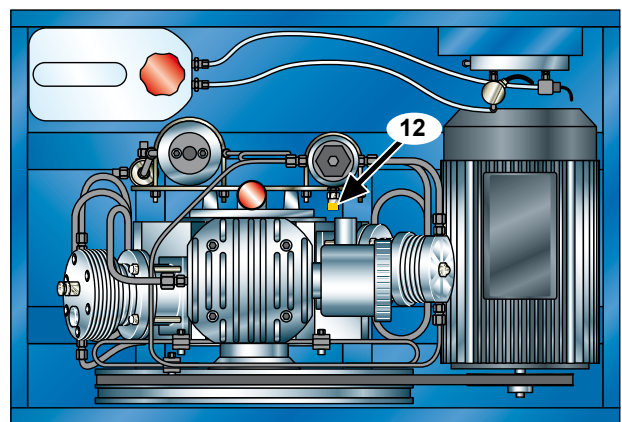
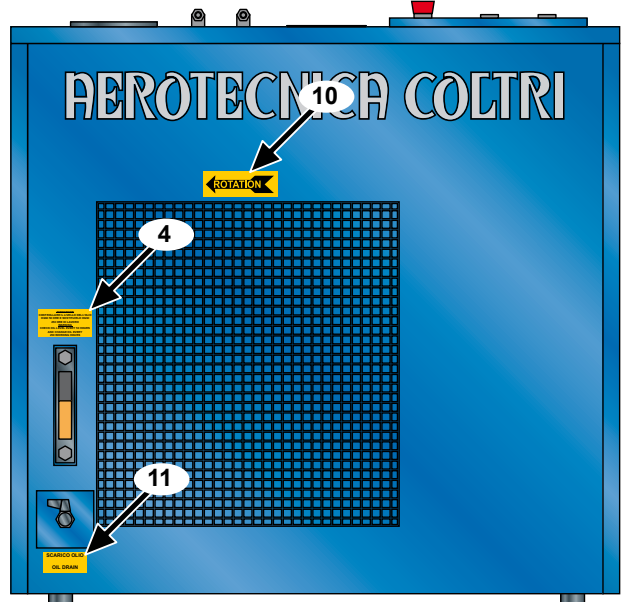
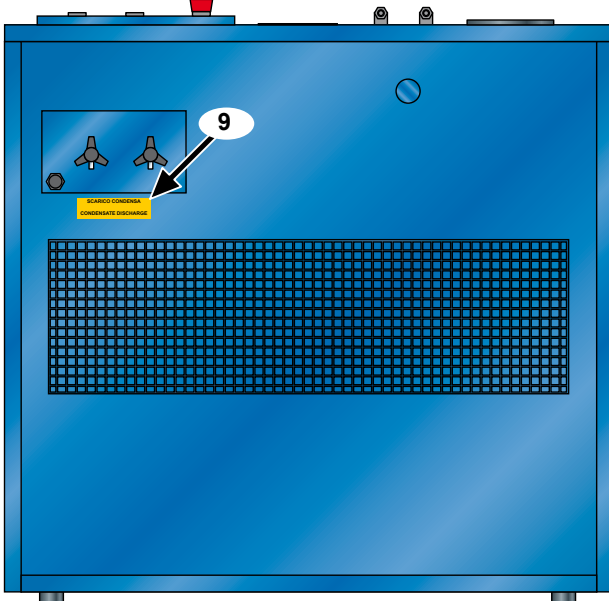
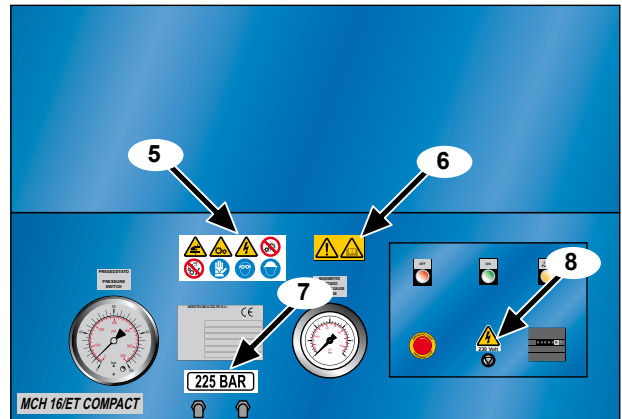
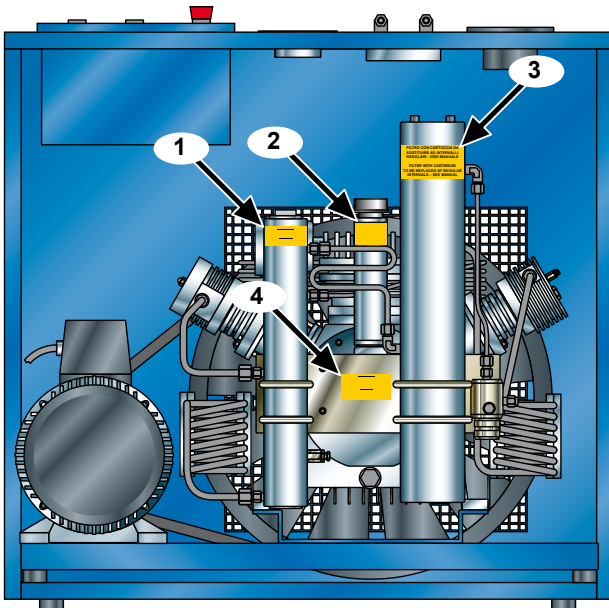

### 3.3.1 Safety info labels: description

— 1

**a** Condensate separator info label.  
Indicates that the condensate must be emptied via the drain valves every 10-15 minutes.

**ATTENZIONE**  
**SEPARATORE DI CONDENSA**  
**SCARICARE OGNI 10-15 MINUTI**  
**WARNING**  
**CONDENSATE SEPARATOR**  
**EMPTY EVERY 10-15 MINUTES**

#### IMPORTANT

Except for version with automatic condensate discharge.



— 2

Special oil info plate.  
Indicates that only special oils must be used for high pressure compressors.  
To choose the right oil see section “7.6.1 Oil table”.

**USARE OLIO SPECIALE**  
**PER COMPRESSORI AD**  
**ALTA PRESSIONE**

**USE SPECIAL OIL**  
**FOR HIGH PRESSURE**  
**COMPRESSORS**

— 3

Cartridge change info label.  
Filter with active carbon molecular sieve cartridge.  
To change the filter refer to “7.11.1 Filter replacement frequency calculation table” and “7.11.2 Changing the active carbon filters”.

**FILTRO CON CARTUCCIA DA**  
**SOSTITUIRE AD INTERVALLI**  
**REGOLARI - VEDI MANUALE**

**FILTER WITH CARTRIDGE**  
**TO BE REPLACED AT REGULAR**  
**INTERVALS – SEE MANUAL**

— 4

Oil level check info plate.  
Check lubricating oil level every 50 working hours and change it every 250 working hours.  
For information on how to check see “7.6.2 Checking the oil level”.  
For information on how to change the oil see “7.6.3 Changing the lubricating oil”.

**ATTENZIONE**  
**CONTROLLARE IL LIVELLO DELL'OLIO**  
**OGNI 50 ORE E SOSTITUIRLO OGNI**  
**250 ORE DI LAVORO**  
**WARNING**  
**CHECK OIL LEVEL EVERY 50 HOURS**  
**AND CHANGE OIL EVERY**  
**250 WORKING HOURS**



5

- a Hands at risk of being crushed in transmission belt zone
- b Moving parts in transmission belt and cooling zone fan
- c Live wires: risk of electric shock
- d Forbidden to remove covers/guards
- e Forbidden to lubricate mechanical parts when they are moving: compressor must be switched off before any maintenance/lubrifications tasks are carried out on it.
- f Safety gloves must be worn.
- g Safety goggles must be worn.
- h Hard hat must be worn.

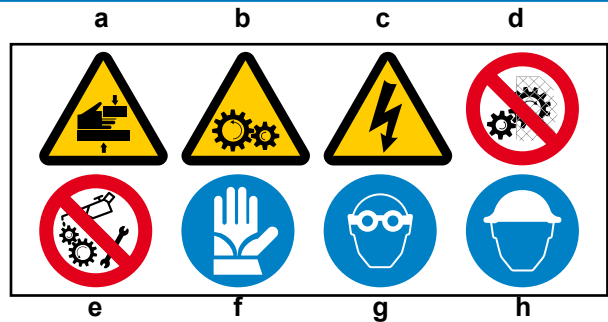

6

- a Warning info plates about the dangers that derive from a lack of knowledge about the compressor and its functions and the consequent risks.
- b Read the use and maintenance manual carefully before using the compressor.

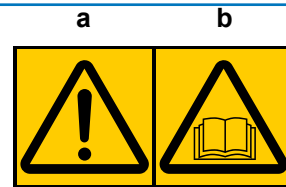

7

Maximum working pressure.



8

Live electrical circuit danger warning.



9

Condensate discharge info plate.  
Indicates position of condensate discharge valve.  
To discharge the condensate see "7.9 Condensate discharge".



**10**

Cooling fan direction of rotation info label.

When using the machine for the first time check that the fan rotates in the direction indicated by the arrow.



If, on a three-phase electric motor compressor, the fan rotates against the direction of the arrow invert two of the three phases on the main power lead.

**11**

Oil drain label.

Indicates the position of the lubricating oil drain taps.

To drain the oil see section "7.6.3 Changing the lubrication oil".

**SCARICO OLIO**

**OIL DRAIN**

**12**

Safety valve info plate

The safety valve is calibrated by the manufacturer to 225 bar, 300 bar or 330 bar.

To check the safety valve refer to "7.8 Checking the safety valve".

**VALVOLA DI SICUREZZA  
SAFETY VALVE  
225 BAR**

**VALVOLA DI SICUREZZA  
SAFETY VALVE  
300 BAR**

**VALVOLA DI SICUREZZA  
SAFETY VALVE  
330 BAR**

**IMPORTANT**

Should the safety valve fail to work properly contact the AEROTECNICA COLTRI technical assistance service.

## 3.4 GENERAL SAFETY REGULATIONS

### 3.4.1 Care and maintenance

Damage and accidents are often caused by maintenance errors, such as:

- no oil,
- insufficient cleaning,
- compressed air circuit inefficiency (flex hoses damaged, loose pipes, screws etc.).

Maintenance work must be carried out with due care and attention: your safety depends on it.

Never postpone repairs.

Repairs must only be carried out by specialised or authorised personnel.

Always observe the following safety regulations, even when you become completely familiar with working procedures:

- Keep the compressor and the surrounding area clean at all times.
- Before starting work check that safety devices/guards are in good working order.
- Make sure no-one is in the compressor danger zone. Interrupt work if anyone is in the danger zone and tell them to leave.
- Never leave the machine unattended when it is running.

### 3.4.2 Fire extinguishers and first aid

- Check that a fire extinguisher is present. Make sure all personnel know where it is.
- Periodically check that extinguishers are full and operators know how to use them.
- The location of the first aid cabinet must be known.
- Check the first aid cabinet periodically to make sure it contains disinfectant, bandages, medicines etc.
- Fire drills must be known.
- Make sure a phone number for emergency medical assistance is kept nearby.

#### IMPORTANT



The provision of a fire extinguisher is the responsibility of the owner of the compressor.

### 3.5 MAINTENANCE PRECAUTIONS

#### 3.5.1 Warning signs

Before doing any maintenance work, stop the engine/motor and make sure the compressed air system is depressurised.

If other people start the engine or act on the control pushbuttons/keys while maintenance work is in progress there is a risk of serious injury or death.

To avoid these dangers always place warning signs around the compressor before carrying out maintenance.



#### 3.5.2 Tools

Use only manufacturer-recommended tools; do not use worn, damaged, poor quality or improvised tools as they can cause injury.

#### WARNING



The manufacturer cannot be held liable for any damage or injury caused by the use of tools that are not prescribed or modified without authorisation.

#### 3.5.3 Personnel

The routine maintenance tasks described in this manual must only be carried out by trained, authorised personnel.

For component maintenance/revision tasks not covered by this manual please contact **AEROTECNICA COLTRI**.

#### 3.5.4 Keeping the compressor clean

Oil and grease stains, scattered tools or broken pieces constitute a danger to personnel as they may cause slips and falls. Always keep the compressor and the surrounding work area clean and tidy.

Clean the compressor with a pressurised hot water or steam jet and commercially available detergents. Do not use diesel, petrol or solvents as the former leave an oily film that causes dust to stick while solvents (even where weak) damage the paintwork and can lead to rust.

If the water jet gets inside the electrical parts it could, in addition to oxidising the contacts, prevent the machine being started or even cause a sudden, unexpected start.

For this reason never use water or steam jets on sensors or connectors.

#### 3.5.5 Periodic replacement of essential safety parts

Periodically check the following components, which are important for fire prevention:

- compressed air system: main compressed air circuit delivery hoses;
- bottle refill system: flex hoses for bottle refill.

Even though they may appear to be in good condition, these components must be periodically replaced with new ones. Over time these components tend to deteriorate.

Should any of these parts prove to be faulty, replace or repair them ahead of schedule.

## 4 - TECHNICAL DATA

### 4.1 TECHNICAL CHARACTERISTICS

#### 4.1.1 Crankcase, crankshaft, cylinders, pistons

The crankcase is made of aluminium alloy; the flanges with roller bearings on the filter sides and ball bearings on the fan side that support the crankshaft are kept oil-tight with the crankcase by O-rings between flange and crankcase and the oil retainer between flange and motor shaft.

The crankshaft and the connecting rods run on bearings with roller cages only. The connecting rods are fitted on the crankshaft with a single crank angle.

The cylinders are made of cast iron, the pistons are made of aluminium and feature traditional multiple piston rings. The high pressure stage piston has a special anti-wear lining. The relative cylinder is self-lubricating.

#### 4.1.2 Valves

The heads set features outlet and intake valves. The 1<sup>st</sup> stage head is reed valve type and includes both intake and pressure. The intake and pressure valves are inserted directly in the respective threaded seats of the 2<sup>nd</sup> and 3<sup>rd</sup> stage heads. (Pressure valve of 3<sup>rd</sup> stage have no threads).

#### 4.1.3 Safety valves

The safety valves are pre-adjusted during assembly of the compressor and prevent it being damaged in the event of a malfunction. The max pressure, as a function of the valve, as follows:

1 <sup>st</sup> stage safety valve	8 bar - (114 PSI)
2 <sup>nd</sup> stage safety valve	50 bar - (710 PSI)
3 <sup>rd</sup> stage safety or final valve	225 bar - (3200 PSI)
	300 bar - (4300 PSI)
	330 bar - (4700 PSI)

#### WARNING



It is strictly forbidden to carry out any adjustments to the valve to raise its factory preset pressure.

Tampering with the safety valve can cause serious damage and renders the warranty null and void.

#### 4.1.4 Pressure maintenance valve

This valve is fitted after the final filter. When the compressor is switched on it keeps internal system pressure at 100 ±20 bar so as to remove as much water as possible from the air.

#### 4.1.5 Lubrication

Splash lubrication occurs by oil thrower pins screwed onto the 2<sup>nd</sup> and 3<sup>rd</sup> stage connecting rods. Third stage lubrication is of the oil vapour type.

#### 4.1.6 Cooling tubes

The cooling pipes are made of stainless steel.

#### 4.1.7 Frame, guards

The compressor and motor are mounted on a welded steel frame that has been painted with epoxy resins. The frame consists of painted panelling with a handle for the purpose of moving it. Stainless steel frame available on request.

4.2 MACHINE PARTS

- 1 Frame
- 2 Control pannel
- 3 Condensate discharge pushbutton
- 4 ON pushbutton
- 5 Stop pushbutton
- 6 Emergency pushbutton
- 7 Hour counter
- 8 Motor
- 9 Compressor
- 10 3<sup>rd</sup> stage pressure gauge
- 11 Automatic shutdown pressure switch
- 12 Air filter
- 13 Final condensate separator
- 14 Active carbon air filter / molecular sieve
- 15 1<sup>st</sup> stage
- 16 2<sup>nd</sup> stage
- 17 3<sup>rd</sup> stage
- 18 Monobloc
- 19 Oil filler plug
- 20 Safety valve
- 21 Maintenance valve
- 22 Cooling fan
- 23 Belt
- 24 Anti-vibration device
- 25 Condensate discharge valves
- 26 Condensate collection can
- 27 Oil drain plug
- 28 Oil level
- 29 Refill hoses connection
- 30 Intake extension hole

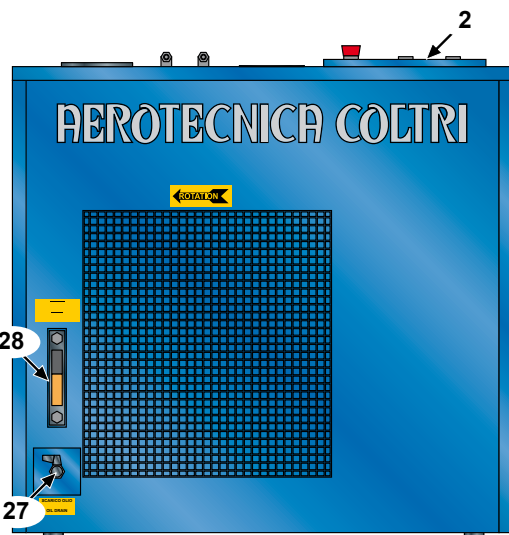
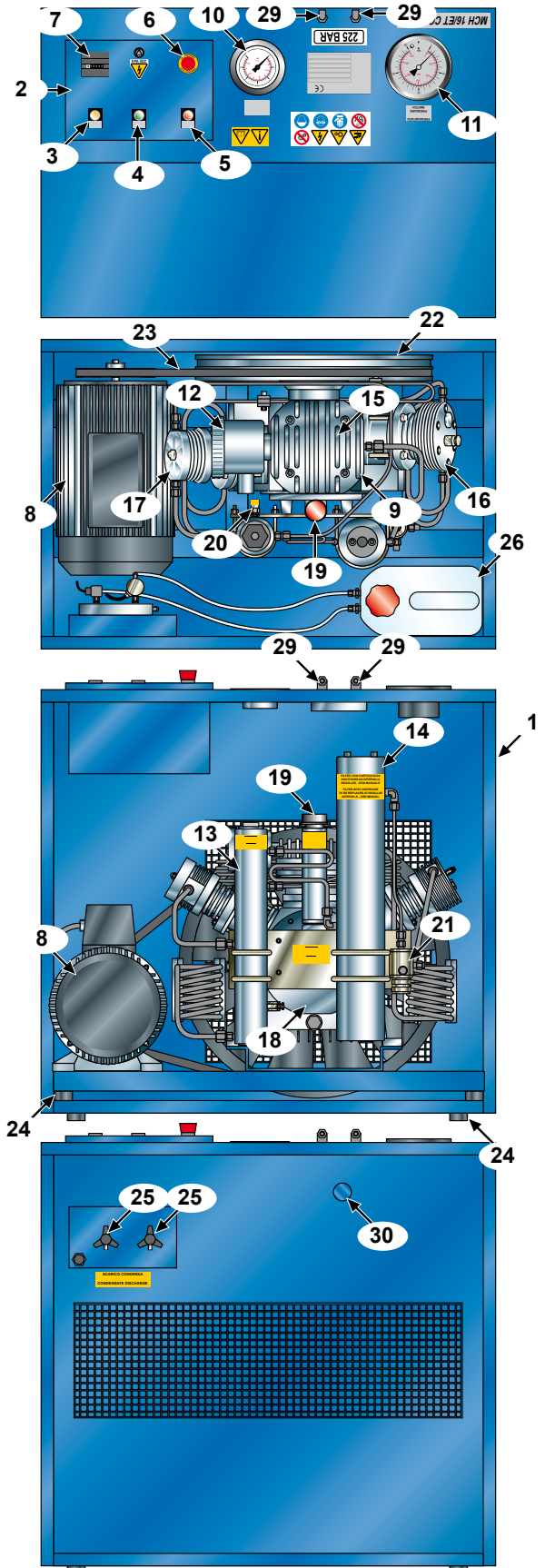

**4.3 TECHNICAL CHARACTERISTICS**

**4.3.1 MCH 8-11/EM Compact**

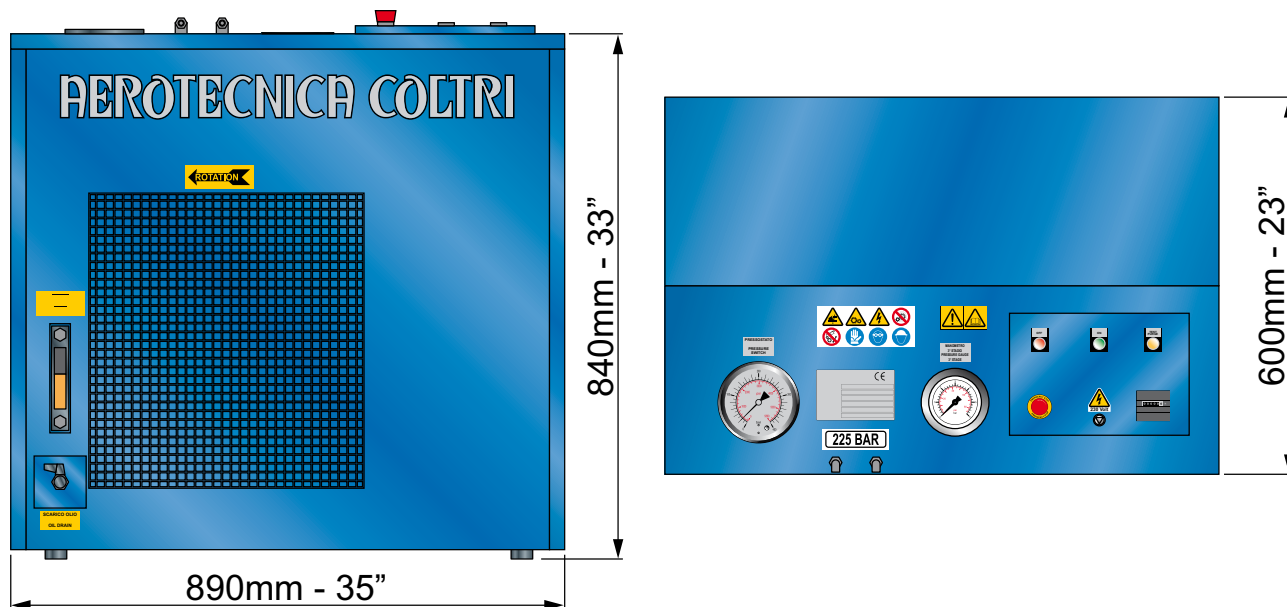

		<b>MCH-8</b>		<b>MCH-11</b>	
		<b>Single-phase electric</b>		<b>Single-phase electric</b>	
Engine					
Engine power	(kW)	<b>3</b>		<b>4</b>	
	(HP)	<b>4</b>		<b>5,4</b>	
Engine rpm	(rpm)	<b>2800</b>	<b>3400</b>	<b>2800</b>	<b>3400</b>
Voltage	(V)	<b>230</b>	<b>230</b>	<b>230</b>	<b>230</b>
Frequency	(Hz)	<b>50</b>	<b>60</b>	<b>50</b>	<b>60</b>
Absorption	(A)	<b>18</b>	<b>16</b>	<b>24</b>	<b>22</b>
Pumpin Unit	(rpm)	<b>900</b>		<b>1200</b>	
Pressure 1 <sup>st</sup> stage	(bar/PSI)	<b>5 / 73</b>		<b>5 / 73</b>	
Pressure 2 <sup>nd</sup> stage	(bar/PSI)	<b>40 / 580</b>		<b>40 / 580</b>	
Working pressure	(bar)	<b>225-300-330</b>		<b>225-300-330</b>	
	(PSI)	<b>3200-4300-4700</b>		<b>3200-4300-4700</b>	
Delivery rate	(l/min)	<b>135</b>		<b>195</b>	
	m <sup>3</sup> /h	<b>8</b>		<b>11</b>	
	CFM	<b>5</b>		<b>7</b>	
Refill time 10l	(min)	<b>15</b>		<b>11</b>	
Noise level (ISO 3746)	(dB)	<b>78</b>		<b>78</b>	
Dry weight	(Kg)	<b>99</b>		<b>99</b>	
	(lb)	<b>218,2</b>		<b>218,2</b>	
Dimensions	(mm)	<b>840x890x600</b>		<b>840x890x600</b>	
	(inches)	<b>33x35x23</b>		<b>33x35x23</b>	

**4.3.2 MCH 13-16/ET Compact**

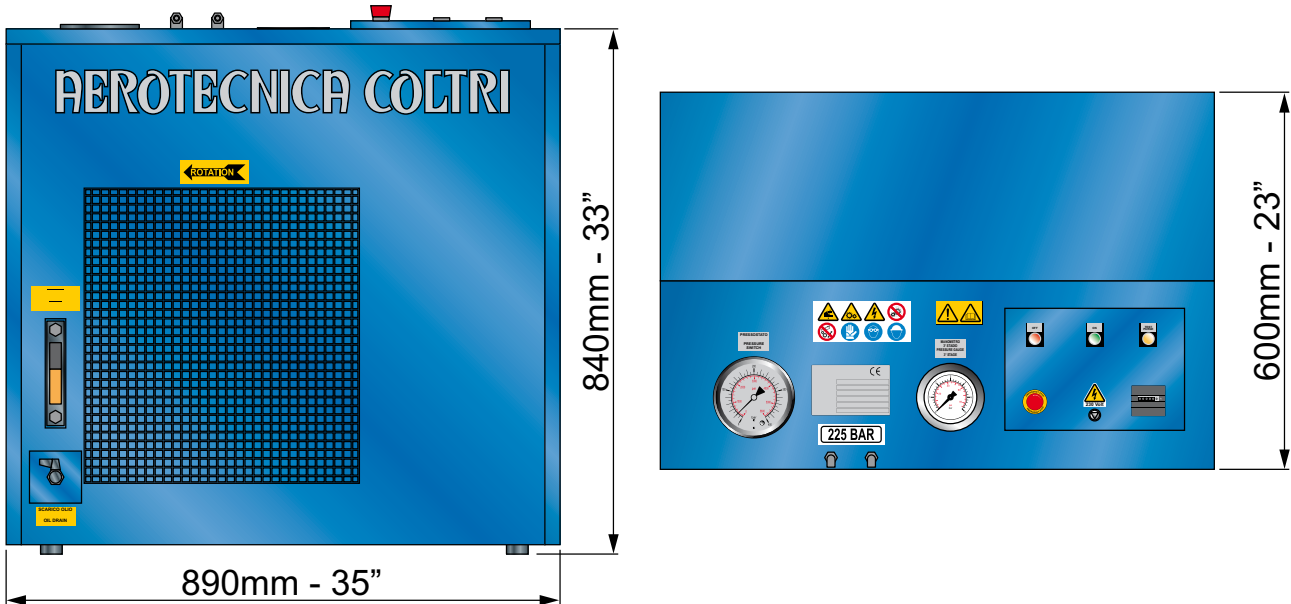

	<b>MCH-13</b>			<b>MCH-16</b>		
	<b>Three-phase electric</b>			<b>Three-phase electric</b>		
Engine						
Engine power (kW)	<b>4</b>	<b>4,8</b>		<b>5,5</b>	<b>6,6</b>	
(HP)	<b>5,5</b>	<b>6,5</b>		<b>7,5</b>	<b>8,9</b>	
Engine rpm (rpm)	<b>2840</b>	<b>3410</b>		<b>2850</b>	<b>3420</b>	
Voltage (V)	<b>230-400</b>	<b>230-400</b>	<b>440-480</b>	<b>230-400</b>	<b>230-400</b>	<b>440-480</b>
Frequency (Hz)	<b>50</b>	<b>60</b>	<b>60</b>	<b>50</b>	<b>60</b>	<b>60</b>
Absorption (A)	<b>15/8,7</b>	<b>15/8,7</b>	<b>8,7</b>	<b>20/11,6</b>	<b>20/11,6</b>	<b>11,6</b>
Pumpin Unit (rpm)	<b>1350</b>			<b>1550</b>		
Pressure 1 <sup>st</sup> stage (bar/PSI)	<b>5 / 73</b>			<b>5 / 73</b>		
Pressure 2 <sup>nd</sup> stage (bar/PSI)	<b>40 / 580</b>			<b>40 / 580</b>		
Working pressure (bar)	<b>225-300-330</b>			<b>225-300-330</b>		
(PSI)	<b>3200-4300-4700</b>			<b>3200-4300-4700</b>		
Delivery rate (l/min)	<b>215</b>			<b>265</b>		
m <sup>3</sup> /h	<b>13</b>			<b>16</b>		
CFM	<b>7,5</b>			<b>9</b>		
Refill time 10l (min)	<b>9</b>			<b>8</b>		
Noise level (ISO 3746) (dB)	<b>79,4</b>			<b>81</b>		
Dry weight (Kg)	<b>141</b>			<b>151</b>		
(lb)	<b>311</b>			<b>333</b>		
Dimensions (mm)	<b>840x890x600</b>			<b>840x890x600</b>		
(inches)	<b>33x35x23</b>			<b>33x35x23</b>		



**4.3.3 MCH 26-32/ET Compact**

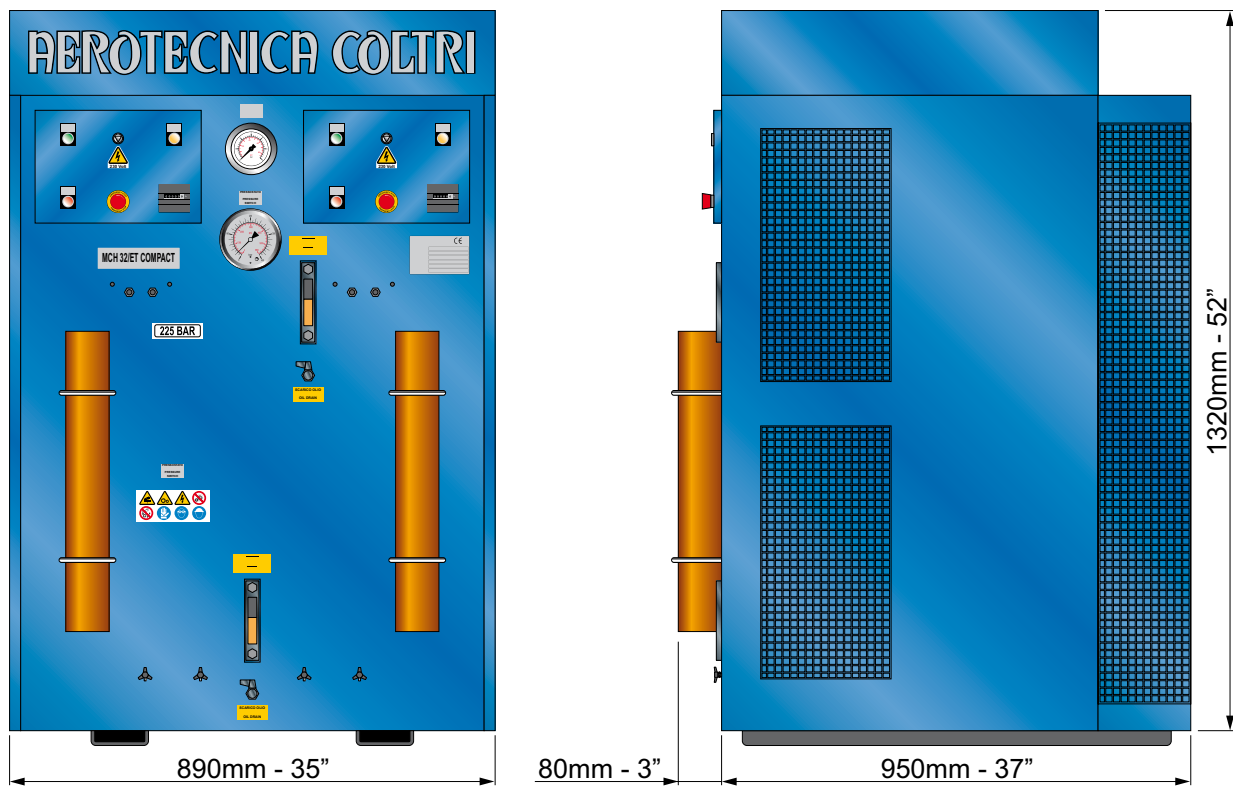

	<b>MCH-26</b>			<b>MCH-32</b>		
	<b>Three-phase electric</b>			<b>Three-phase electric</b>		
Engine						
Engine power (kW)	<b>2 x 4</b>	<b>2 x 4,8</b>		<b>2 x 5,5</b>	<b>2 x 6,6</b>	
(HP)	<b>2 x 5,5</b>	<b>2 x 6,5</b>		<b>2 x 7,5</b>	<b>2 x 8,9</b>	
Engine rpm (rpm)	<b>2 x 2840</b>	<b>2 x 3410</b>		<b>2 x 2850</b>	<b>2 x 3420</b>	
Voltage (V)	<b>230-400</b>	<b>230-400</b>	<b>440-480</b>	<b>230-400</b>	<b>230-400</b>	<b>440-480</b>
Frequency (Hz)	<b>50</b>	<b>60</b>	<b>60</b>	<b>50</b>	<b>60</b>	<b>60</b>
Absorption (A)	<b>2 x 15/8,7</b>	<b>2 x 15/8,7</b>	<b>2 x 8,7</b>	<b>2 x 20/11,6</b>	<b>2 x 20/11,6</b>	<b>2 x 11,6</b>
Pumpin Unit (rpm)	<b>1350</b>			<b>1550</b>		
Pressure 1 <sup>st</sup> stage (bar/PSI)	<b>5 / 73</b>			<b>5 / 73</b>		
Pressure 2 <sup>nd</sup> stage (bar/PSI)	<b>40 / 580</b>			<b>40 / 580</b>		
Working pressure (bar)	<b>225-300-330</b>			<b>225-300-330</b>		
(PSI)	<b>3200-4300-4700</b>			<b>3200-4300-4700</b>		
Delivery rate (l/min)	<b>430</b>			<b>530</b>		
m <sup>3</sup> /h	<b>26</b>			<b>32</b>		
CFM	<b>15</b>			<b>18</b>		
Refill time 10l (min)	<b>5</b>			<b>4</b>		
Noise level (ISO 3746) (dB)	<b>72,4</b>			<b>75</b>		
Dry weight (Kg)	<b>286</b>			<b>306</b>		
(lb)	<b>630</b>			<b>674</b>		
Dimensions (mm)	<b>1320x890x860</b>			<b>1320x890x860</b>		
(inches)	<b>52x35x33</b>			<b>52x35x33</b>		

**4.3.4 MCH 13-16-18/ET Compact Evo**

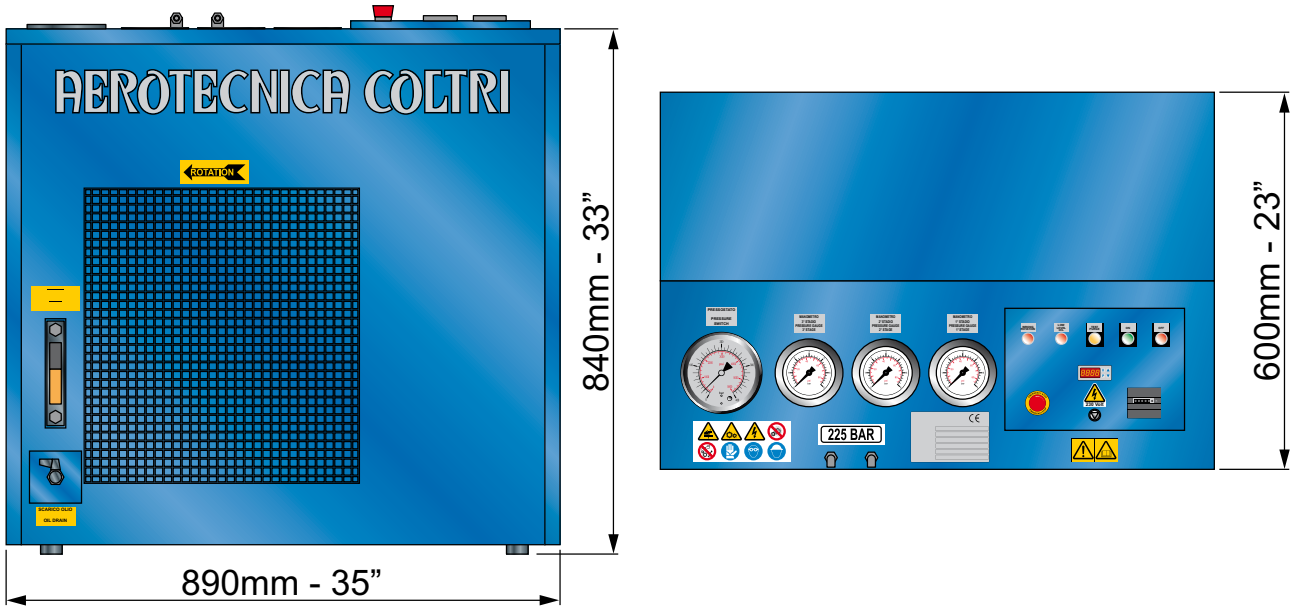

	<b>MCH-13</b>			<b>MCH-16</b>			<b>MCH-18</b>		
	<b>Three-phase electric</b>			<b>Three-phase electric</b>			<b>Three-phase electric</b>		
Engine									
Engine power (kW)	<b>4</b>	<b>4,8</b>		<b>5,5</b>	<b>6,6</b>		<b>7,5</b>	<b>7,5</b>	
(Hp)	<b>5,5</b>	<b>6,5</b>		<b>7,5</b>	<b>8,9</b>		<b>10</b>	<b>10</b>	
Engine rpm (rpm)	<b>2840</b>	<b>3410</b>		<b>2850</b>	<b>3420</b>		<b>2850</b>	<b>3420</b>	
Voltage (V)	<b>230-400</b>	<b>230-400</b>	<b>440-480</b>	<b>230-400</b>	<b>230-400</b>	<b>440-480</b>	<b>230-400</b>	<b>230-400</b>	<b>440-480</b>
Frequency (Hz)	<b>50</b>	<b>60</b>	<b>60</b>	<b>50</b>	<b>60</b>	<b>60</b>	<b>50</b>	<b>60</b>	<b>60</b>
Absorption (A)	<b>15/8,7</b>	<b>15/8,7</b>	<b>8,7</b>	<b>20/11,6</b>	<b>20/11,6</b>	<b>11,6</b>	<b>20/11,6</b>	<b>20/11,6</b>	<b>11,6</b>
Pumpin Unit (rpm)	<b>1350</b>			<b>1550</b>			<b>1800</b>		
Pressure 1 <sup>st</sup> stage (bar/PSI)	<b>5 / 73</b>			<b>5 / 73</b>			<b>5 / 73</b>		
Pressure 2 <sup>nd</sup> stage (bar/PSI)	<b>40 / 580</b>			<b>40 / 580</b>			<b>40 / 580</b>		
Working pressure (bar)	<b>225-300-330</b>			<b>225-300-330</b>			<b>225-300-330</b>		
(PSI)	<b>3200-4300-4700</b>			<b>3200-4300-4700</b>			<b>3200-4300-4700</b>		
Delivery rate (l/min)	<b>215</b>			<b>265</b>			<b>300</b>		
m <sup>3</sup> /h	<b>13</b>			<b>16</b>			<b>18</b>		
CFM	<b>7,5</b>			<b>9</b>			<b>10,5</b>		
Refill time 10l (min)	<b>9</b>			<b>8</b>			<b>7</b>		
Noise level (ISO 3746) (dB)	<b>66,2</b>			<b>68,8</b>			<b>69,8</b>		
Dry weight (Kg)	<b>212</b>			<b>222</b>			<b>230</b>		
(lb)	<b>468</b>			<b>490</b>			<b>507</b>		
Dimensions (mm)	<b>840x890x600</b>			<b>840x890x600</b>			<b>840x890x600</b>		
(inches)	<b>33x35x23</b>			<b>33x35x23</b>			<b>33x35x23</b>		

**4.3.5 MCH 13-16/ET Compact M**

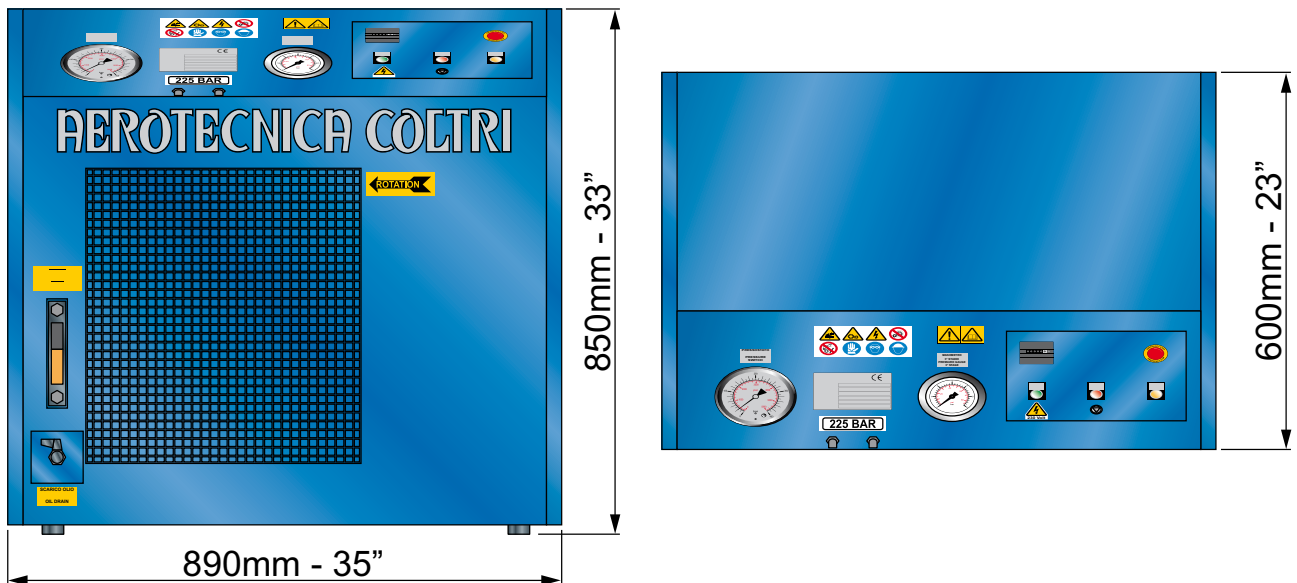

	<b>MCH-13</b>			<b>MCH-16</b>		
	<b>Three-phase electric</b>			<b>Three-phase electric</b>		
Engine						
Engine power	(kW)	<b>4</b>	<b>4,8</b>	<b>5,5</b>	<b>6,6</b>	
	(HP)	<b>5,5</b>	<b>6,5</b>	<b>7,5</b>	<b>8,9</b>	
Engine rpm	(rpm)	<b>2840</b>	<b>3410</b>	<b>2850</b>	<b>3420</b>	
Voltage	(V)	<b>230-400</b>	<b>230-400</b>	<b>440-480</b>	<b>230-400</b>	<b>230-400</b>
Frequency	(Hz)	<b>50</b>	<b>60</b>	<b>60</b>	<b>50</b>	<b>60</b>
Absorption	(A)	<b>15/8,7</b>	<b>15/8,7</b>	<b>8,7</b>	<b>20/11,6</b>	<b>20/11,6</b>
Pumpin Unit	(rpm)	<b>1350</b>			<b>1550</b>	
Pressure 1 <sup>st</sup> stage	(bar/PSI)	<b>5 / 73</b>			<b>5 / 73</b>	
Pressure 2 <sup>nd</sup> stage	(bar/PSI)	<b>40 / 580</b>			<b>40 / 580</b>	
Working pressure	(bar)	<b>225-300-330</b>			<b>225-300-330</b>	
	(PSI)	<b>3200-4300-4700</b>			<b>3200-4300-4700</b>	
Delivery rate	(l/min)	<b>215</b>			<b>265</b>	
	m <sup>3</sup> /h	<b>13</b>			<b>16</b>	
	CFM	<b>7,5</b>			<b>9</b>	
Refill time 10l	(min)	<b>9</b>			<b>8</b>	
Noise level (ISO 3746)	(dB)	<b>79,4</b>			<b>81</b>	
Dry weight	(Kg)	<b>141</b>			<b>151</b>	
	(lb)	<b>311</b>			<b>333</b>	
Dimensions	(mm)	<b>850x890x600</b>			<b>850x890x600</b>	
	(inches)	<b>33x35x23</b>			<b>33x35x23</b>	

**4.3.6 MCH 16/EM Compact E1**

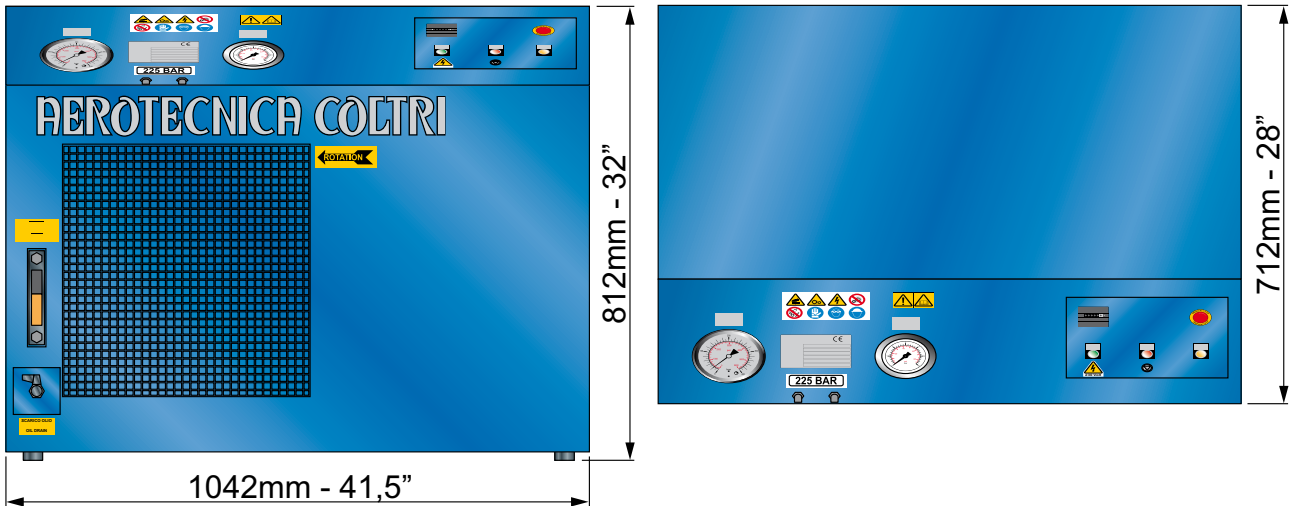

		<b>MCH-16</b>	
		<b>Single-phase electric</b>	
Engine			
Engine power	(kW)	<b>5,5</b>	
	(HP)	<b>7,5</b>	
Engine rpm	(rpm)	<b>2800</b>	<b>3400</b>
Voltage	(V)	<b>230</b>	<b>230</b>
Frequency	(Hz)	<b>50</b>	<b>60</b>
Absorption	(A)	<b>34</b>	<b>34</b>
Pumpin Unit	(rpm)	<b>1550</b>	
Pressure 1 <sup>st</sup> stage	(bar/PSI)	<b>5 / 73</b>	
Pressure 2 <sup>nd</sup> stage	(bar/PSI)	<b>40 / 580</b>	
Working pressure	(bar)	<b>225-300-330</b>	
	(PSI)	<b>3200-4300-4700</b>	
Delivery rate	(l/min)	<b>265</b>	
	m <sup>3</sup> /h	<b>16</b>	
	CFM	<b>9</b>	
Refill time 10l	(min)	<b>8</b>	
Noise level (ISO 3746)	(dB)	<b>81</b>	
Dry weight	(Kg)	<b>194</b>	
	(lb)	<b>425</b>	
Dimensions	(mm)	<b>812x1042x712</b>	
	(inches)	<b>32x41,5x28</b>	

4.4 PRESSURE CIRCUIT

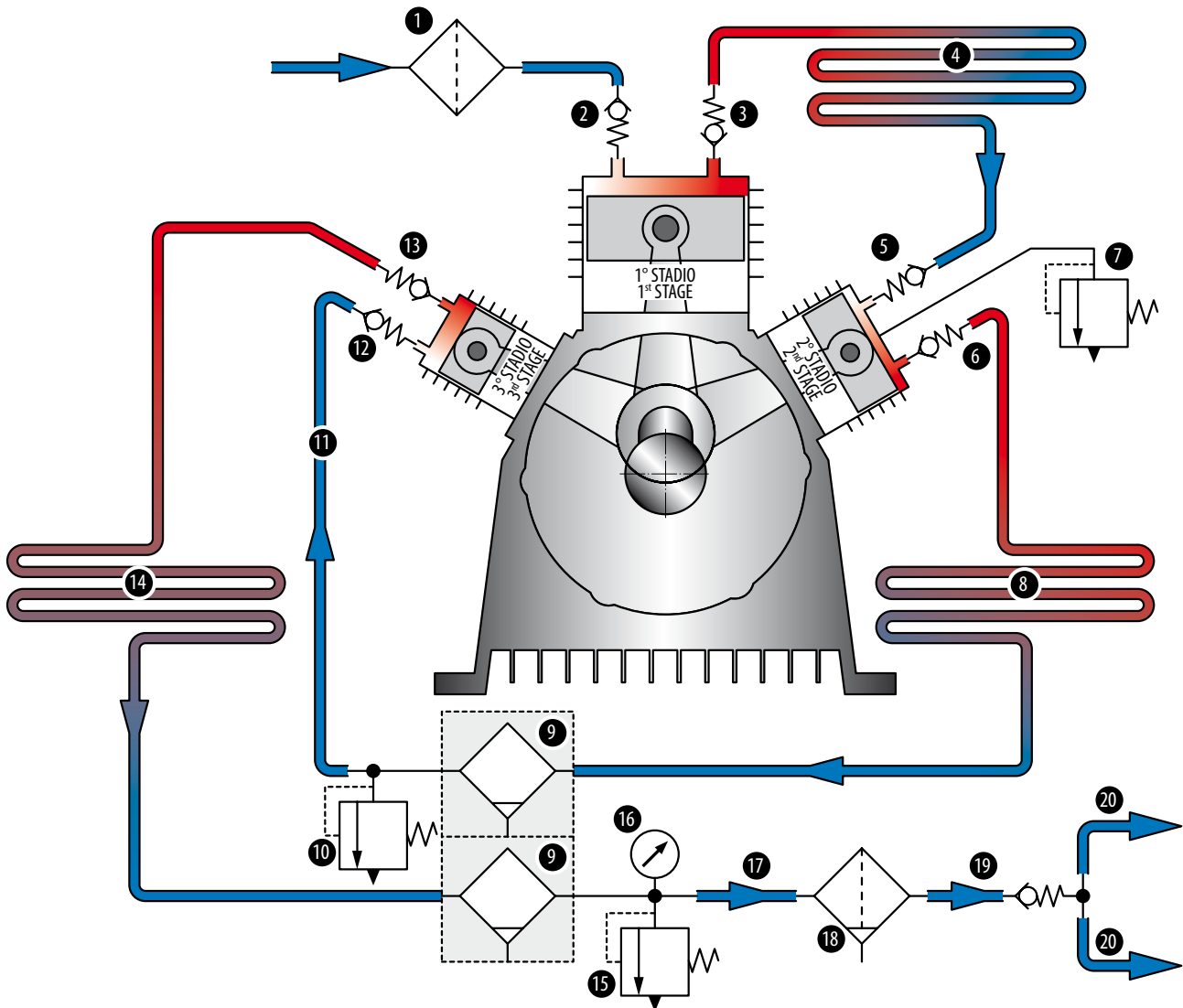

- |                              |   |
|------------------------------|---|
| 1 Intake filter              | 11 Pipe separator/3rd stage                 |
| 2 Intake valve 1st stage     | 12 Intake valve 3rd stage                   |
| 3 Outlet valve 1st stage     | 13 Outlet valve 3rd stage                   |
| 4 Cooling pipe 1st-2nd stage | 14 Final cooling pipe                       |
| 5 Intake valve 2nd stage     | 15 Safety valve                             |
| 6 Outlet valve 2nd stage     | 16 Pressure gauge                           |
| 7 Safety valve 1st stage     | 17 Pipe separator/filter                    |
| 8 Cooling pipe 2nd-3rd stage | 18 Active carbon air filter/molecular sieve |
| 9 Condensate separator       | 19 Pressure maintenance valve               |
| 10 Safety valve 2nd stage    | 20 Flex hoses                               |

## 5 - HANDLING AND INSTALLATION

### 5.1 UNPACKING

**Compact** series compressors are sent fully assembled, with the flex hoses separate.

The compressor is packed in a cardboard box on a pallet to simplify handling and transport.

The box containing the compressor must be moved according to the instructions shown on the box itself.

The machine is supplied with the following as standard:

- two 1200 mm refill hoses with filling valves
- use and maintenance manual
- use and maintenance manual appendix (safety regulations)
- lubricating oil (2 litres)
- active carbon and molecular sieve filter cartridge.

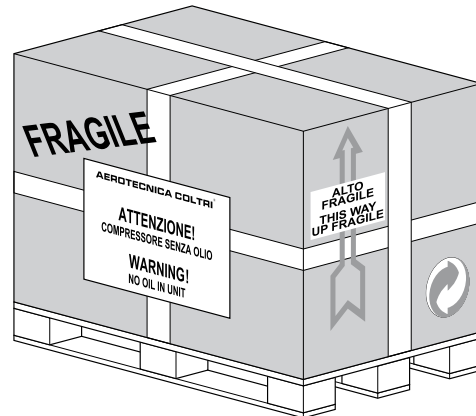

### 5.2 HANDLING

After separating the compressor from its packaging it can be transported to the designated placement area. Transfer will require the use of a fork-lift or transpallet (of suitable load-bearing capacity): the forks must be positioned in the support feet on which the europallet is positioned.

#### IMPORTANT

Proceeding with the utmost care when lifting, transferring and positioning the compressor.



### 5.3 INSTALLATION

#### WARNING

Before proceeding with the installation tasks described below, read Chapter 3 "SAFETY REGULATIONS" carefully.



#### 5.3.1 Positioning

- Position the compressor in the designated area and check it is level. For compressor dimensions please consult section 4.3 "Technical characteristics".
- Check that the area in which the compressor is to be positioned is adequately ventilated: good air exchange (more than one window), no dust and no risk of explosion, corrosion or fire.
- If ambient temperatures exceed 45°C air conditioning will be necessary.
- Position the compressor no closer than 1 m to surrounding walls; the gap between compressor and ceiling should be at least 1.5 m. These distances ensure proper compressor operation and proper cooling of the pumping unit.
- Make sure that lighting in the area is sufficient to identify every detail (such as the writing on the info labels); use artificial lighting where daylight is on its own insufficient.

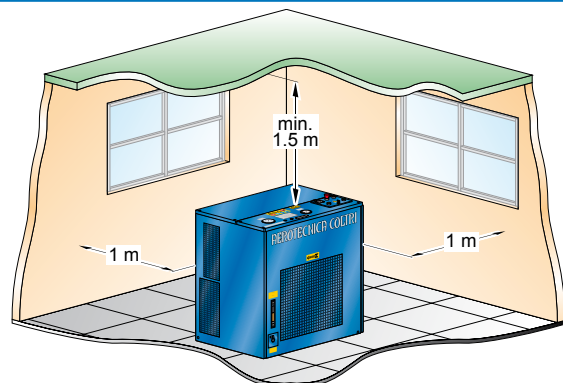

### 5.3.2 Air intake extension connection

If the compressor is installed in an area without the necessary ventilation requisites described in section 5.3.1 "Positioning", it will be necessary to install an air intake extension leading in from outdoors or a place with the cited ventilation requisites.

- The extension, supplied as an optional, must be connected to the intake connector (a).
- Connect extension pipe to fitting.
- Pass the pipe through the hole on the side panel (b).
- Fit the supplementary intake filter on the extremity of the extension pipe.
- Position the end of the extension with the air intake filter in a properly ventilated area sheltered from weather and exhaust fumes.
- Point the air intake against the wind.
- Check that there are no kinks or breaks along the pipe. If it is damaged replace it.

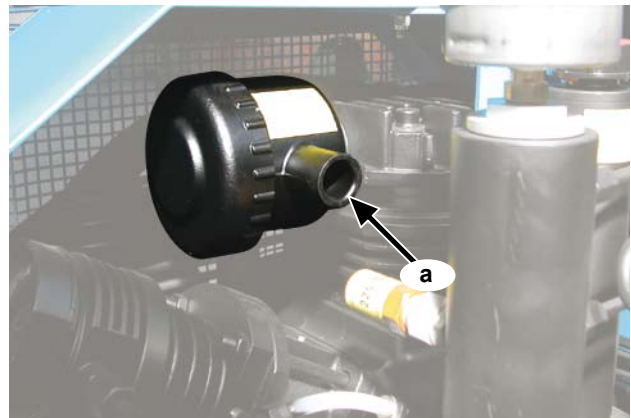

#### WARNING



Use only a flexible pipe with internal steel braiding reinforcement so as to prevent kinks and a consequent reduction of cross-section.  
Do not aspirate harmful gases or exhaust fumes.



### 5.3.3 Electrical connection

The compressor is supplied with an electrical lead and, depending on the model, with a plug (see diagram at right).

To connect up to the power supply just insert the plug in the mains power socket.

Check that the data on the compressor ID plate is compatible with mains power supply, especially as regards rated current and voltage.

The mains power system must have an efficient ground (earth); check that the earth resistance value complies with the protection / operational requirements of the compressor electrical system.

**Model: MCH-8/EM**  
**Schuko plug supplied**

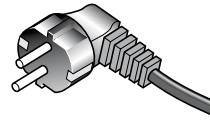

**Modello: MCH-11/EM**  
**32A 2P+E plug not supplied**

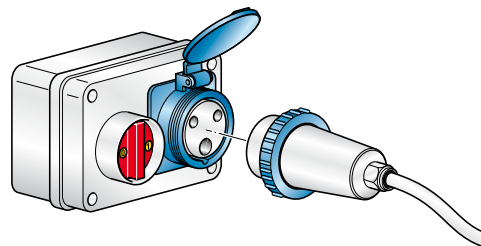

**Model: MCH-13/ET**  
**16A 3P+E plug not supplied**

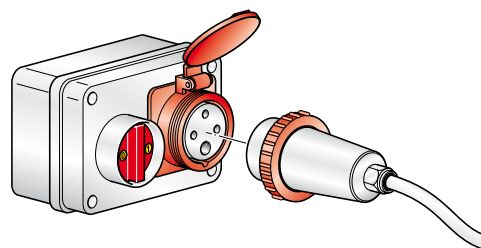

**Model: MCH-16/ET - MCH26-32/ET**  
**32A 3P+E plug not supplied**

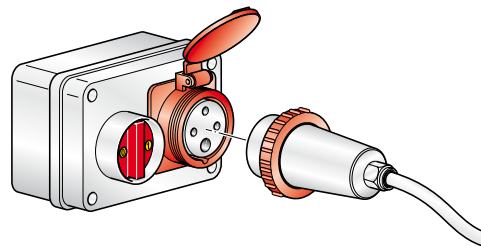

#### WARNING



Before inserting the plug, check that the electrical system complies with the standards in force in the country of installation. A proper earth (ground) system is an essential safety requisite.

An efficient compressor ground (earth) system is an essential compressor safety requisite.

The mains power connection plug must be type-approved in compliance with the relevant standards and have an ON-OFF switch (not supplied).



## 6 - USING THE COMPRESSOR

### 6.1 PRELIMINARY CHECKS BEFORE USING FOR THE FIRST TIME

The operator must check that the compressor is supplied with:

- use and maintenance manual;
- the appendix to the use and maintenance manual (where applicable);

If the compressor is sold on the customer/user must provide the purchaser with a complete, undamaged use and maintenance manual.

#### 6.1.1 Filling with lubricating oil

At the time of delivery the compressor does not contain lubricating oil; this is supplied together with the compressor in cans contained in the packaging.

For filling instructions see section "7.6.3 Changing the lubricating oil".

#### 6.1.2 Checking for proper electrical connection

Check for proper connection of electrical phases by checking that the cooling fan rotates in the direction indicated on the label (a) on the fan cover.

If the direction of rotation is not as indicated by the arrow it will be necessary to disconnect the electrical power supply and invert two of the three phases on the main power lead.



### DANGER

Before carrying out this task disconnect the compressor from the mains power supply.



Do not invert or disconnect the ground (earth) wire (yellow/green).

### 6.2 CHECKS TO BE RUN AT THE START OF EACH WORKING DAY

Inspect the exterior of the compressor (couplings, pipes, pneumatic components etc.) and check for any oil leaks. Replace parts where necessary or contact **AEROTECNICA COLTRI**.

#### 6.2.1 Lubricating oil level check

Check that the lubricating oil level (a) is within acceptable limits.

Note that an excessive quantity of oil can cause infiltrations in the cylinders and leave deposits on the valves while too low a level prevents proper lubrication and could cause engine seizure.

If the oil level is not within the minimum and maximum limits top up or drain as described in section "7.6.3 Changing the lubricating oil".

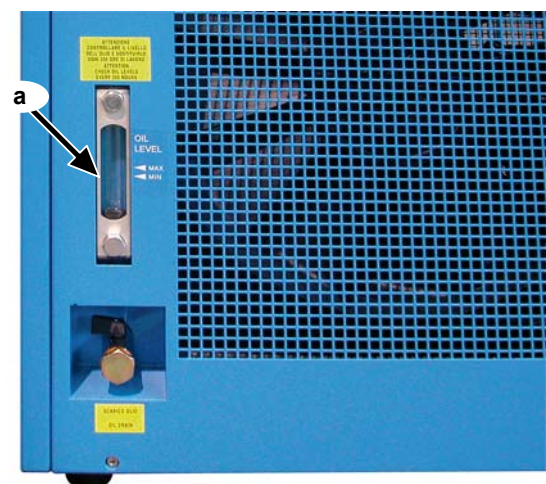

### 6.2.2 Checking that the refill flex hoses are in good condition

Inspect the refill hoses and make sure there are no cuts, holes, abrasions, leaks etc. If necessary replace with new hoses.

### 6.2.3 Storing technical documentation

The use and maintenance manual and its appendices must be stored carefully and must always be kept where they can be accessed easily for immediate consultation.

#### WARNING



The use and maintenance manual is an integral part of the compressor and must always be handed over in the event of a change of ownership.

## 6.3 PRELIMINARY TASKS

### 6.3.1 Checking the safety valves

Check that safety valves are working properly: start the compressor with the final taps closed and the pressure switch cursor at the maximum end of the scale so that circuit pressure rises rapidly and the valves trip at the set pressure.

The safety valve are pre-adjusted to 225 bar (3200 PSI), 300 (4300 PSI) and 330 bar (4700 PSI).

Check that the bottles to be refilled are in good condition: they must have been tested by the relevant authorities (stamped and/or certified). Run a visual check on the exterior.

Check that the refill hose and relevant fitting are in good condition.

After being refilled do not empty the bottles completely, not even during winter storage or long periods of inactivity: this will stop humidity getting in.

#### IMPORTANT



Tampering with the safety valve to increase the pressure setting is strictly forbidden. Tampering with the safety valve can seriously damage the compressor, cause serious injury to personnel and renders the warranty null and void.

#### DANGER



Should bottles show evident signs of internal/external corrosion, do not refill them even if they have been tested.

#### WARNING



Use only tested bottles (as proven by a test stamp and/or certificate). The working and bottle refill pressures are shown on the bottles themselves. It is forbidden to refill them at a pressure greater than that indicated.

#### IMPORTANT



Should the safety valve fail to work properly contact the AEROTECNICA COLTRI assistance service.

6.4 CONTROL PANEL

**WARNING**

It is forbidden to alter pressure parameters without authorisation from AEROTECNICA COLTRI.



Any unauthorised modifications shall render the warranty null and void.

COMPACT EVO control panel

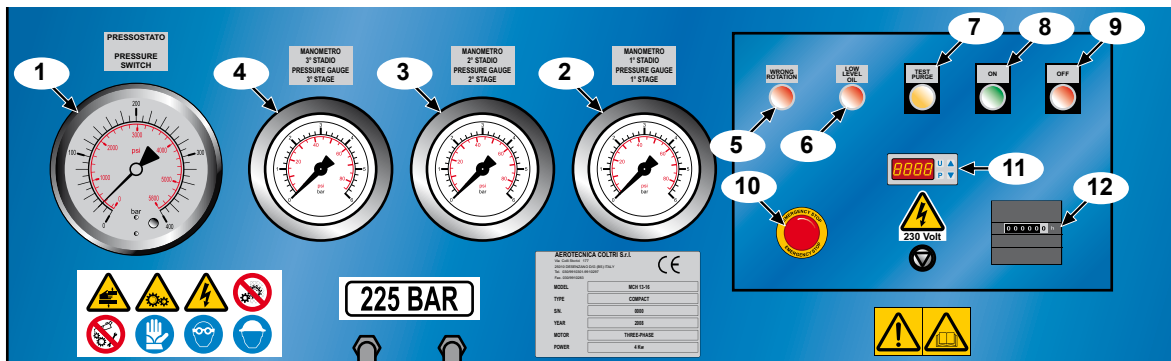

COMPACT control panel

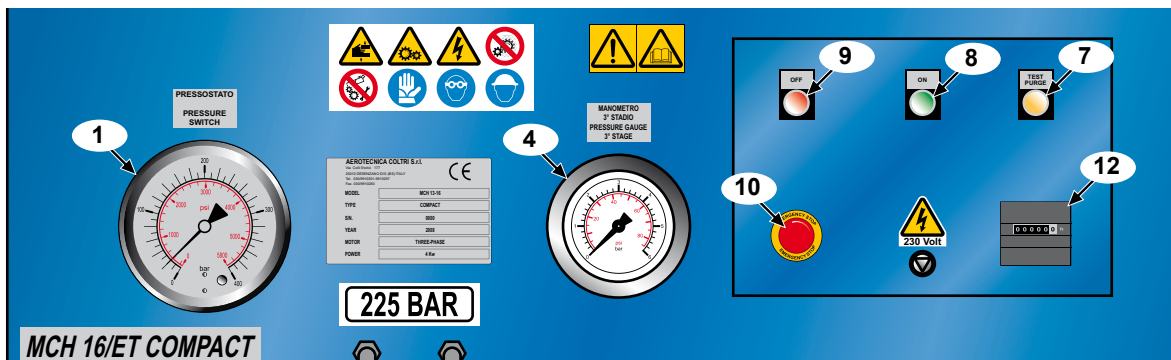

1 Automatic shutdown pressure switch

The automatic shutdown pressure switch (1) determines the compressor shutdown pressure. The shutdown pressure can be set via the regulator compressor reaches the set pressure it shuts down automatically.

The compressor can reach a maximum pressure of 225-300-330 bar (3200-4300-4700 PSI).

2 1<sup>st</sup> stage pressure gauge

Indicates the pressure inside the 1<sup>st</sup> compression stage.

3 2<sup>nd</sup> stage pressure gauge

Indicates the pressure inside the 2<sup>nd</sup> compression stage.

4 3<sup>rd</sup> stage pressure gauge

Indicates 3<sup>rd</sup> compression stage pressure and final refill pressure.

5 Direction of rotation warning light

If the light (5) comes on this means that the direction of compressor rotation is incorrect. To restore correct rotation see section "6.1.2 Checking electrical phase connections".

6 Oil level warning light

If the light (6) comes on this means that the oil level is too low; to restore the oil level see section "7.6.3 Changing lubricating oil".

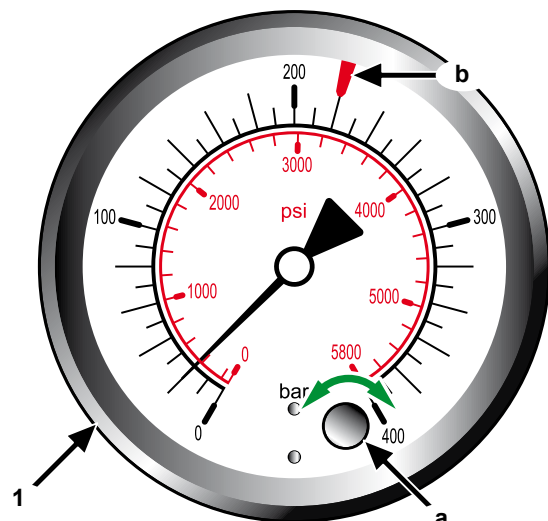

## COMPACT EVO control panel

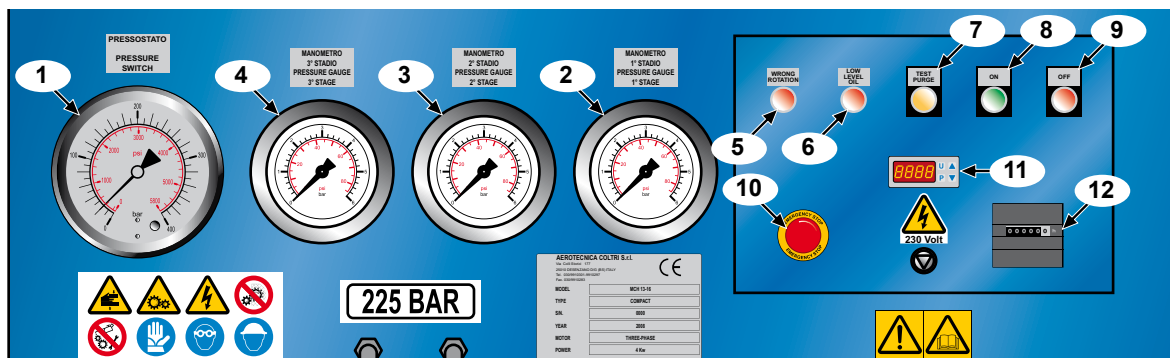

## COMPACT control panel

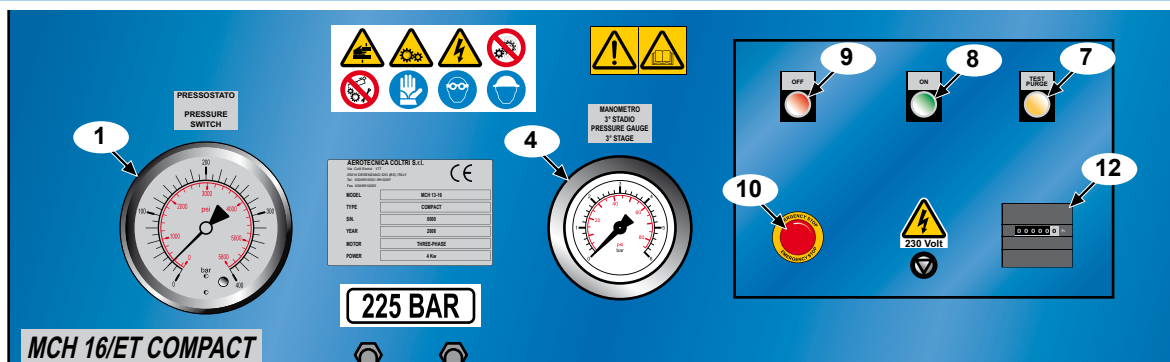
**7 Manual condensate discharge button**

Pressing the yellow manual condensate discharge button (7) drains the condensate collected in the special recipient during use of the compressor (no further tasks required: drainage interval managed with the pressure switch timer). To drain the condensate see section "7.9 Condensate discharge".

**8 ON pushbutton**

To start the compressor press the green ON pushbutton (8). The compressor will then run until the pressure that has been set on the adjustable pressure switch (1) is reached or until the safety valve release over pressure.

**9 OFF pushbutton**

Press the red OFF pushbutton (9) to stop the compressor.

**10 Pulsante emergenza**

In an emergency situation stop the compressor by pressing the red emergency pushbutton (10). Check that the emergency shutdown pushbutton is working properly at the start of each working day by switching on the compressor and pressing it. If the compressor fails to shut down immediately after pressing the emergency pushbutton disconnect the compressor from the power supply and contact **AEROTECNICA COLTRI**.

**11 Thermostat**

The thermostat (11) indicates the temperature inside the compressor. If the temperature is higher or lower than the parameters set on the thermostat the compressor shuts down and can only be restarted once temperature has returned within the permitted range.

**12 Hour counter**

The hour counter (12) indicates the number of working hours of the compressor: this provides a time reference for scheduled maintenance.

**6.5 STARTING AND SHUTTING DOWN**

**IMPORTANT**

These tasks must be carried out by qualified personnel who have been trained to use the compressor.



Before starting the engine open the condensate discharge points (a) to prevent a “strained” start (only MCH 8/11 model).

- check the voltage and that there is a proper earth contact.
- press the start pushbutton (b);
- for models with three-phase electric motor check th at the direction of rotation of the electric motor is as indicated by the arrow (e) on the cover (if it is not refer to “6.1.2 Checking for proper electrical connection”);
- close the condensate discharge points. (a) (only MCH 8/11 model);
- to switch off the compressor press the pushbutton (c).

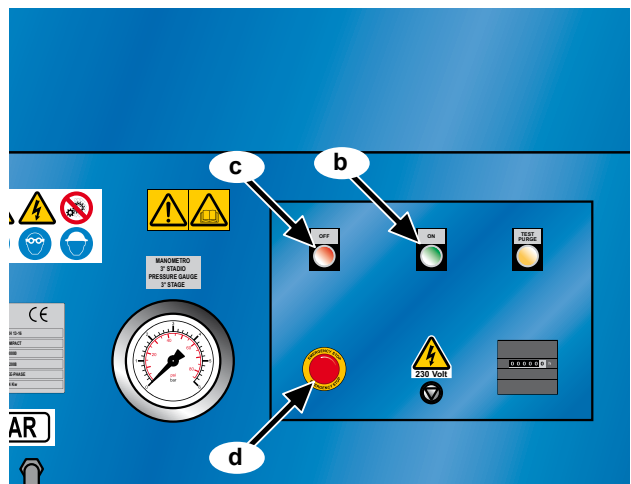
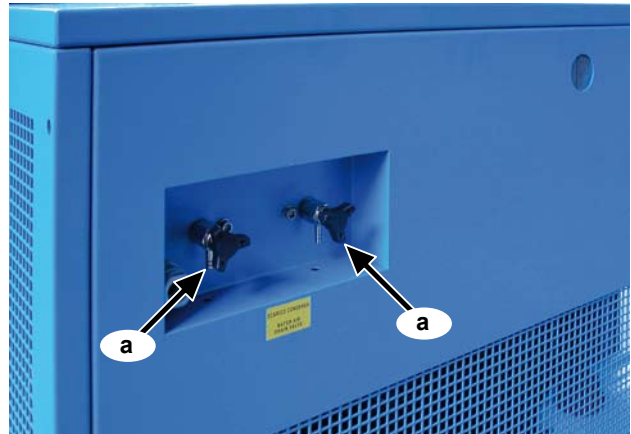

**WARNING**



If emergency or danger situations occur press the emergency pushbutton (d). To restore normal compressor operation rotate the emergency pushbutton clockwise (d).

## 6.6 TANK REFILL

### IMPORTANT



During refill the operator must be in the work area.

It is advisable, during the bottle refill phase, to submerge the bottles in cold water so as to reduce the pressure drop.

### WARNING



During bottle refill those not involved in the refill procedure must maintain a safety distance of at least 3 metres. Also, it is forbidden to disconnect the hoses from the fittings or the fill valve while the machine is under pressure.

The available bottle refill connectors are:

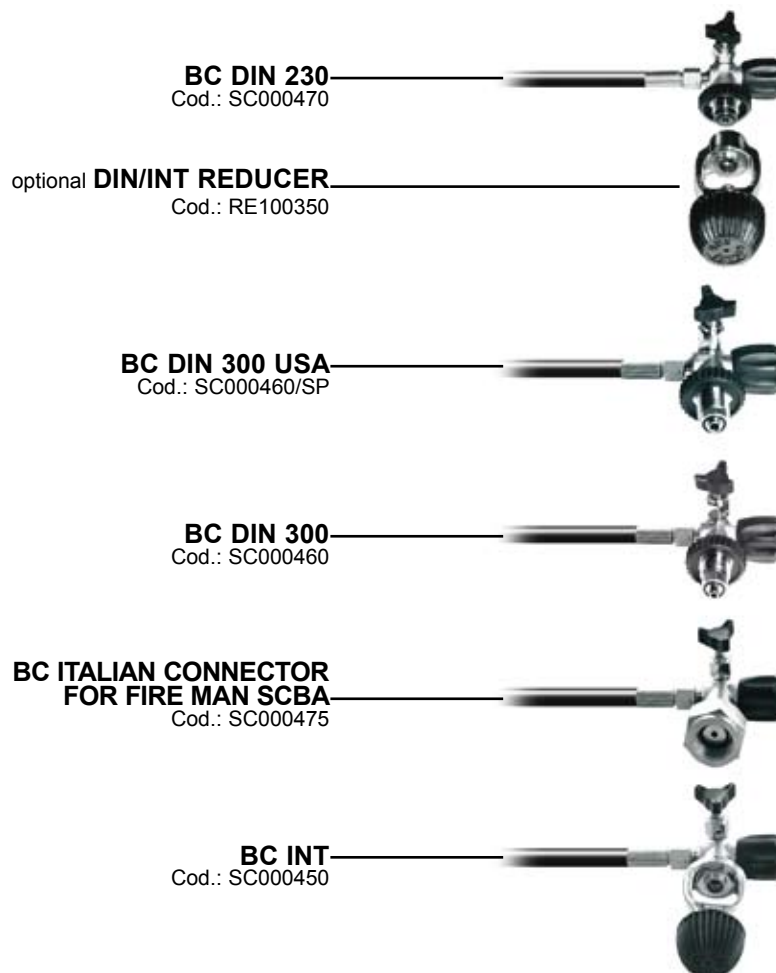



To refill bottles proceed as follows:

- Fit the hose connector (a) to the bottle valve (b).
- Screw in the fixing knob (c) until it is completely tightened.
- Check that the bleed valve (f) is closed by rotating it clockwise.
- Open the valve (d) by rotating it anticlockwise.
- Start the compressor.
- Open the valve (e) by rotating it anticlockwise.
- Start the compressor.
- When the refill has been completed shut the compressor down.
- Close valves (d) and (e) by rotating them clockwise.
- Open the bleed valve (f) by rotating it anticlockwise until all the residual air in the fitting has been expelled.
- Unscrew the fixing knob (c) by rotating it anticlockwise
- Disconnect the bottle coupling.

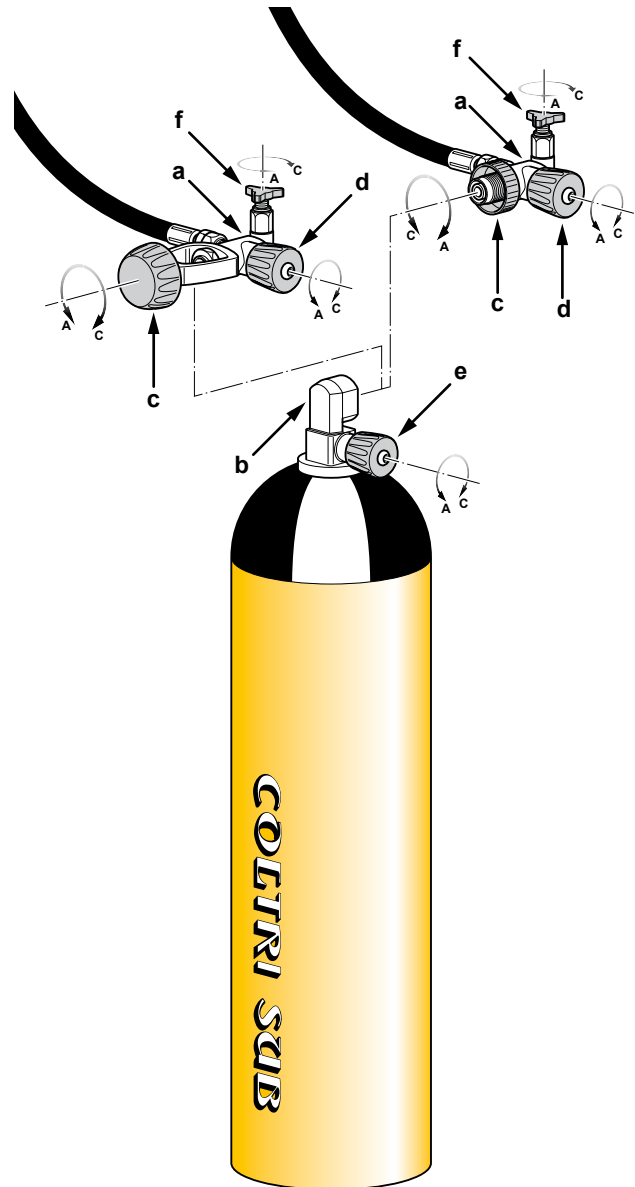

**WARNING**



Use only tested bottles (as proven by a test stamp and/or certificate). The working and bottle refill pressures are shown on the bottles themselves. It is forbidden to refill them at a pressure greater than that indicated.

**IMPORTANT**



If an emergency situation arises during refill shut down the compressor immediately (see "6.5 Starting and shutting down").

The compressor is nevertheless equipped with a safety system that shuts it down automatically when:

- The pressure setting on the pressure switch has been reached.
- The electrical power supply is temporarily cut.
- The electric motor overload device is tripped.

Following an emergency shutdown always make sure the cause of the emergency has been eliminated before proceeding with another refill.

## 7 - MAINTENANCE

**WARNING**

Maintenance tasks must only be carried out by the AEROTECNICA COLTRI Customer Assistance Service or qualified personnel.

**DANGER**

All maintenance tasks must be carried out with the compressor off and the power lead unplugged from the mains socket.

### 7.1 FOREWORD

To obtain the best possible performance from the compressor and ensure a long working life for all its parts it is essential that personnel follow the use and maintenance instructions with extreme diligence. It is thus advisable to read the information below and consult the manual every time an inconvenience arises. For further information please contact our assistance centre:

**Contact the AEROTECNICA COLTRI SpA. Maintenance Service Centre**

**Tel. +39 030 99 10 297**

**Fax. +39 030 99 10 283**

**e-mail: coltrisub@coltrisub.it**

### 7.2 GENERAL

- Proper preservation of the compressor requires thorough cleaning.
- This type of refill station, designed and built according to the most advanced technological criteria, requires only minimum preventive and routine maintenance.
- Before carrying out any maintenance tasks, run checks and/or controls on the compressor, switch off the compressor, remove the plug from the mains socket.
- The residual pressure present in the compressor (pumping circuit) must be released.
- During disassembly and re-assembly of the compressor, always use suitable wrenches/tools so as not to damage the relevant components.
- Loosen stiff parts with a copper or plastic mallet.
- When refitting parts make sure they are clean and lubricated sufficiently.
- Compressor maintenance tasks must only be carried out by authorised personnel and recorded in the chapter "11 Maintenance register" of this manual.

### 7.3 UNSCHEDULED WORK

Involves repair and/or replacement of the mechanical parts of one or more compressor components: this work normally needs doing only after some years of use. If substantial modifications are made, the manufacturer cannot be held liable for any dangers that might arise.

This work must be carried out by the assistance centre.



**7.4 SCHEDULED MAINTENANCE TABLE**

Maintenance	5 hours	10 hours	30 hours	40 hours	50 hours	250 hours	500 hours	1000 hours	2000 hours	3000 hours	4000 hours
Condensate discharge	○	○			○						
Automatic shutdown check		○			○						
Lubricating oil level check					○						
Main functions check						○					
Clean condensate discharge valves						○					
Condensate discharge O-rings							●				
Condensate discharge valves									●		
Belt wear and tension						○		●			
Cleaning the separator filter element						○		●			
Oil change						●					
1 <sup>st</sup> , 2 <sup>nd</sup> stage valves							○	●			
3 <sup>rd</sup> stage valves							●				
HP water/oil separator										●	
HP filter body										●	
1 <sup>st</sup> , 2 <sup>nd</sup> stage segments									●		
3 <sup>rd</sup> stage segments								●			
Check and replace HP flex hoses							○	●			
Fitting/hose leak							○				
General check-up							○				
Pumping unit, general overhaul								○			
1 <sup>st</sup> and 2 <sup>nd</sup> stage safety valves									●		
Safety valve								●			

○ Checking and cleaning    ● Change

**7.5 TROUBLESHOOTING**

Problem	Cause	Solution
The electric motor does not start	Phase missing	Check fuses or condenser
Rotation speed and flow rate decrease	Motor power too low The belt slips	Check the motor and the line Restore proper belt tension
The flow rate diminishes without rpm decreasing	Valves not working 4 th stage piston worn Fittings loose / leaking seals  Intake filter clogged Intake extension kinked Piston or piston rings worn	Contact technical assistance Contact technical assistance Check for leaks with soapy water and eliminate them Replace filter Straighten, use stiffer pipe Contact technical assistance
Air smells of oil	Filter cartridge exhausted Piston rings worn	Replace Contact technical assistance
Compressor overheats	Direction of rotation wrong Cooling tubes dirty Incomplete valve closure (causing overload of another stage)	Correct direction of rotation Contact technical assistance Contact technical assistance

## 7.6 CHECKING AND CHANGING THE LUBRICATING OIL

After putting the compressor into service the lubricating oil must be changed after the first 50 working hours. The lubricating oil must be changed every 250 hours working hours or annually.

**IMPORTANT** The compressor must be placed on a solid surface with a tilt of no more than 5°.



### DANGER



Do not carry out these tasks if the compressor has only just shut down; wait for the compressor to cool.

Any oil spilt during the oil/filter change could cause personnel to slip; wear protective garments and anti-slip footwear and remove any traces of oil immediately.

Both oil and filter are classified as special wastes and must therefore be disposed of in compliance with the anti-pollution laws in force.

All maintenance work must be carried out with the compressor OFF and the power supply lead unplugged from the mains socket.

### 7.6.1 Oil table

Sump capacity	litres / Quart	1,8
Recommended oils		COLTRI OIL CE750 CHEMLUBE 751 ANDEROL 755

### 7.6.2 Checking the oil level

Check that the level of lubricating oil (a) is within the allowed limits.

Note that an excessive quantity of oil can cause infiltrations in the cylinders and leave deposits on the valves while too low a level prevents proper lubrication and could cause engine seizure.

If the oil level is not within the minimum and maximum limits top up or drain as described in section "7.6.3 Changing the lubricating oil".

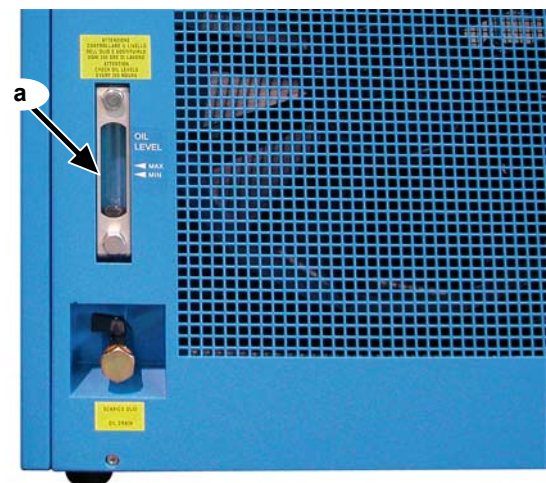

### 7.6.3 Changing the lubricating oil

The lubricating oil must be changed every 250 working hours or annually. To change the oil proceed as described:

- position a recipient under the drain plug (a) so that the oil flows into the exhausted oil recipient (recipient capacity of at least 2 litres required).
- loosen the top-up plug (b)
- remove the plug (d), open the tap (a) and drain all the oil;
- close the drain plug (a)
- open the top plug (b)
- fill the oil sump with 1.8 litres of oil from top oil plug (see "7.6.1 Oil table")
- close the oil top plug (b).
- switch on the compressor and run it depressure area for 30 seconds
- switch off the compressor and remove the plug from the power socket
- check the oil level (c); if the oil level is not within the allowed limits top up or drain.
- replace the cap (d).

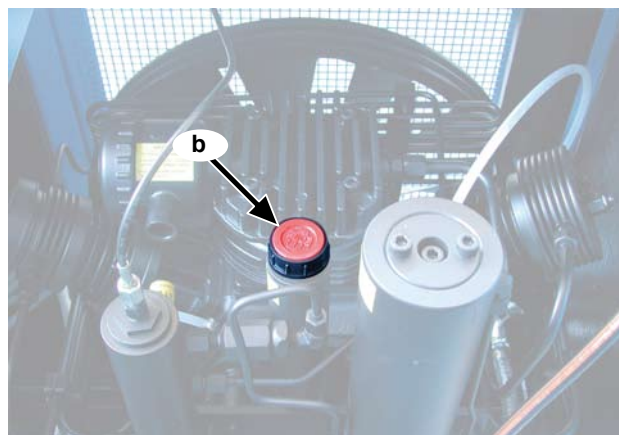
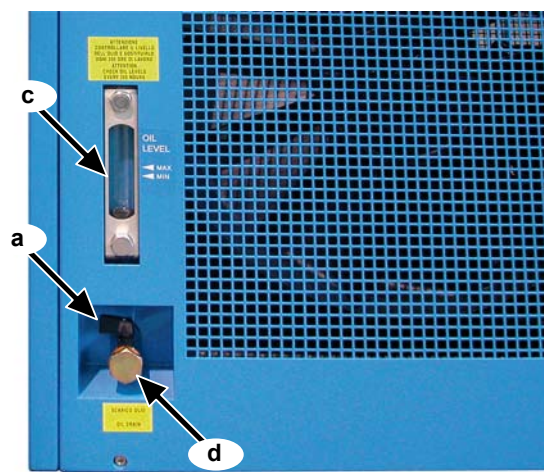

## 7.7 CHANGING THE INTAKE FILTER

After putting the compressor into service the intake filter must be changed after the first 50 working hours.

The air filter must then be changed every 250 working hours or annually.

Rotate the filtration cartridge in the filter by 90° every 50 hours.

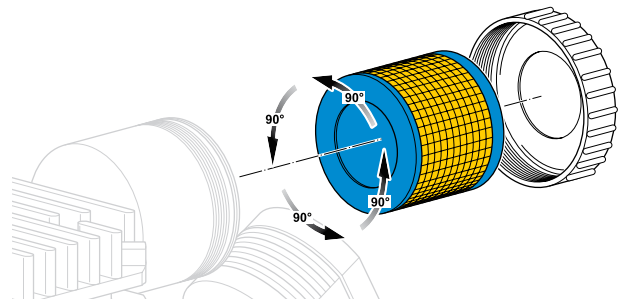

### DANGER



Do not carry out these tasks if the compressor has only just shut down; wait for the compressor to cool.

All maintenance work must be carried out with the compressor OFF and the power supply lead unplugged from the mains socket.

The air intake filter must be changed every 250 working hours or annually.

To change the filter proceed as follows:

- turn the air filter cover (a) by rotating it anticlockwise;
- remove the air filter cartridge (b);
- replace the cartridge with a new one;
- re-close the cover (a): screw it back on clockwise.

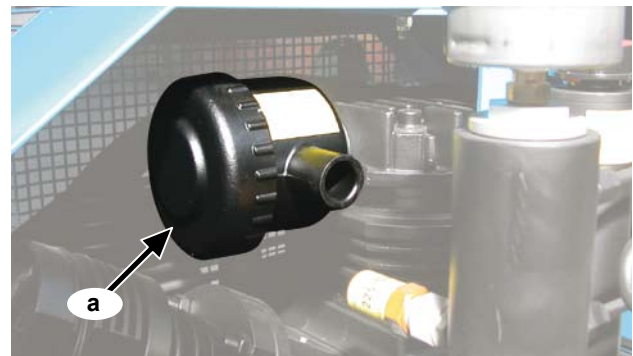

### IMPORTANT



If the compressor is used in a dusty environment the filter change interval should be reduced to every 100 hours.

## 7.8 CHECKING THE SAFETY VALVE

The final safety valve protects bottles from being filled with air at too high a pressure; the valve setting is made at the time of testing the compressor.

The safety valve must be tested every time bottles are refilled.

After attaching the coupling to the bottle start the compressor with the bottle valves closed.

Once you have checked, using the gauge, that the safety valve trips properly at maximum working pressure, open the valves and start the refill.

### IMPORTANT



Should the safety valve fail to operate properly contact the AEROTECNICA COLTRI technical assistance service.



**7.9 CONDENSATE DISCHARGE**

**IMPORTANT** The condensate can must be emptied at the end of every working day.



**DANGER**



Do not carry out these tasks if the compressor has only just shut down; wait for the compressor to cool.  
All maintenance work must be carried out with the compressor OFF and the power supply lead unplugged from the mains socket.

Condensation accumulates in the condensate separator; the condensate must be discharged every 10-15 minutes of compressor use.

Condensate discharge occurs automatically every 7 minutes. The yellow TEST PURGE pushbutton (b) must be pressed every day to make sure that the discharge valve is working properly. The condensate is collected in a can (c); periodically check this can to prevent overflow and consequent leakage of the condensate liquid. To empty the can remove it from the outside via the aperture on the side frame, remove the condensate drain hoses (d) from the fittings (e), empty the can and collect the condensate in a container; re-insert the hoses (d) and put the can back in its housing.

If the condensate needs to be drained manually, use the drain taps (a) and collect the condensate in a suitable container. Re-close the taps.

Every 250 hours it is necessary to replace the **SINTERED FILTER** inside the solenoid valve fitting (f).

Condensate must be disposed of according to the instructions shown in section "9.1 Waste disposal".

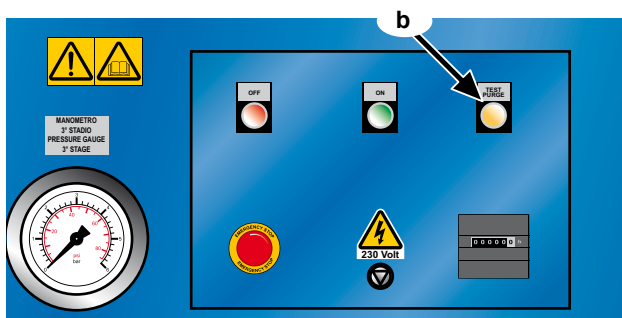
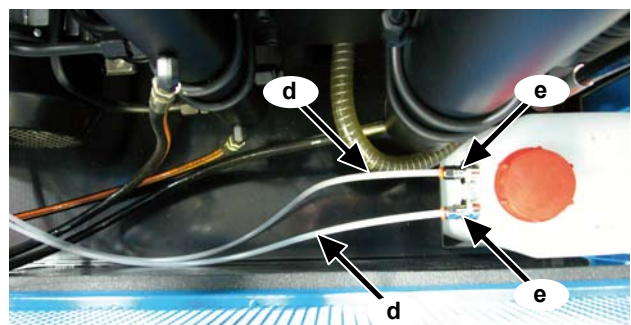
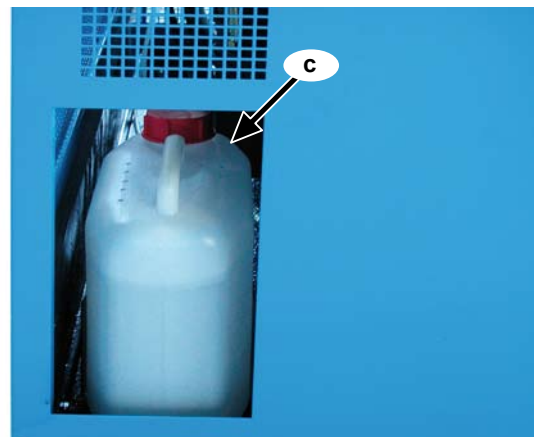
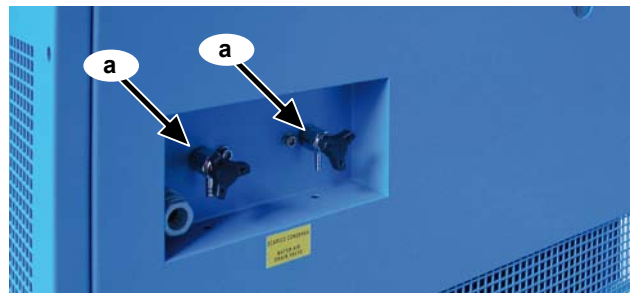

## 7.10 TRANSMISSION BELT

Belt tension must be checked monthly.

The transmission belts must be replaced every 500 working hours of the compressor.

### DANGER



**Do not carry out these tasks if the compressor has only just shut down; wait for the compressor to cool.**

**All maintenance work must be carried out with the compressor OFF and the power supply lead unplugged from the mains socket.**

### 7.10.1 Checking transmission belt tension

To check the tension on the belt (a) exert a pressure of approximately 10 Kg on the belt; check that the belt does not flex by more than 1 cm with respect to its original position.

Should it flex more than this replace the belt.

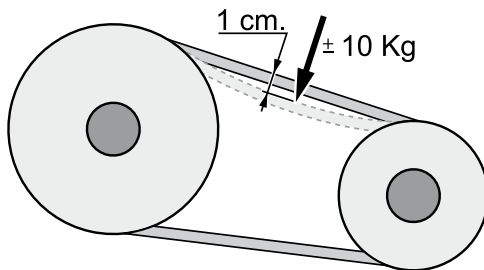

### 7.10.2 Changing transmission belt

To change a belt proceed as follows:

- insert a screwdriver (a) between the belt (b) and the motor pulley (c).
- take the belt out of the pulley groove.
- replace the belt with a new one, making sure that model and length are correct: check that the characteristics of the new belt are identical to the old one.
- insert the belt in the groove of the motor pulley (c).
- insert the belt in the groove of the compressor pulley (d): turn the pulley by hand until the belt slips into the pulley groove perfectly (second diagram).
- check that the belt is inserted perfectly in the grooves of both pulleys and that belt tension is correct.

If the tension of the new belt still fails to comply with the necessary requisites contact **AEROTECNICA COLTRI** assistance service.

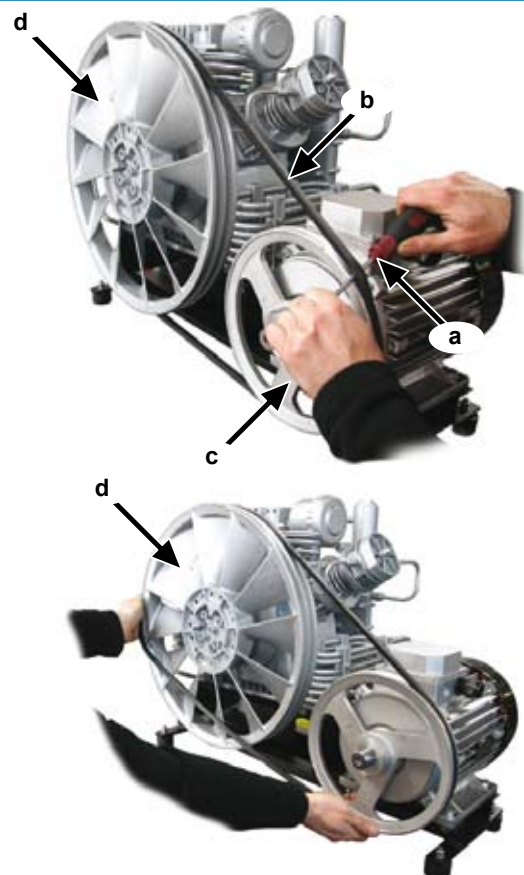

### 7.11 ACTIVE CARBON FILTER / MOLECULAR SIEVE

The active carbon filter must be replaced at intervals calculated on the basis of the characteristics of the environment in which the compressor is located. To calculate these intervals refer to the table below.

The filter must nevertheless be replaced before the air becomes malodorous.

**IMPORTANT** If the compressor is used in an environment where CO (exhaust fumes) may be present it is compulsory to use CO-fixing filters; these can be supplied on request.



**IMPORTANT** For compressors used in the USA and CANADA the use of LAWRENCE FACTOR filtration cartridges is recommended.



**DANGER** Do not carry out these tasks if the compressor has only just shut down; wait for the compressor to cool.  
 All maintenance work must be carried out with the compressor OFF and the power supply lead unplugged from the mains socket.  
 Depressurise the entire compressor circuit before carrying out any maintenance tasks.



#### 7.11.1 Filter replacement frequency calculation table

Temp. (°C)	Temp. (°F)	Correction factor	Filter duration (hours) MCH-8	Filter duration (hours) MCH-11	Filter duration (hours) MCH-13-26	Filter duration (hours) MCH-16-32	Filter duration (hours) MCH-18
50	122	0,2	(70x0,2)=14	(55x0,2)=11	(50x0,2)=10	(40x0,2)=8	(36x0,2)=7
40	104	0,34	(70x0,34)=24	(55x0,34)=19	(50x0,34)=17	(40x0,34)=14	(36x0,34)=12
30	86	0,57	(70x0,57)=40	(55x0,57)=31	(50x0,57)=28	(40x0,57)=23	(36x0,57)=20
<b>20</b>	<b>68</b>	<b>1</b>	<b>70</b>	<b>55</b>	<b>50</b>	<b>40</b>	<b>36</b>
10	50	1,2	(70x1,2)=78	(55x1,2)=66	(50x1,2)=60	(40x1,2)=48	(36x1,2)=43
5	41	1,4	(70x1,4)=98	(55x1,4)=77	(50x1,4)=70	(40x1,4)=56	(36x1,4)=50
0	32	1,6	(70x1,6)=112	(55x1,6)=88	(50x1,6)=80	(40x1,6)=64	(36x1,6)=57

#### 7.11.2 Changing the active carbon filter / molecular sieve

To change the active carbon filters (a) proceed as follows:

- vent all the compressed air inside the circuit.
- use the tool (b) to lever the screw heads (d) on the plug (c) and rotate counter clockwise.

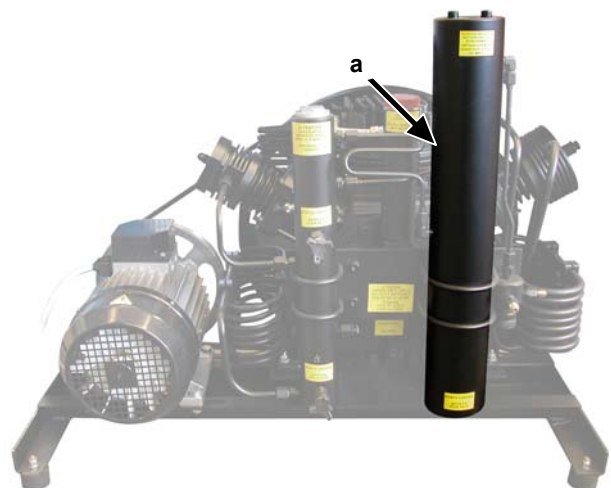
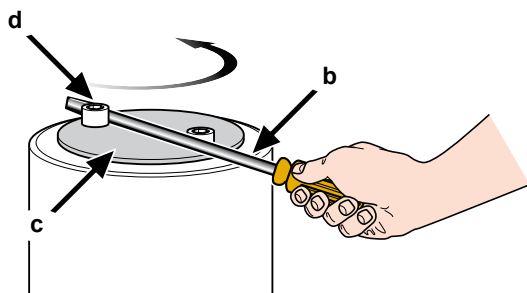

- remove the filter plug (c).
- unscrew the cartridge (e) from the plug (c).
- replace the cartridge (e) with a new one.
- screw the new cartridge onto the plug (c).
- close the filter plug (c) and tighten with the wrench (b).

There are O-rings on the filter plug and cartridge (f-g). If these O-rings deteriorate air is vented through the cap (c).

If you notice any venting replace the O-rings.

When changing the O-rings observe the precautions described at the beginning of the relevant section of the manual.

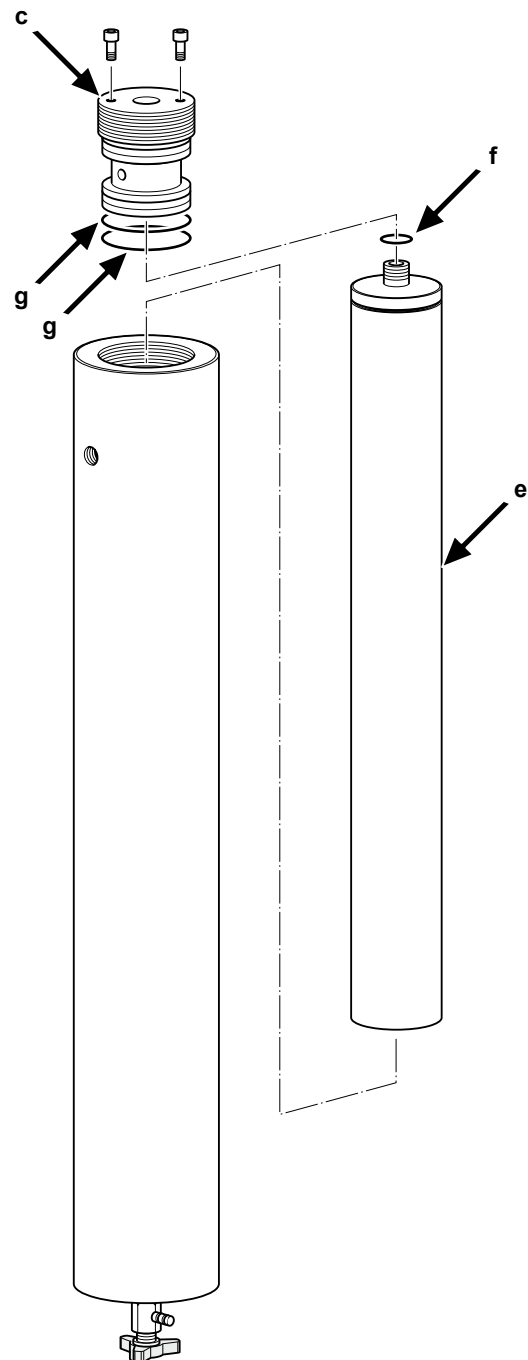
**WARNING**

The active carbon filters are classified as special waste: they must be disposed of in compliance with the anti-pollution standards in force.

**IMPORTANT**

It is essential that there be a filtration cartridge (e) inside the active carbon filters (a) every time the compressor is used.



## 7.12 CHANGING THE FLEX HOSES

### IMPORTANT



The hoses must be changed periodically (every 3 years or ever 1000 hours) or when they show signs of abrasion/wear/damage.

The bending radius of the hoses must not be less than 250 mm.

### DANGER



Do not carry out these tasks if the compressor has only just shut down; wait for the compressor to cool.

All maintenance work must be carried out with the compressor OFF and the power supply lead unplugged from the mains socket.

Vent the air from the compressor before carrying out any maintenance tasks.

Tank refill pressure is very high; therefore, before refilling the tanks check that the hoses are perfectly connected and in good condition. Check also that the valves on any unused hoses are closed properly so as to prevent the dangers that derive from hose whiplash.

When the tanks are being refilled unauthorised personnel must remain at a distance of at least 3 metres.

It is strictly forbidden to disconnect the hoses from the fittings or refill valve when the machine is under pressure.

To change the bottle refill hoses proceed as follows:

- disconnect the bottle refill hoses by unscrewing the fittings (a) (17 mm wrench).
- replace the old hoses with new ones.
- screw the hoses onto the connectors (a).
- use a dynamometric wrench to tighten the hoses on the compressor with a torque of 15 Nm.

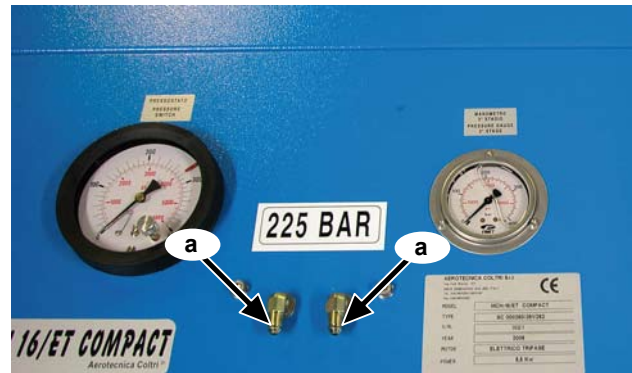

## 8 - STORAGE

Should the compressor not be used, it must be stored in a dry sheltered area at an ambient temperature of between 0 °C and 40 °C.

Store the compressor away from sources of heat, flames or explosive.

### 8.1 STOPPING THE MACHINE FOR A BRIEF PERIOD

If you do not intend to use the compressor for a brief period proceed with general cleaning.

### 8.2 STOPPING THE MACHINE FOR A LONG PERIOD

If you do not intend to use the compressor for a long period, extract the active carbon filter cartridge.

Run the compressor for a few minutes without actually filling bottles so as to flush out all the residual condensate. Stop the compressor, disassemble the intake filter, restart the compressor and spray a few drops of oil into the air intake hole so that a light film of lubricant is aspirated and penetrates the interior of the compressor. Stop the compressor and refit the air intake filter. Clean the external parts: eliminate any moisture, salt or oil deposits. Protect the compressor from dust and water by storing it in a clean, dry place.

Switch off the machine via the main switch and remove the plug from the mains power socket.

Proceed with a thorough general clean of all machine parts.

During machine downtimes it is advisable to run the compressor for 20 minutes every 15 days.

## 9 - DISMANTLING AND PUTTING OUT OF SERVICE

Should you decide not to use the compressor or any of its parts any longer you must proceed with its dismantling and putting out of service.

These tasks must be carried out in compliance with the standards in force.

### WARNING



Should the compressor, or a part of it, be out of service its parts must be rendered harmless so they do not cause any danger.

### WARNING



Bear in mind that oil, filters or any other compressor part subject to differentiated waste collection must be disposed of in compliance with the standards in force.

### 9.1 WASTE DISPOSAL

Use of the compressor generates waste that is classified as special. Bear in mind that residues from industrial, agricultural, crafts, commercial and service activities not classified by quality or quantity as urban waste must be treated as special waste. Deteriorated or obsolete machines are also classified as special waste.

Special attention must be paid to active carbon filters as they cannot be included in urban waste: observe the waste disposal laws in force where the compressor is used.

Bear in mind that it is compulsory to record loading/unloading of exhausted oils, special wastes and toxic-harmful wastes that derive from heavy/light industry processes. Exhausted oils, special wastes and toxic-harmful waste must be collected by authorised companies.

It is especially important that exhausted oils be disposed of in compliance with the laws in the country of use.

### 9.2 DISMANTLING THE COMPRESSOR

#### IMPORTANT



Disassembly and demolition must only be carried out by qualified personnel.

Dismantle the compressor in accordance with all the precautions imposed by the laws in force in the country of use. Before demolishing request an inspection by the relevant authorities and relative report.

Disconnect the compressor from the electrical system.

Eliminate any interfaces the compressor may have with other machines, making sure that interfaces between remaining machines are unaffected.

Empty the tank containing the lubricating oil and store in compliance with the laws in force.

Proceed with disassembly of the individual compressor components and group them together according to the materials they are made of: the compressor mainly consists of steel, stainless steel, cast iron, aluminium and plastic parts.

Then scrap the machine in compliance with the laws in force in the country of use.

#### IMPORTANT



At every stage of demolition observe the safety regulations contained in this manual carefully.

## 10 - INSTRUCTIONS FOR EMERGENCY SITUATIONS

### 10.1 FIRE

In the event of fire use a CO<sub>2</sub> extinguisher in compliance with the relevant standards in force.

Contact the fire brigade.

## 11 - MAINTENANCE REGISTER

### 11.1 ASSISTANCE SERVICE

Customers continue to receive assistance after the purchase of a compressor.  
To this end **AEROTECNICA COLTRI** has created an assistance network covering the entire country.

#### IMPORTANT



**Our qualified technicians are at your disposal at any time to carry out maintenance work or repairs; we use only original spare parts so as to ensure quality and reliability.**

### 11.2 SCHEDULED MAINTENANCE

The scheduled maintenance programme is designed to keep your compressor in perfect working order. Some simple tasks, described in this manual, can be carried out directly by the customer; others, instead, require that the work be carried out by trained personnel. For the latter we recommend you always contact our assistance network.

This section provides a simple tool with which to request assistance and register completed scheduled maintenance work.

Start-up and maintenance checks/tasks, once completed by our qualified technician, are registered in this maintenance chapter by way of an official stamp, signature and inspection date; the number of working hours is also registered.

The maintenance schedules/coupons easily let you know when our assistance service should be contacted to carry out work.

### 11.3 USING THE COMPRESSOR UNDER HEAVY-DUTY CONDITIONS

Where compressors are used in particularly difficult conditions (high levels of pollution, presence of solid particulate in suspension etc.), scheduled maintenance tasks must be carried out more frequently as per the advice given by our assistance network.

### 11.4 THE CUSTOMER CARE CENTRE

Our qualified technicians are constantly in contact with the head offices of our company where there is an assistance network coordination and support centre, better known as the Customer Care Centre.

To contact us:

Telephone: **+39 030 9910301**

**+39 030 9910297**

Fax: **+39 030 9910283**

E-mail: **coltrisub@coltrisub.it**

**11.5 SCHEDULED MAINTENANCE REGISTRY COUPONS**

Type of work and notes	Date
<p>.....</p> <p>.....</p> <p>.....</p> <p>.....</p> <p>.....</p>	<p>                                                                                          </p>
	'Assistance' service stamp
	<p>.....</p>
	Maintenance technician's signature
	<p>.....</p>

Type of work and notes	Date
<p>.....</p> <p>.....</p> <p>.....</p> <p>.....</p> <p>.....</p>	<p>                                                                                          </p>
	'Assistance' service stamp
	<p>.....</p>
	Maintenance technician's signature
	<p>.....</p>

Type of work and notes	Date
<p>.....</p> <p>.....</p> <p>.....</p> <p>.....</p> <p>.....</p>	<p>                                                                                          </p>
	'Assistance' service stamp
	<p>.....</p>
	Maintenance technician's signature
	<p>.....</p>

Type of work and notes	Date
..... ..... ..... ..... ..... ..... ..... ..... ..... .....	_____ 
	<b>'Assistance' service stamp</b>
	_____ _____ _____ _____ _____ _____ _____ _____ _____ _____
	<b>Maintenance technician's signature</b>

Type of work and notes	Date
..... ..... ..... ..... ..... ..... ..... ..... ..... .....	_____ 
	<b>'Assistance' service stamp</b>
	_____ _____ _____ _____ _____ _____ _____ _____ _____ _____
	<b>Maintenance technician's signature</b>

Type of work and notes	Date
..... ..... ..... ..... ..... ..... ..... ..... ..... .....	_____ 
	<b>'Assistance' service stamp</b>
	_____ _____ _____ _____ _____ _____ _____ _____ _____ _____
	<b>Maintenance technician's signature</b>

Type of work and notes	Date				
<p>.....</p> <p>.....</p> <p>.....</p> <p>.....</p> <p>.....</p> <p>.....</p> <p>.....</p> <p>.....</p> <p>.....</p>	<table border="1" style="width: 100%; border-collapse: collapse;"> <tr> <td style="width: 25%; height: 15px;"> </td> <td style="width: 25%; height: 15px;"> </td> <td style="width: 25%; height: 15px;"> </td> <td style="width: 25%; height: 15px;"> </td> </tr> </table>				
	<b>'Assistance' service stamp</b>				
	<b>Maintenance technician's signature</b>				

Type of work and notes	Date				
<p>.....</p> <p>.....</p> <p>.....</p> <p>.....</p> <p>.....</p> <p>.....</p> <p>.....</p> <p>.....</p> <p>.....</p>	<table border="1" style="width: 100%; border-collapse: collapse;"> <tr> <td style="width: 25%; height: 15px;"> </td> <td style="width: 25%; height: 15px;"> </td> <td style="width: 25%; height: 15px;"> </td> <td style="width: 25%; height: 15px;"> </td> </tr> </table>				
	<b>'Assistance' service stamp</b>				
	<b>Maintenance technician's signature</b>				

Type of work and notes	Date				
<p>.....</p> <p>.....</p> <p>.....</p> <p>.....</p> <p>.....</p> <p>.....</p> <p>.....</p> <p>.....</p> <p>.....</p>	<table border="1" style="width: 100%; border-collapse: collapse;"> <tr> <td style="width: 25%; height: 15px;"> </td> <td style="width: 25%; height: 15px;"> </td> <td style="width: 25%; height: 15px;"> </td> <td style="width: 25%; height: 15px;"> </td> </tr> </table>				
	<b>'Assistance' service stamp</b>				
	<b>Maintenance technician's signature</b>				







**COLTRI SUB ASIA PACIFIC**

50/100 M2, Chaloemphrakiat Ratchakan Thi 9 rd Soi 48  
Dockmai Prawet Bangkok 10250 Thailand  
Tel: +66 2 7266100-2  
Fax: +66 2 7266106  
Mobile: +66 81 8913937  
www.coltrisub-asiapacific.com  
e-mail: info@coltrisub-asiapacific.com  
cesareb@loxinfo.co.th

**COLTRI SUB EGYPT**

El Rowayset (Industrial Area)  
Sharm El Sheikh - South Sinai - Egypt  
Tel: +20 (0) 366 44 74  
Fax: +20 (0) 366 44 73  
www.coltrisubegypt.com  
e-mail: info@coltrisubegypt.com  
bruno@coltrisubegypt.com  
tim@coltrisubegypt.com

**COLTRI AMERICAS**

12493 NW 44th Street, Unit5  
Coral Springs, FL 33065  
Tel: 1-954-344-2420  
Fax: 1-954-344-2421  
www.coltriamericas.com  
e-mail: info@coltriamericas.com  
david@coltriamericas.com

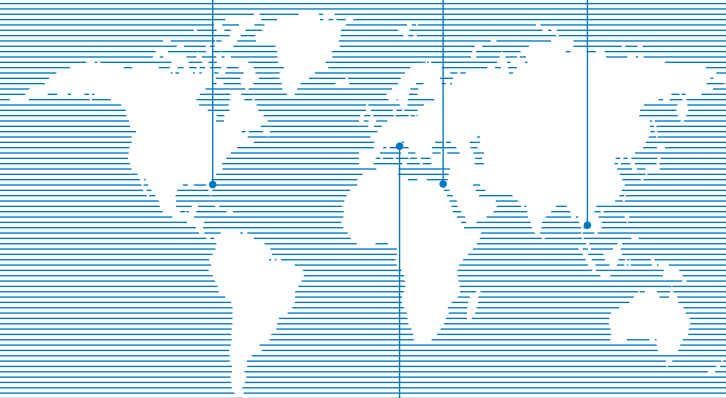
**AEROTECNICA COLTRI®**

AEROTECNICA COLTRI Spa  
Via Colli Storici, 177  
25010 SAN MARTINO DELLA BATTAGLIA (BS) ITALY  
Tel. +39 030 9910301  
Fax. +39 030 9910283  
www.coltrisub.it  
www.coltrisub.com  
coltrisub@coltrisub.it

[www.coltrisub.com](http://www.coltrisub.com)