

Teileliste
Spare parts list
Catalogue des pièces

TU - 2/3

UTILUS

UTILUS - H

2/3 Auflage · April 1991

2/3 Edition · April 1991

2/3 Edition · Avril 1991

Hochdruckkompressoren
High pressure compressors
Compresseurs à haute pression

TEILELISTE TU-2/3

ist gültig ab: April 1991

für
Kompressortyp:

PARTS LIST TU-2/3

is valid as of: April 1991

for
Compressor model:

CATALOGUE DES PIECES TU-2/3

est valable à partir d'Avril 1991

pour
Type de compresseur:

PN 200	PN 300	Fabrik-Nr./ Serial No./ No. de fabrication
	U1-H, U3E-H	XXX-XXXX/9/7
	U2B-H, U3W-H, U4D-H, U2B-H*	XXX-XXXX/9/8
U1, U3E	U3E-H*, U3W-H*	XXX-XXXX/9/9
U2B, U2B*, U3W, U4D		XXX-XXXX/9/10
U3E*, U3W*		XXX-XXXX/9/11
U4DA	U4DA-H	XXX-XXXX/9/12

* Mit Sturzrahmen

* With protection frame

* Avec cadre de protection

Die hier enthaltenen Beschreibungen und Abbildungen sind unverbindlich; BAUER-Kompressoren behält sich daher im Interesse der Weiterentwicklung das Recht vor, jederzeit an Hauptgruppen und einzelnen Bestand- oder Zubehörteilen die Änderungen vorzunehmen, die sie unter Beibehaltung der wesentlichen Merkmale der hier beschriebenen Typen, zur Steigerung der Leistungsfähigkeit oder aus irgendeinem sicherheits- oder handelstechnischen Grund für zweckmäßig hält.

BAUER-Kompressoren ist ferner nicht verpflichtet, vorliegende Dokumentation diesbezüglich gleichzeitig zu berichtigen.

All information and illustrations are without obligation - we reserve the right to make changes to all individual items and accessories according to state of the art requirements in improving performance or as necessitated by safety or commercial restrictions.

BAUER Kompressoren is, in addition, not obliged to up-date these operating instructions accordingly simultaneously with change.

Les descriptions et illustrations contenues dans ce manuel sont sans engagement de notre part; dans l'intérêt du développement ultérieur de nos appareils, nous nous réservons donc le droit de procéder, à tout moment, sur les groupes principaux et sur chaque élément ou accessoire de nos appareils, aux modifications qui, tout en respectant les caractéristiques essentielles des types ici décrits, nous sembleront nécessaires pour augmenter le rendement de nos appareils ou pour toute autre raison commerciale ou de sécurité.

BAUER-Kompressoren n'est pas non plus obligé de procéder, en même temps, à la révision correspondante de la présente documentation.

Wichtige Hinweise für Teilebestellung:

Bestell-Nr., die mit der Ziffer 0 beginnen, bezeichnen Teile, die komplett geliefert werden.

Teile ohne Bestell-Nr. sind nur zur Information für die Montage aufgeführt. Diese Teile sind nicht als Ersatzteile erhältlich.

Bei Ersatzteilbestellungen erwarten Sie unsere richtige Lieferung; deshalb benötigen wir von Ihnen folgende Angaben:

1. Kompressortyp: UTILUS
2. Fabrik-Nr.
3. Stückzahlen
4. Benennung und Bestell-Nr. des gewünschten Teils

Bestell-Beispiel:

Für Utilus, Kompressor Nr. 529-0867
3 Dichtungen Nr. N 4466



Ersatzteilsätze

Klassifizierung:

- 0 = Dichtungssatz; Bestell-Nr. N 6199
- 2 = Wartungssatz, 2 Jahre; Bestell-Nr. N 6200
- 5 = Wartungssatz, 5 Jahre; Bestell-Nr. N 6201

In den Spalten ist jeweils die im entsprechenden Satz enthaltene Teile-Stückzahl angegeben

ACHTUNG:

Nur Schrauben und Stiftschrauben der Qualität 8.8 verwenden!

Important notes for spare parts orders:

Part Nos. beginning with digit 0 indicate parts available as complete assemblies.

Parts without Part No. are indicated for assembly reference only. These parts are not available as single parts.

When placing an order for spare parts, please give the following items so as to ensure our correct delivery:

1. Compressor model: UTILUS
2. Serial No.
3. Quantity req'd
4. Name and Part No.

Example for order:

For Utilus, serial-no. 529-0867
3 gaskets N 4466



Spare Parts Sets

Classification:

- 0 = Set of gaskets; Part No. N 6199
- 2 = Maintenance kit, 2 years; Part no. N 6200
- 5 = Maintenance kit, 5 years; Part no. N 6201

The columns contain the number of parts that are included in the respective parts set

ATTENTION:

Use only screws and studs in quality 8.8. This quality is equivalent to SAE J 429 d grade 5.

Avis important pour la commande de pièces

Les nos. de commande commençant par le chiffre 0 indiquent des pièces livrées au complet.

Les pièces sans no. de commande sont indiquées uniquement pour information de montage. Elles ne sont pas livrables individuellement.

Pour que la livraison de pièces de rechange corresponde à votre commande, veuillez bien nous fournir les données suivantes:

1. Type du compresseur: UTILUS
2. No. de fabrication
3. Quantité désirée
4. Désignation et no. de cde. de la pièce désirée

Exemple de commande:

Pour Utilus, compresseur no. 529-0867
3 joints N 4466



Kits de pièces détachées

Classification:

- 0 = Kit de joints d'étanchéité; No. de cde. N 6199
- 2 = Kit d'entretien pour 2 ans; No. de cde. N 6200
- 5 = Kit d'entretien pour 5 ans; No. de cde. N 6201

La composition des kits est indiquée dans les colonnes de gauche.

ATTENTION:

N'utiliser que des vis et des goujons filetés de la qualité 8.8

TEILELISTE TU-2/3

SPARE PARTS LIST TU-2/3

CATALOGUE DES PIECES TU-2/3

INHALTSVERZEICHNIS

INDEX

TABLE DES MATIERES

Kurbelgehäuse mit Zubehör,
 Triebwerk, Kolben, Zylinder
 Ventilkopf 1. Stufe
 Ventilkopf 2. Stufe
 Ventilkopf 3. Stufe
 Kühler und Ventilator
 Öldruckschmierung
 Ansaugfilter mit Ansaugschlauch
 Zwischenfilter und Sicherheitsventile
 Filtersystem P21
 Umschalteinrichtung PN 200 / PN 300
 Grundrahmen
 Sturzrahmen
 Grundrahmen Dieselmotor
 Grundrahmen Dieselmotor mit Anlasser
 Antriebsmotoren

Kondensat-Ablaufautomatik 068222-342
 Kondensatablaufventil-Baugruppe

Kondensatablaufventil 064008-342
 Laufschaltwerke

Crankcase with accessories,
 driving gear, pistons and cylinders
 Valve head 1st stage
 Valve head 2nd stage
 Valve head 3rd stage
 Cooler and fan
 Lubrication system
 Intake filter with intake hose
 Interfilter and safety valves
 Filter system P21
 Change over device 3200 / 4700 psi
 Base frame
 Protection frame
 Base frame - Diesel engine
 Base frame - Diesel engine with electr. starter
 Driving motors

Automatic condensate drain 068222-342
 Condensate drain valve assembly

Condensate drain valve 064008-342
 Electrical timers

Carter de vilebrequin avec accessoires,
 embiellage, pistons et cylindres
 Culasse de 1er étage
 Culasse de 2e étage
 Culasse de 3e étage
 Refroidisseur et ventilateur
 Lubrification
 Filtre d'aspiration avec tuyau d'aspiration
 Séparateur intermédiaire, soupapes de sûreté
 Système de filtration P21
 Dispositif sélecteur PN 200 / PN 300
 Cadre
 Cadre de protection
 Cadre - moteur Diesel
 Cadre - moteur Diesel avec démarrage électr.
 Moteurs d'entraînement

Purge automatique des condensats 068222-342
 Soupape de purge des condensats, groupe
 d'assemblage
 Soupape de purge 064008-342
 Minuterics électriques

TU-1

TU-2

TU-3

TU-4

TU-5

TU-6

TU-7

TU-8

TU-9

TU-10

TU-11

TU-12

TU-13

TU-14

TU-15

KA-2

KA-3

KA-4

KA-5

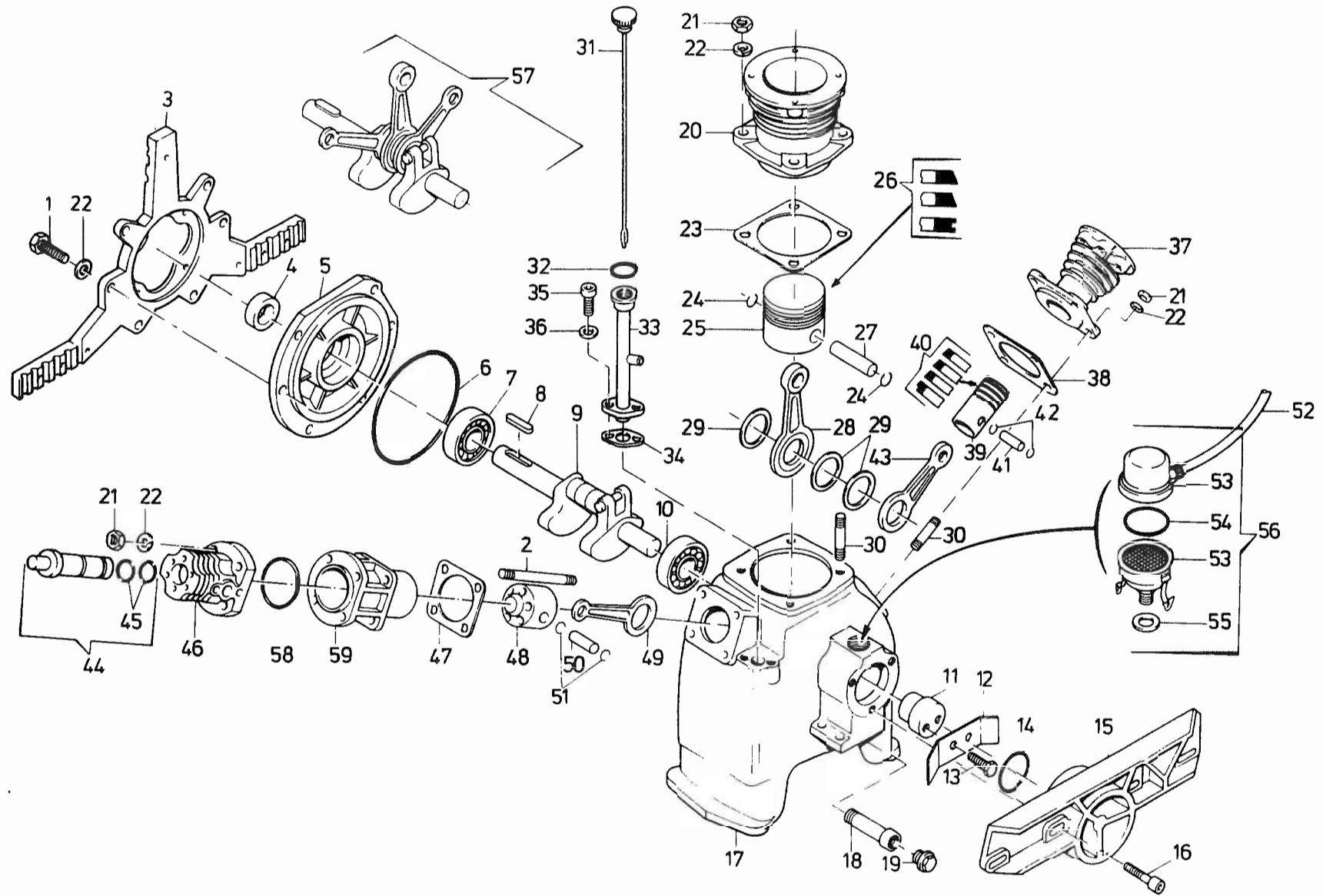



Ersatzteilsatz
Spare parts sets
Kits de pièces dét.

Bildtafel TU-1 Kurbelgehäuse mit Zubehör, Triebwerk, Kolben und Zylinder
Figure TU-1 Crankcase with accessories, driving gear, pistons and cylinders
Planche TU-1 Carter de vilebrequin avec accessoires, embiellage, pistons et cylindres

Klasse Class Classe			Pos.	Bestell-Nr Part No. No. de cde.	Benennung	Designation	Dénomination	Gewicht Weight Poids (kg)	Abmessungen Dimensions Dimensions
0	2	5							
			1	N 89	Sechskantschraube	Hex. screw	0.020	M 8 x 30	DIN 933
			2	N 4065	Stiftschraube	Stud	0.060	M 8 x 70	DIN 835
			3	14998-860	Kühlrohrhalterung	Bracket for cooler	0.695		
1			4	N 220	Wellendichtring	Shaft seal	0.017	Ø 25 x 40 x 7	
			5	14878-030	Lagerdeckel	Cover	0.560		
1	1		6	N 3705	O-Ring	O-ring	0.012	Ø 140 x3	
			7	N 3703	Zylinderrollenlager	Roller bearing	0.240	Ø 25 x 62 x 17	
			8	N 166	Paßfeder	Key	0.022	8 x 7 x 40	DIN 6885
			9	062981-010	Kurbelwelle kpl.	Crankshaft assy	2.064		
			10	N 3702	Zylinderrollenlager	Roller bearing	0.150	Ø 20 x 52 x 15	
			11	3196-650	Exzenter	Arbre à excentrique	0.125		
			12	14888-655	Sicherungsblech	Locking plate	0.003		
			13	N 53	Sechskantschraube	Hex. screw	0.005	M 6 x 16	DIN 933
1	1	1	14	N 3726	O-Ring	O-ring	0.004	Ø 40,2 x 3	
			15	58159-860	Filterhalterung	Filter mounting	0.970		
			16	N 109	Innensechskantschraube	Allen screw	0.020	M 8 x 30	DIN 912
			17	14874-000	Kurbelgehäuse	Crankcase	6.130		
			18	N 2911	Verlängerungsröhrchen	Extension	0.125	R 3/8"x120 lg	DIN 910
			19	N 3707	Verschlußschraube	Plug	0.030	R 3/8"	DIN 910
			20	14913-060	Zylinder, 1. Stufe	Cylinder, 1st stage	2.350	Ø 60	
			21	N 370	Sechskantmutter	Hex. nut	0.009	M 8	DIN 985
			22	N 58	Scheibe	Washer	0.005	Ø 8.4	DIN 125
1	1	3	23	1867-090	Dichtung	Gasket	0.003		
			24		Sicherungsring	Circlip	0.001		
			25	2002-050	Kolben	Piston	0.150	Ø 60	
			26	N 2001	Kolbenringsatz	Piston ring set	0.039	Ø 60	
			27		Kolbenbolzen	Piston pin			
			28	1502-040	Pleuel 1. Stufe	Piston-rod 1st stage	0.175		
			29	4180-040	Distanzscheibe	Spacer	0.005		
			30	N 215	Stiftschraube	Stud	0.025	M 8 x 25	DIN 835
			31	14886-650	Ölpeilstab	Oil dip stick	0.038		
1	1	1	32	N 3521	O-Ring	O-ring	0.005	Ø 21,82 x 3,53	
			33	14887-635	Öleinfüllstutzen	Oil filling pipe	0.040		
1	1	3	34	12560-090	Dichtung	Gasket	0.005	A 32x27x2	DIN 7603
			35	N 210	Innensechskantschraube	Allen screw	0.020	M 6 x 20	
			36	N 3026	Federscheibe	Lock washer	0.001	A 6	DIN 137
			37	10875-060	Zylinder, 2. Stufe	Cylinder, 2nd stage	1.300	Ø 36	
1	1	1	38	3110-090	Dichtung	Gasket	0.005	Ø 36	
			39	N 2634	Kolben 2. Stufe	Piston 2nd stage	0.095	Ø 36	
			40	N 4158	Kolbenringsatz	Piston ring set	0.006	Ø 36	
			41		Kolbenbolzen	Piston pin			
			42		Sicherungsring	Circlip			
			43	4960-040	Pleuel 2. Stufe	Piston-rod 2nd stage	0.180		
			44	014609-050	Kolbenbüchse kpl. mit Freiflugkolben	Piston and sleeve assy	0.270		

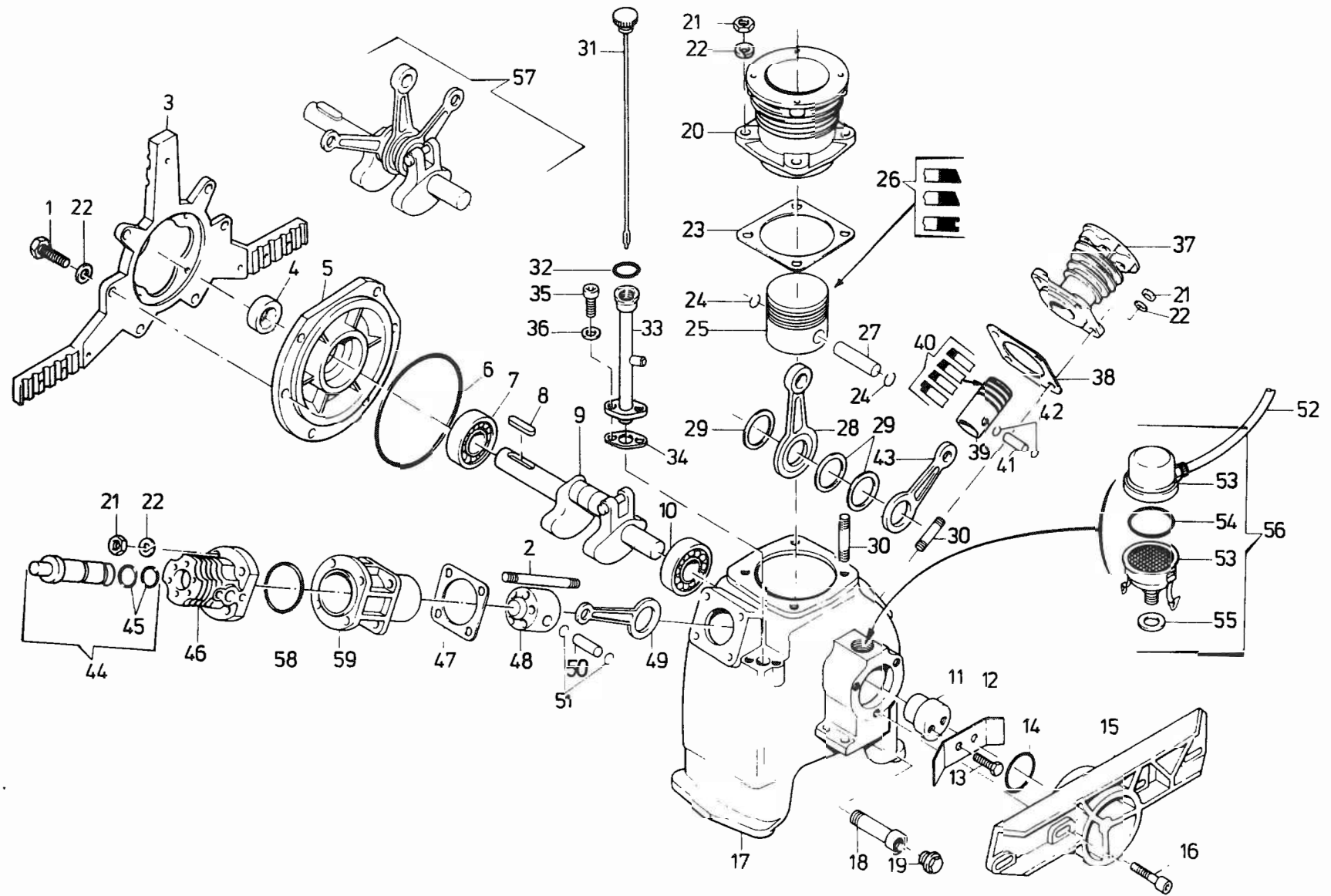



Ersatzteilsätze
Spare parts sets
Kits de pièces dét.

Bildtafel TU-1 Kurbelgehäuse mit Zubehör, Triebwerk, Kolben und Zylinder
Figure TU-1 Crankcase with accessories, driving gear, pistons and cylinders
Planche TU-1 Carter de vilebrequin avec accessoires, embiellage, pistons et cylindres

Klasse Class Classe			Pos.	Bestell-Nr Part No. No. de cde	Benennung	Designation	Dénomination	Gewicht Weight Poids (kg)	Abmessungen Dimensions Dimensions	
0	2	5								
2	2	6	45	N 2507	O-Ring	O-ring	Joint torique	0.005	Ø 18,77 x 1,78	
			46	56352-060	Zylinder-Oberteil, 3. Stufe	Cylinder, upper, 3rd stage	Cylindre, partie supérieure du 3e étage	0.500		
1	1	3	47	1866-090	Dichtung	Gasket	Joint	0.001	Ø 45	
			48	N 823	Führungskolben	Guide piston	Piston guide	0.110		
			49	1509-040	Pleuel 3. Stufe	Piston-rod 3rd stage	Bielle 3e étage	0.190		
			50		Kolbenbolzen	Pistonpin	Axe de piston			
			51		Sicherungsring	Circlip	Circlip			
			52	N 3736	Schlauch*	Hose*	Tuyau flexible*	0.165	Lw 6 x 1 x 200 lg.	
		1	53	N 3207	Dämpferfilter	Demister body	Silencieux du désaérateur	0.170		
1	1	1	54	N 3712	O-Ring	O-ring	Joint torique	0.005	Ø 63,22 x 1,78	
			55	N 293	Dichtring	Gasket	Joint	0.002	C 21x28x2 DIN 7603	
			56	014892-635	Kurbelgehäuse-Entlüfter	Demister assy	Désaérateur cpl.	0.172	A 21 x 28	
			57	013987-010	Triebwerk kpl.	Driving gear cpl.	Embiellage cpl.	2.400		
1	1	3	58	N 4064	O-Ring	O-ring	Joint torique	0.005	Ø 50 x 2	
			59	56141-060	Zylinder-Unterteil, 3. Stufe	Cylinder, lower, 3rd stage	Cylindre, partie inférieure du 3e étage	0.800		
					* Länge bei Bestellung angeben	* Indicate length when ordering	* Indiquer la longueur à la commande			

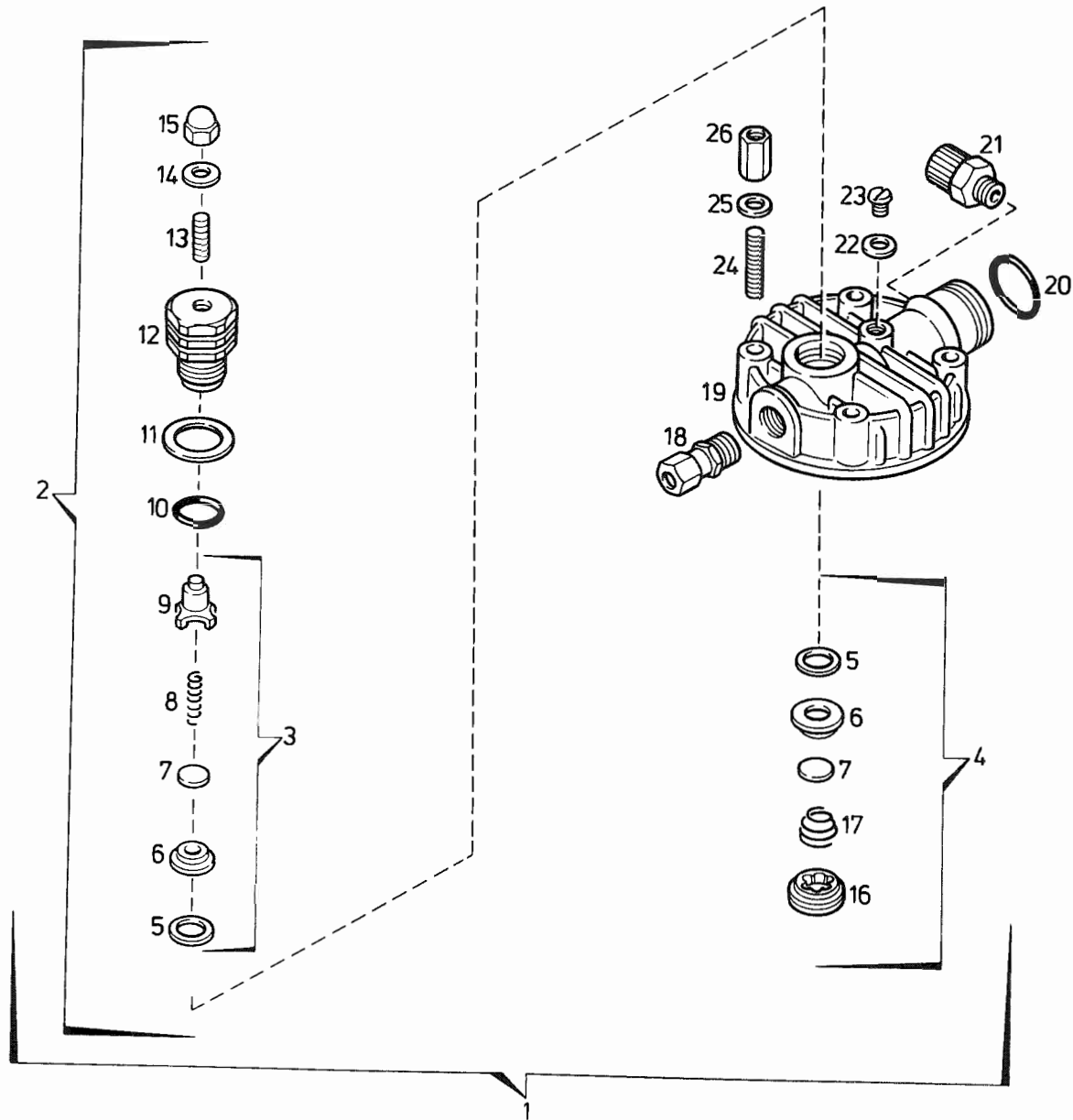



Ersatzteilsätze
Spare parts sets
Kits de pièces dét.

Bildtafel TU-2 Ventilkopf 1. Stufe
Figure TU-2 Valve head 1st stage
Planche TU-2 Culasse de 1er étage

Klasse Class Classe			Pos	Bestell-Nr. Part No. No. de cde.	Benennung	Designation	Dénomination	Gewicht Weight Poids (kg)	Abmessungen Dimensions Dimensions
0	2	5							
			1	014910-070	Ventilkopf 1. Stufe kpl.	Valve head assy 1st stage	Culasse de 1er étage cpl.	1.000	
			2	014583-080	Druckventil kpl.	Discharge valve assy	Clapet de refoulement cpl.	0.185	
	1		3	012840-080	Druckventileinsatz kpl.	Discharge valve insert assy	Garniture clapet de refoulement cpl.	0.028	
	1		4	012841-080	Saugventil	Intake valve	Clapet d'aspiration	0.035	
			5		Dichtung	Gasket	Joint	0.001	
			6		Ventilsitz	Valve seat	Siège de clapet	0.006	
			7		Ventilplatte	Valve plate	Plaque de clapet	0.002	
			8		Druckfeder	Spring	Ressort de pression	0.001	
			9		Druckventileinsatz	Discharge valve insert	Garniture clapet de refoulem.	0.018	
	1	1	3	N 3521	O-Ring	O-ring	Joint torique	0.005	Ø 21.82 x 3.53
			11	14332-080	Tellerfeder	Spring plate	Rondelle-ressort	0.003	
			12	14124-080	Verschraubung	Plug	Bouchon fileté	0.127	
			13	N 3520	Gewindestift	Stud	Vis sans tête	0.010	AM 8 x 25 DIN 913
	1	1	3	N 380	Dichtring	Gasket	Joint	0.001	C 8x14x1.5 DIN 7603
			15	N 84	Hutmutter	Acorn nut	Ecrou borgne	0.010	M 8 DIN 1587
			16		Ventilverschraubung	Inlet valve cover	Raccord fileté du clapet d'aspiration	0.026	
	1	1	3		Druckfeder	Spring	Ressort de pression	0.001	
			18	N 3418	Gerade Rohrverschraubung	Male connector	Raccord droit mâle	0.060	GE 12 PLR, Keg. 1/4"
			19	14911-070	Ventilkopf	Valve head	Culasse	0.400	
	1	1	2	N 1539	O-Ring	O-ring	Joint torique	0.005	Ø 30.3 x 2.4
			21	N 3737	Kunststoffverschraubung	Plastic connector	Raccord plastique	0.010	EG 8 x 1, R 1/4"
	1	1	2	N 2714	Dichtring	Gasket	Joint	0.001	C 6.5x9.5x1.5 DIN 7603
			23	N 730	Zylinderschraube	Screw	Vis à tête cylindrique	0.030	M 6 x 10 DIN 84
			24	N 3507	Stiftschraube	Stud	Goujon fileté	0.025	M 8 x 40
			25	N 58	Scheibe	Washer	Rondelle	0.005	Ø 8.4 DIN 125
			26	5290-080	Verlängerungsmutter	Hex. extension	Ecrou de rallonge	0.025	

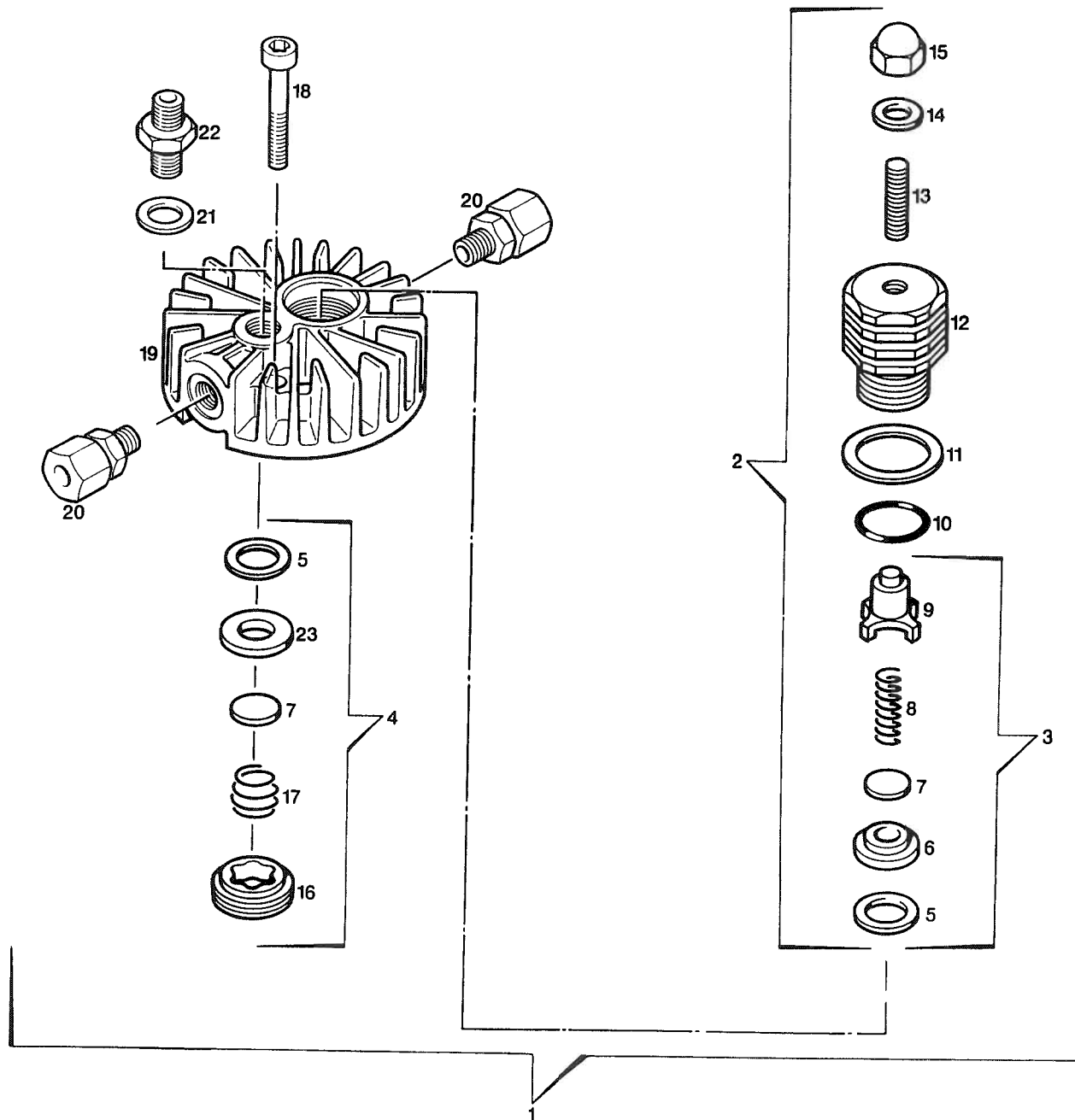



Ersatzteilsätze
Spare parts sets
Kits de pièces dét.

Bildtafel TU-3 Ventilkopf 2. Stufe
Figure TU-3 Valve head 2nd stage
Planche TU-3 Culasse de 2e étage

Klasse Class Classe			Pos.	Bestell-Nr Part No. No. de cde.	Benennung	Designation	Dénomination	Gewicht Weight Poids (kg)	Abmessungen Dimensions Dimensions
0	2	5							
			1	014085-070	Ventilkopf 2. Stufe kpl.	Valve head assy 2nd stage	Culasse cpl. de 2e. étage	0.850	
		1	2	014582-080	Druckventil kpl.	Discharge valve assy	Clapet de refoulement cpl.	0.185	
	1	3	3	012835-080	Druckventileinsatz kpl.	Discharge valve insert cpl.	Garniture clapet de refoulement cpl.	0.028	
		1	3	4	012836-080	Saugventil kpl.	Clapet d'aspiration cpl.		
			5		Dichtung	Gasket	Joint	0.001	
			6		Ventilsitz	Valve seat	Siège de clapet	0.006	
			7		Ventilplatte	Valve plate	Plaque de clapet	0.002	
			8		Druckfeder	Spring	Ressort de pression	0.001	
			9		Druckventileinsatz	Discharge valve insert	Garniture clapet de refoulem.	0.018	
1	1	3	10	N 3521	O-Ring	O-ring	Joint torique	0.005	Ø 21,82 x 3,53
			11	14332-080	Tellerfeder	Spring plate	Rondelle-ressort	0.003	
			12	14124-080	Verschraubung	Plug	Bouchon fileté	0.127	
			13	N 3520	Gewindestift	Stud	Vis sans tête	0.010	AM 8 x 25 DIN 913
1	1	3	14	N 380	Dichtring	Gasket	Joint	0.001	C 8x14x1,5 DIN 7603
			15	N 84	Hutmutter	Acorn nut	Ecrou borgne	0.010	M 8 DIN 1587
1	1	3	16		Saugventilverschraubung	Inlet valve cover	Bouchon fileté du clapet d'aspiration	0.878	
			17		Druckfeder	Inlet valve spring	Ressort de pression	0.001	
			18	N 503	Innensechskantschraube	Allen screw	Vis à six pans creux	0.018	M 8 x 35 DIN 912
			19	14123-070	Ventilkopf, 2. Stufe	Valve head, 2nd stage	Culasse de 2e étage	0.490	
			20	N 7838	Gerade Rohrverschraubung	Male connector	Raccord droit mâle	0.040	GE 12-LLR, R 1/4"
1	1	2	21	N 1316	Dichtring	Gasket	Joint	0.002	A 13 x 20 DIN 7603
			22	N 3504	Gerade Rohrverschraubung	Male connector	Raccord droit mâle	0.050	GE 8-SR, zyl.

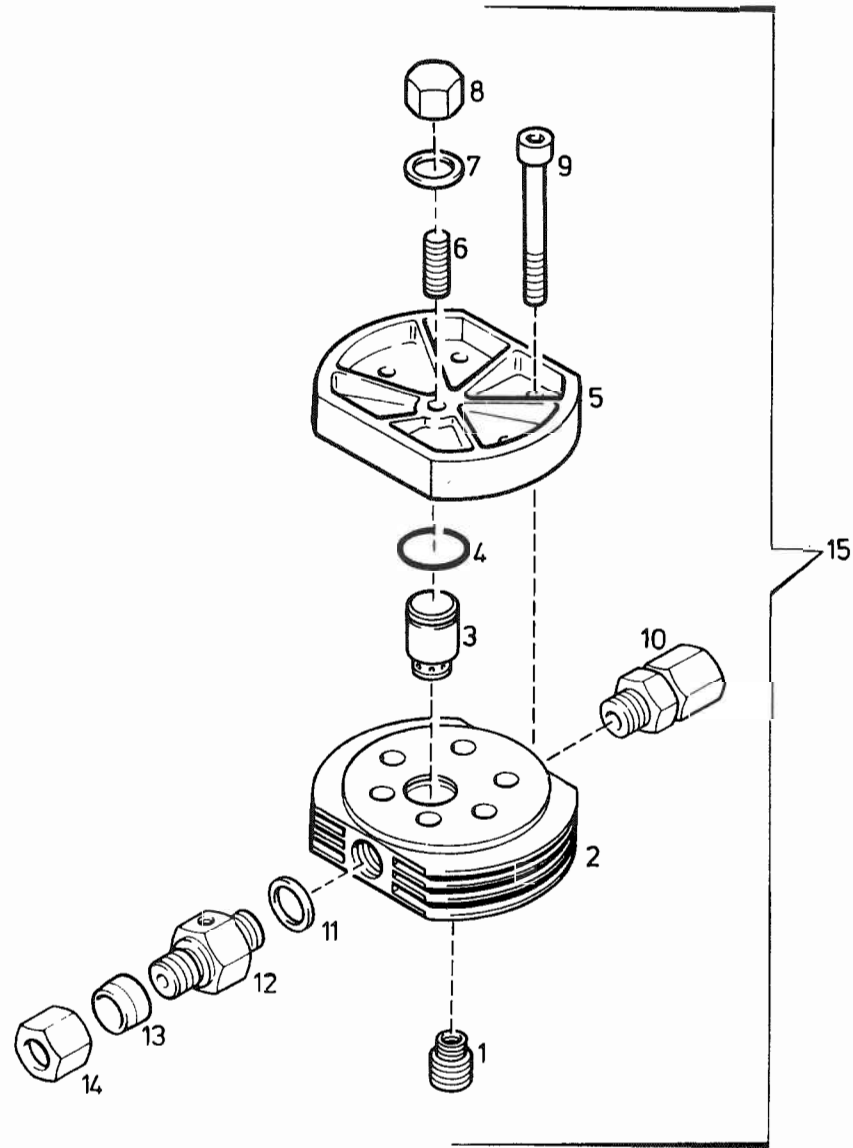



Ersatzteilsätze
Spare parts sets
Kits de pièces dét.

Bildtafel TU-4 Ventilkopf 3. Stufe
Figure TU-4 Valve head 3rd stage
Planche TU-4 Culasse de 3e étage

Klasse Class Classe			Pos.	Bestell-Nr. Part No. No. de cde.	Benennung	Designation	Dénomination	Gewicht Weight Poids (kg)	Abmessungen Dimensions Dimensions
0	2	5							
	1	3	1	07790-080	Saugventil	Intake valve	Clapet d'aspiration	0.007	
			2	14117-070	Ventilkopf	Valve head	Culasse	0.300	
	1	3	3	014121-080	Druckventil	Discharge valve	Clapet de refoulement	0.020	
1	1	3	4	N 2789	O-Ring	O-ring	Joint torique	0.005	Ø 15,6 x 1,78
			5	14118-070	Ventilkopfdeckel	Valve head cover	Couvercle de culasse	0.207	
			6	N 3624	Gewindestift	Stud	Vis sans tête	0.010	AM 8x1x25 DIN 913
1	1	3	7	N 3625	Dichtung	Gasket	Joint	0.001	A 8x14x1,5 DIN 7603
			8	N 3623	Hutmutter	Acorn nut	Ecrou borgne	0.010	M 8 x 1 DIN 917
			9	N 150	Innensechskantschraube	Allen screw	Vis à six pans creux	0.045	M 8 x 60 DIN 912
			10	N 7838	Gerade Rohrverschraubung	Male connector	Raccord droit mâle	0.040	GE 12 LLR, R 1/4"
1	1	3	11	N 1316	Dichtring	Gasket	Joint	0.001	A 13 x 20 DIN 7603
			12	57788-635	Zwischenstück	Adapter	Pièce intermédiaire	0.070	
			13	N 3609	Schneidring	Compression ring	Bague coupante	0.005	d 8-S
			14	N 3608	Überwurfmutter	Coupling nut	Ecrou-raccord	0.020	m 8-S
			15	057057-070	Ventilkopf 3. Stufe kpl.	Valve head assy. 3rd stage	Culasse cpl. de 3e étage	0.645	

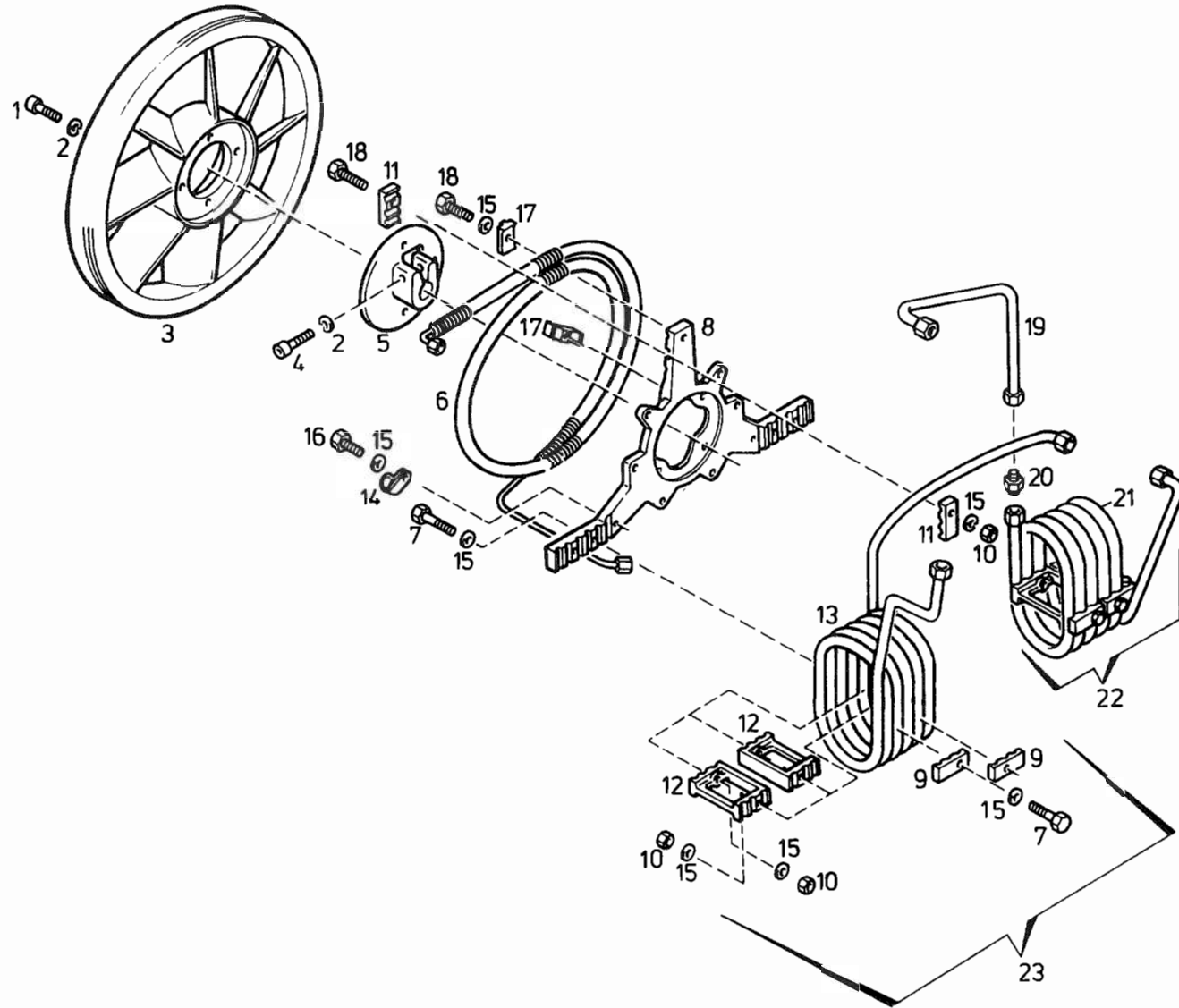



Ersatzteilsätze
Spare parts sets
Kits de pièces dét.

Bildtafel TU-5 Kühler und Ventilator
Figure TU-5 Cooler and fan
Planche TU-5 Refroidisseur et ventilateur

Klasse Class Classe			Pos.	Bestell-Nr. Part No. No. de cde.	Benennung	Designation	Dénomination	Gewicht Weight Poids (kg)	Abmessungen Dimensions Dimensions	
0	2	5								
			1	N 171	Innensechskantschraube	Allen screw	0.020	M 8 x 20	DIN 912'	
			2	N 108	Federring	Lock washer	0.005	A 8	DIN 127	
			3	13623-110	Ventilatorrad	Fan	3.190	Ø 400		
			4	N 1437	Innensechskantschraube	Allen screw	0.030	M 8 x 45	DIN 912	
			5	13666-110	Ventilatorradnabe	Fan hub	1.010			
			6	58310-500	Nachkühler	Aftercooler	0.875			
			7	N 3498	Sechskantschraube	Hex. screw	0.020	M 6 x 45	DIN 933	
			8	14998-860	Kühlrohrhalterung	Bracket for cooler	0.695			
			9	13662-500	Kühlrohrfixierstück	Fixing for cooler	0.020			
			10	N 1042	Sechskantmutter, sebsts.	Hex. nut, self-locking	0.005	NM 6	DIN 980	
			11	14564-500	Kühlrohrfixierstück	Fixing for cooler	0.020			
			12	13663-500	Zwischenstück	Intermediate piece	0.065			
			13		Kühlrohrspirale 2. Stufe	Cooler 2nd stage	0.550			
			14	14370-500	Rohrschelle	Pipe clamp	0.017			
			15	N 102	Scheibe	Washer	0.005	Ø 6.4	DIN 125	
			16	N 101	Sechskantschraube	Hex. screw	0.010	M 6 x 20	DIN 933	
			17	14139-500	Klemmstück	Clamp	0.017			
			18	N 3531	Sechskantschraube	Hex. screw	0.010	M 6 x 40	DIN 933	
			19	14901-500	Verbindungsleitung	Connecting tube	0.125			
			20	N 3464	Gerade Rohrverschraubung	Male connector	0.042	G 12-LL		
			21		Kühlrohrspirale 1. Stufe	Cooler 1st stage	0.465			
			22	014624-500	Zwischenkühler 1. Stufe	Intercooler 1 st stage	0.535			
			23	058991-500	Zwischenkühler 2. Stufe	Intercooler 2nd stage	0.720			

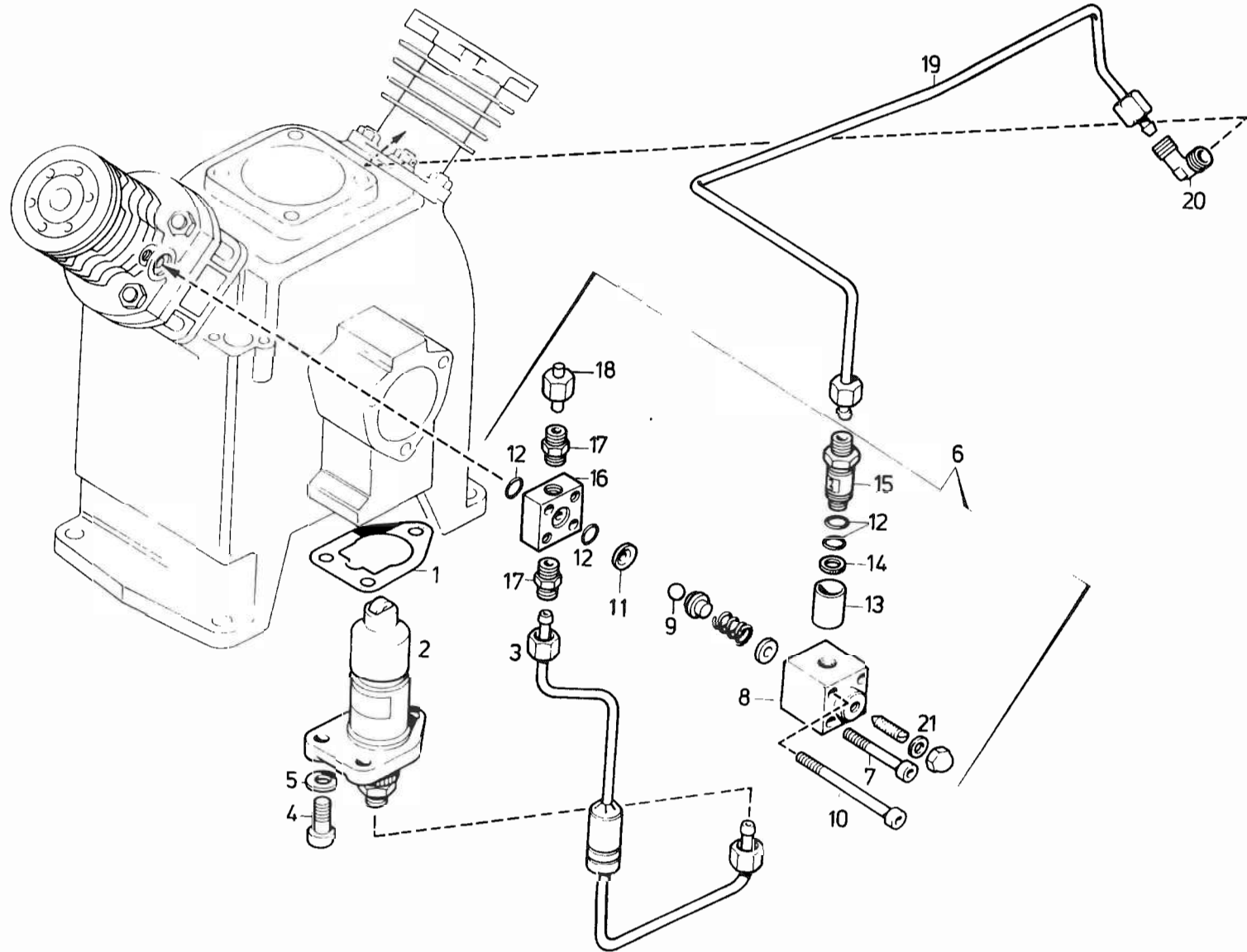



Ersatzteilsätze
Spare parts sets
Kits de pièces det.

Bildtafel TU-6 Öldruckschmierung
Figure TU-6 Lubrication
Planche TU-6 Lubrification

Klasse Class Classe			Pos.	Bestell-Nr Part No. No. de cde.	Benennung	Designation	Dénomination	Gewicht Weight Poids (kg)	Abmessungen Dimensions Dimensions			
0	2	5										
1	1	1	1	2010-90	Dichtung	Gasket	Joint	0.001	..			
		1	2	N 83	Ölpumpe	Oil pump	Pompe à huile	0.810				
		1	3	57150-650	Druckölleitung	Oil supply tube	Conduite d'huile sous press.	0.105				
			4	N 61	Innensechskantschraube	Allen screw	Vis à six pans creux	0.015	M 8 x 25	DIN 912		
			5	N 58	Scheibe	Washer	Rondelle	0.005	Ø 8.4	DIN 125		
			1	6	058138-341	Öldruckregulierventil	Oil pressure regulating valve	Régulateur de la pression d'huile	0.280			
			7	N 781	Innensechskantschraube	Allen screw	Vis à six pans creux	0.015	M 6 x 60	DIN 912		
			8	58102-341	Öldruckregulierventilgehäuse	Housing for oil pressure regulating valve	Corps du régulateur de la pression d'huile	0.120				
			1	2	9	N 2768	Kugel	Ball	0.005	Ø 8		
				10		N 3407	Innensechskantschraube	Allen screw	0.020	M 6 x 80	DIN 912	
			1	2	11	58119-341	Kugelventilsitzplatte	Seat of ball valve	0.010			
		4	2	2	12	N 7091	O-Ring	O-ring	0.001	Ø 9,25 x 1,78		
			1	2	13	56302-635	Ölschauglas	Oil gauge glass	Regard du niveau d'huile	0.003		
		1	1	1	14	N 4051	Dichtring	Gasket	Joint	0.005	A 10 x 15	DIN 7603
					15	56301-635	Ölkontrollverschraubung	Oil level check union	Raccord de contrôle du niveau d'huile	0.010		
					16	57132-341	Öldruckregulierventilflansch	Flange for oil pressure regulating valve	Bride du régulateur de la pression d'huile	0.048		
					17	N 4140	Gerade Rohrverschraubung	Male connector	Raccord droit mâle	0.013	GE 6-LLR ed	
					18	N 4530	Verschlußstopfen	Plug	Bouchon fileté	0.015		
					19	57151-650	Ölrücklaufleitung	Oil return tube	Conduite de retour d'huile			
					20	N 1057	Winkel-Rohrverschraubung	Male elbow	Raccord coudé mâle	0.035	WE 6-LR	
					21	N 380	Dichtring	Gasket	Joint	0.001	8 x 14 x 1.5	

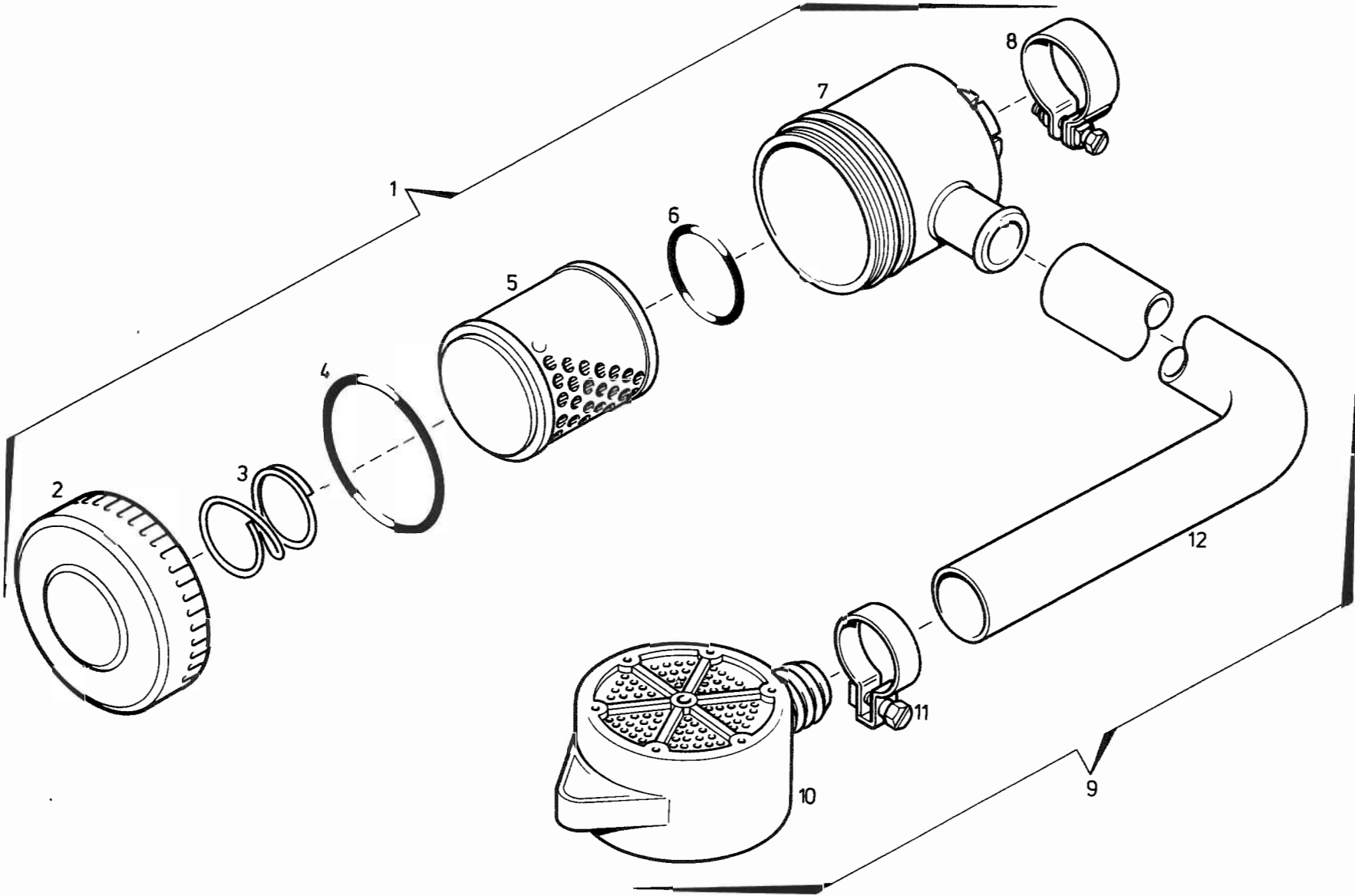



Ersatzteilsätze
Spare parts sets
Kits de pièces dét.

Bildtafel TU-7 Ansaugfilter mit Ansaugschlauch
Figure TU-7 Intake filter with intake hose
Planche TU-7 Filtre d'aspiration avec tuyau d'aspiration

Klasse Class Classe			Pos.	Bestell-Nr. Part No. No. de cde.	Benennung	Designation	Dénomination	Gewicht Weight Poids (kg)	Abmessungen Dimensions Dimensions
0	2	5							
1	1	1	1	013758-400	Ansaugfilter	Intake filter assy	Filtre d'aspiration	0.340	Ø 75 x 3 Ø 35 x 5 Nr. 38, Ø 28-30
			2	12771-400	Ansaugfilterdeckel	Intake filter cover	Couvercle du filtre d'aspir.	0.080	
			3	10528-640	Druckfeder	Spring	Ressort de pression	0.008	
			4	N 4451	O-Ring	O-ring	Joint torique	0.010	
			5	N 70	Filtereinsatz	Filter element	Élément filtrant	0.070	
			6	13757-090	O-Ring	O-ring	Joint torique	0.005	
			7	12770-400	Ansaugfiltergehäuse	Intake filter housing	Corps du filtre d'aspir.	0.150	
			8	N 3374	Rohrschelle	Clamp	Collier pour tuyaux	0.020	
			9	014539-400	Ansaugschlauch kpl. mit Filter	Intake hose assy with filter	Tuyau d'aspir. avec filtre	0.800	
			10	057691-400	Vorfilter	Pre-filter	Premier filtre	0.115	
			11	N 2011	Schlauchklemme	Hose clamp	Collier pour tuyaux	0.005	
			12	N 1005	Ansaugschlauch	Intake hose	Tuyau d'aspiration	0.680	

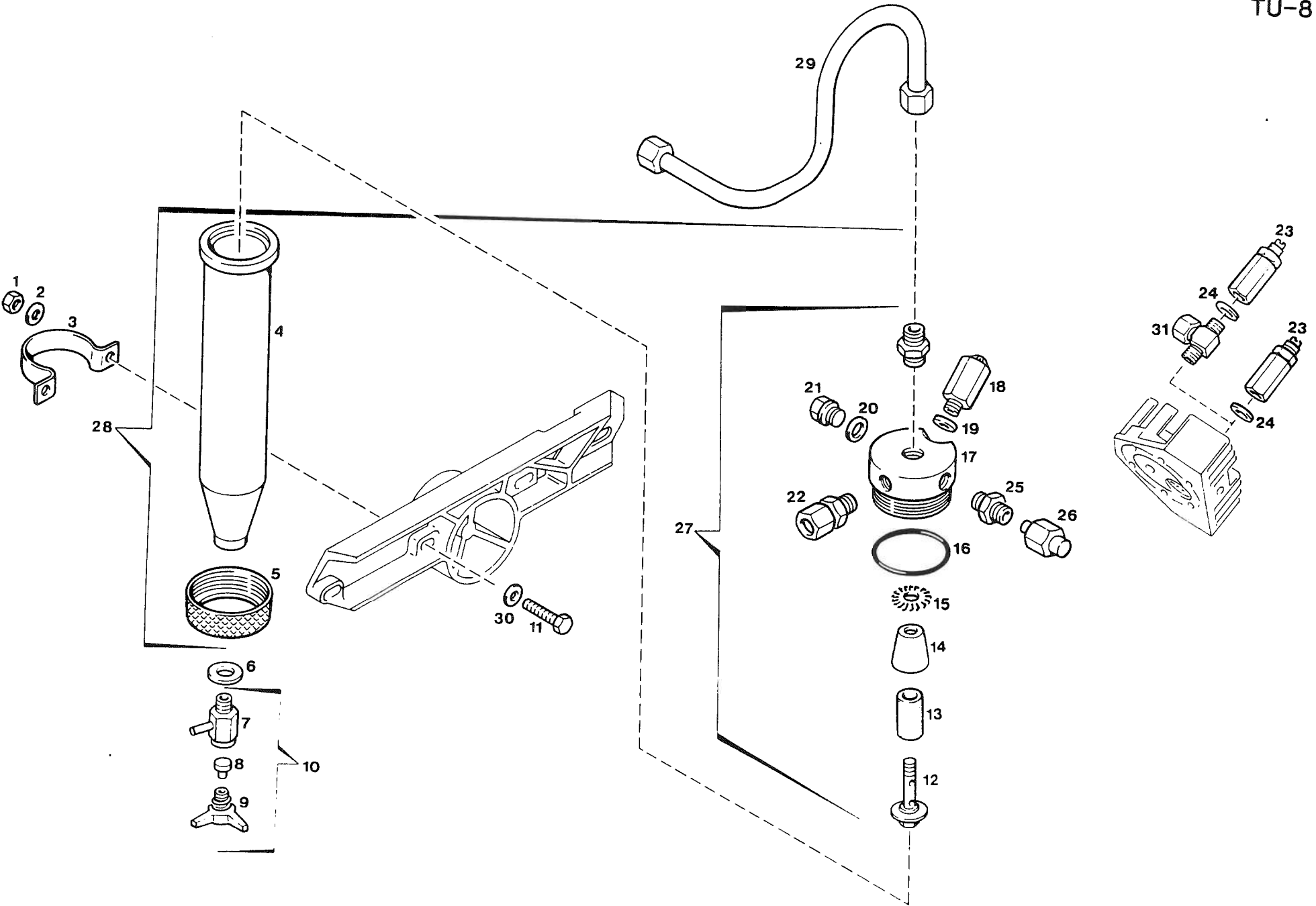



Ersatzteilsätze
Spare parts sets
Kits de pièces det.

Bildtafel TU-8 Zwischenfilter
Figure TU-8 Interfilter
Planche TU-8 Séparateur intermédiaire

Klasse Class Classe			Pos.	Bestell-Nr Part No. No. de cde.	Benennung	Designation	Dénomination	Gewicht Weight Poids (kg)	Abmessungen Dimensions Dimensions	
0	2	5								
			1	N 57	Sechskantmutter	Hex. nut	Ecrou hexagonal	0,008	M 8	DIN 934
			2	N 2862	Scheibe	Washer	Rondelle	0,007	Ø 8,4	DIN 7349
			3	14368-655	Rohrschelle	Clamp	Collier pour tuyaux	0,125		
			4	14150-430	Filtergehäuse	Filter housing	Corps de séparateur	0,300		
			5	13937-430	Überwurfnutter	Threaded collar	Bague fileté	0,130		
1	1	1	6	N 1316	Dichtung	Gasket	Joint	0,005	A 13 x 20	DIN 7603
			7	2371-635	Ablaßhahnkörper	Drain tap housing	Corps de robinet de purge	0,055		
1	2	5	8	13283-090	Dichtung	Gasket	Joint	0,001		
			9	055888-635	Knebelschraube mit Sicherungsf.	Tap screw with spring	Robinet avec ressort	0,020		
			10	011430-635	Kondensatablaßhahn	Condensate drain tap	Robinet de purge cpl.	0,075		
			11	N 89	Sechskantschraube	Hex. screw	Vis hexagonale	0,020	M 8 x 30	DIN 933
			12	12786-430	Mittelschraube	Screw	Vis centrale	0,006		
	1	2	13	N 2726	Filtereinsatz	Filter element	Elément filtrant	0,015		
			14	12785-430	Pralltrichter	Baffle cone	Cône de dispersion	0,003		
			15	12784-430	Verteilerblech	Vortex plate	Diffuseur	0,001		
1	1	1	16	N 3556	O-Ring	O-ring	Joint torique	0,005	Ø 45 x 2	
			17	13930-430	Filterkopf	Filter head	Chapeau du séparateur	0,185		
			18	011656-340	Sicherheitsventil 2. Stufe	Safety valve 2nd stage	Soupape de sûreté, 2e étage	0,058	50 bar	
1	1	1	19	4479-090	Dichtung	Gasket	Joint	0,001		
			20	N 4051	Dichtung	Gasket	Joint	0,005	A 10 x 15	DIN 7603
			21	N 3459	Verschlußschraube	Plug	Bouchon fileté	0,060	R 1/8"	DIN 910
			22	N 7838	Gerade Rohrverschraubung	Male connector	Raccord droit mâle	0,040	GE 12 LLR, R 1/4"	
			23	010670-340	Sicherheitsventil 1. Stufe	Safety valve 1st stage	Soupape de sûreté, 1er étage	0,065	8 bar	
1	1	1	24	8264-090	Dichtung	Gasket	Joint	0,001		
			25	N 1051	Gerade Rohrverschraubung	Male connector	Raccord droit mâle	0,025	GE 6-LR	
			26	N 4530	Verschlußstopfen	Plug	Bouchon fileté	0,015		
			27	014151-430	Filterkopf kpl.	Filter head assy	Chapeau du séparateur cpl.	0,350		
			28	014427-430	Zwischenfilter kpl.	Interfilter assy	Séparateur intermédiaire cpl.	0,820		
			29	58249-500	Verbindungsleitung	Connecting tube	Conduite de connexion	0,072		
			30	N 58	Scheibe	Washer	Rondelle	0,005	Ø 8,4	DIN 125
			31	N 3304	Einstellbare L-Verschraubung	Adjustable male run Tee	Raccord en T renversé orient.	0,087	evL 6-PS	

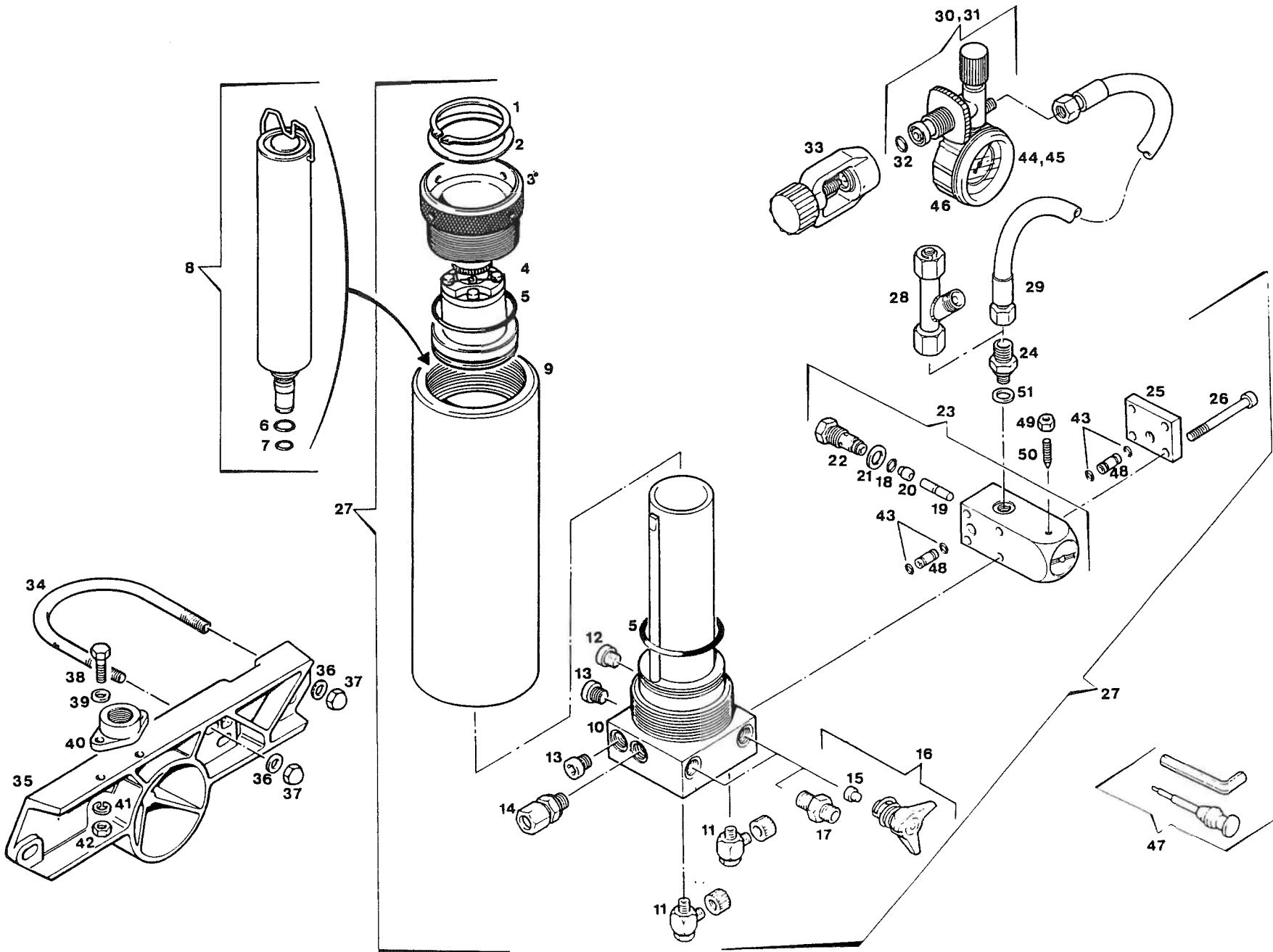



Ersatzteilsätze
Spare parts sets
Kits de pièces dét.

Bildtafel TU-9 Filtersystem P21 mit Fülleinrichtung
Figure TU-9 Filter system P21 with filling device
Planche TU-9 Système de filtration P21 avec dispositif de remplissage

Klasse Class Classe			Pos.	Bestell-Nr. Part No. No. de cde.	Benennung	Designation	Dénomination	Gewicht Weight Poids (kg)	Abmessungen Dimensions Dimensions
0	2	5							
	1	1	1	N 15598	Sicherungsring	Circlip	Circlip	0.005	55 x 2 DIN 471
	1	1	2	63438-410	Gleitring	Slide ring	Anneau de glissement	0.010	
			3	068920-410	Verschraubung*	Plug*	Chapeau de filtre*		
			4	061114-340	Sicherheitsventil**	Safety valve**	Soupape de sûreté**	0.500	100 - 350 bar
2	2	2	5	N 4586	O-Ring	O-ring	Joint torique	0.050	Ø 59,92 x 3,53
1	1	1	6	N 4566	O-Ring	O-ring	Joint torique	0.050	Ø 9,19 x 2,62
1	1	1	7	N 3824	O-Ring	O-ring	Joint torique	0.050	Ø 7,59 x 2,62
			8	057679-410	Triplexpatrone	Triplex cartridge	Cartouche triplex	0.300	
			9	068920-410	Filtergehäuse*	Filter housing*	Corps de filtre*		
			10	068920-410	Filterboden*	Filter bottom*	Fond de filtre*		
			11	N 16334	L-Schnellverschraubung	Male run T connector	Raccord en T renversé		
			12	N 16954	Verschlußschraube	Plug	Bouchon fileté	0.015	vsti R 1/8" -ed
			13	N 16394	Verschlußschraube	Plug	Bouchon fileté	0.020	vsti R 1/4" -ed
			14	N 4687	Gerade Rohrverschraubung	Male connector	Raccord droit mâle	0.055	GE 8 PSR -ed
1	3	5	15	64498-635	Dichtung	Gasket	Joint	0.005	
			16	065500-635	Knebelschraube kpl.	Condensate drain tap assy.	Robinet de purge cpl.	0.090	
			17	63666-635	Gerade Rohrverschraubung	Male connector	Raccord droit mâle		
1	1	1	18	N 16554	O-Ring	O-ring	Joint torique		Ø 6 x 1,5
	1	2	19	066112-341	Druckstift kpl.	Pressure pin assy.	Cheville de pression cpl.		
	1	2	20	57735-341	Ventilkolben	Valve piston	Piston de clapet	0.040	
1	2	2	21	N 4602	USIT-Ring	USIT-ring	Joint	0.020	U 14-18.7-1.5
		1	22	57741-341	Druckhalteventilsitz	Pressure maintaining valve seat	Siège du clapet de maintien de pression	0.025	
		1	23	058037-341	Druckhalteventil	Pressure maintaining valve	Clapet de maintien de press.	0.040	
			24	65363-635	UNIMAM-Verschraubung	Connector	Raccord		
			25	57937-341	Abschlußdeckel	Cover	Obtuteur		
			26	N 781	Innensechskantschraube	Allen screw	Vis à six pans creux	0.015	M 6 x 60 DIN 912
			27	062211-410	Zentralfilter o. Patrone	Central filter assy w/o cartridge	Filtre central sans cartouche		
			28	014532-635	Verteiler	Distributor	Distributeur		
		1	29	N 2817	Füllschlauch	Filling hose	Tuyau de remplissage	0.600	NW 6 x 1 m lg.
		1	30	060483-635	Füllventil	Filling valve	Robinet de remplissage	0.740	200 bar
		1	31	060482-635	Füllventil	Filling valve	Robinet de remplissage	0.740	300 bar
1	1	1	32	N 638	O-Ring	O-ring	Joint torique	0.005	Ø 11 x 2,5
			33	08487-635	Internat. Füllanschlußbügel	International connection	Raccord international		200 bar
			34	58165-635	Befestigungsbügel	U-bolt	Etrier de fixation		
			35	58159-860	Filterhalterung	Filter mounting	Support de filtre		
			36	N 2862	Scheibe	Washer	Rondelle	0.002	Ø 8,4 DIN 7349
			37	N 84	Hutmutter	Acorn nut	Ecrou borgne	0.013	M 8 DIN 1587

* Pos. 3, 9, 10 nur zusammen
lieferbar
** Einstelldruck bei Bestellung
angeben

* Pos. 3, 9, 10 available
as set only
** Indicate adjusted
pressure when ordering

* Les pos. 3, 9, 10 ne sont
livrées qu'ensemble
** Indiquer la pression
d'ajustage à la commande

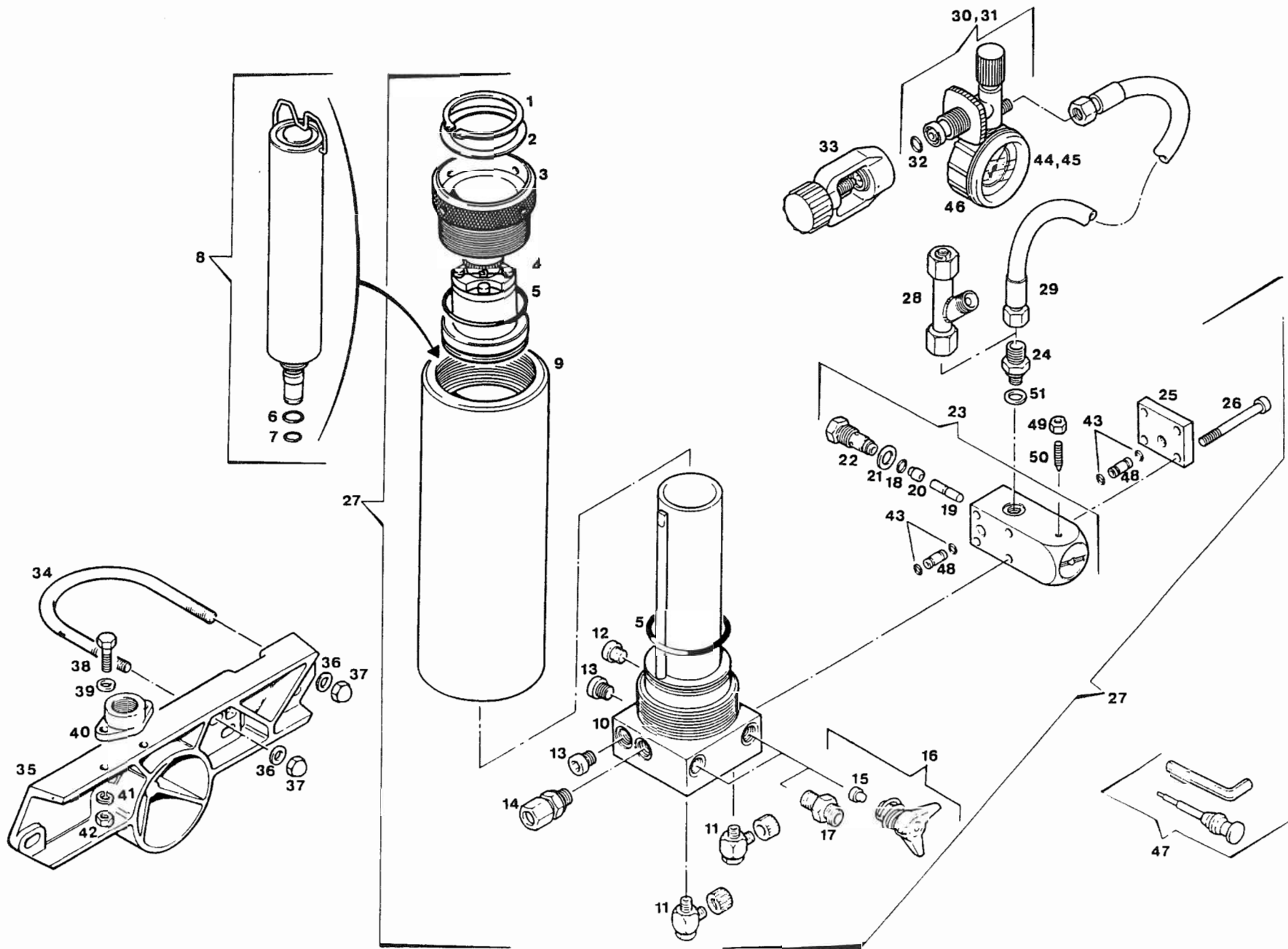



Ersatzteilsätze
Spare parts sets
Kits de pièces dét.

Bildtafel TU-9 Filtersystem P21 mit Fülleinrichtung
Figure TU-9 Filter system P21 with filling device
Planche TU-9 Système de filtration P21 avec dispositif de remplissage

Klasse Class Classe			Pos.	Bestell-Nr Part No. No. de cde.	Benennung	Designation	Dénomination	Gewicht Weight Poids (kg)	Abmessungen Dimensions Dimensions			
0	2	5										
4	4	4	38	N 2900	Sechskantschraube	Hex. screw	Vis hexagonale	0.005	M 6 x 25	DIN 933		
			39	N 102	Scheibe	Washer	Rondelle	0.010	B 6,4	DIN 125		
			40	12731-635	Füllventilbefestigung	Filling valve mounting	Fixation soupape de rempliss.					
			41	N 100	Federring	Lock washer	Rondelle élastique	0.001	A 6	DIN 127		
			42	N 287	Sechskantmutter	Hex. nut	Ecrou hexagonal	0.005	M 6	DIN 934		
			43	N 16591	O-Ring	O-ring	Joint torique	0.005	Ø 5 x 1,5			
			44	N 1315	Manometer*	Pressure gauge*	Manomètre*	0.200	200 bar			
			45	N 4101	Manometer*	Pressure gauge*	Manomètre*	0.200	300 bar			
			46	N 2876	Schutzkappe	Protection cap	Capot de protection	0.036				
			47	067458-645	Werkzeugsatz f. Knebelschraube	Tool set for petcock handle	Jeu d'outils pour robinet de purge					
						48	57904-410	Verbindungsrohr	Connection pipe			
						49	N 3877	Sechskantmutter	Hex. nut		NM 4	DIN 980
						50	N 4465	Gewindestift	Stud	0.001	M4 x 10	DIN 553
			1	1	1	51	N17071	Dichtring	Gasket	0.001	A 13 x 19 x 2	
				1	4		060399-635	Reparatursatz f. Füllventil	Repair kit for filling valve	0.100		

* Je nach Betriebsdruck

* Acc. to operating pressure

* Selon pression de service

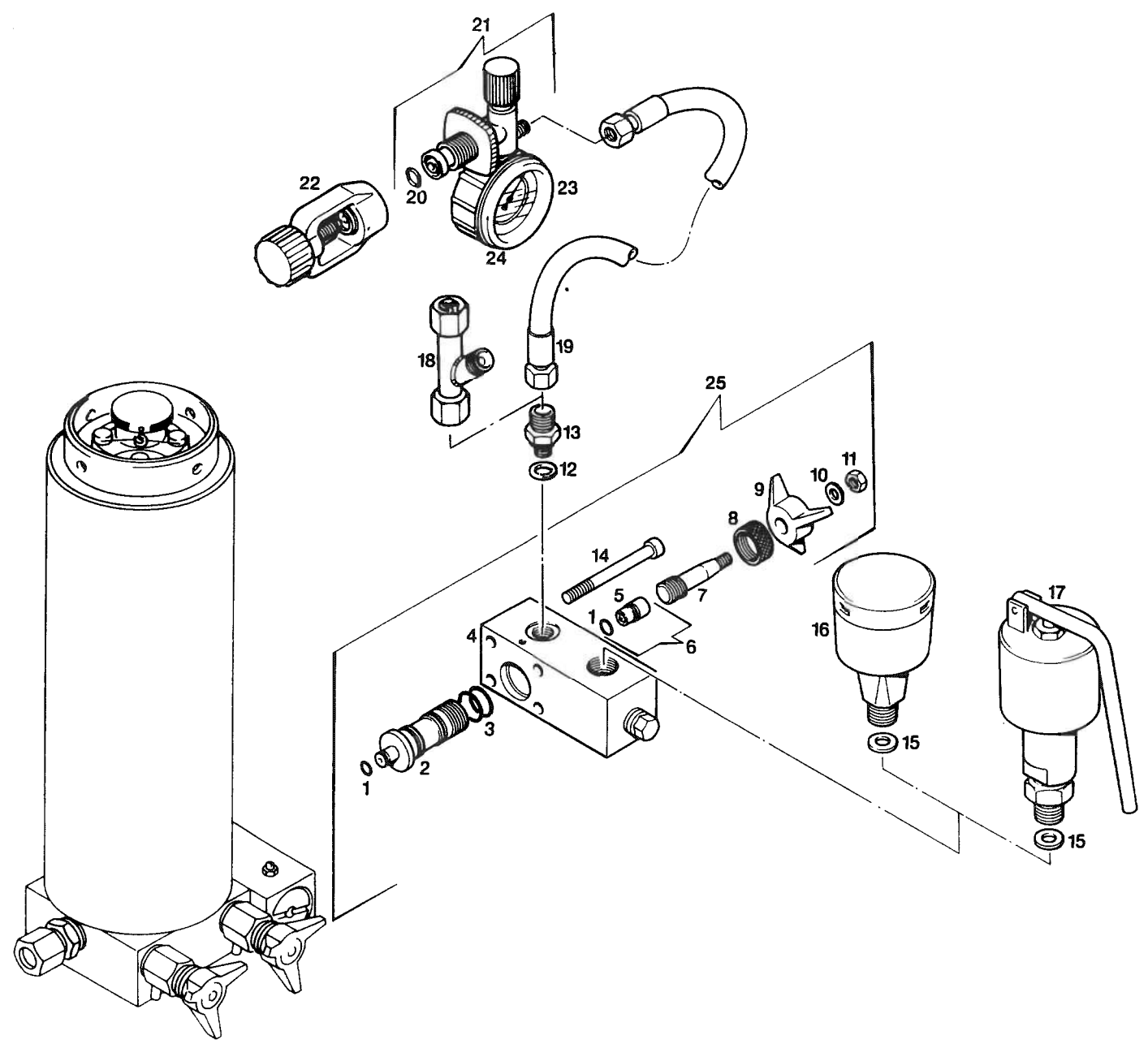



Ersatzteilsatz
Spare parts sets
Kits de pieces det.

Bildtafel TU-10 Umschalteinrichtung PN 200/PN 300 für Filtersystem P21
Figure TU-10 Change over device 3200/4700 psi for filter system P21
Planche TU-10 Dispositif sélecteur PN 200/PN 300 pour système de filtration P21

Klasse Class Classe			Pos.	Bestell-Nr. Part No. No. de cde.	Benennung	Designation	Dénomination	Gewicht Weight Poids (kg)	Abmessungen Dimensions Dimensions
0	2	5							
1	1	2	1	N 16591	O-Ring	O-ring	Joint torique	0,005	∅ 5 x 1,5
			2	58030-635	Spindelaufnahme	Spindle carrier	Porte broche	0.054	
2	2	4	3	N 3405	O-Ring	O-ring	Joint torique	0.005	∅ 12,42 x 1,78
			4	57701-635	Umschaltleiste	Switch over block	Bloc sélecteur	0.254	
			5	58178-635	Spindelkolben	Spindle piston	Piston de broche		
	1	2	6	058229-635	Spindelkolben kpl.	Spindle piston assy.	Piston de broche cpl.	0.005	
			7	58223-635	Spindel	Spindle	Broche		
			8	58032-635	Sicherungsmutter	Lock nut	Contre-écrou	0.010	
	1	2	9	58228-635	Knebelgriff	Tap screw	Robinet	0.008	
			10	N 2949	Scheibe	Washer	Rondelle	0.001	B 5,3 DIN 125
			11	N 2488	Sechskantmutter, selbsts.	Hex. nut, self-locking	Ecrou hex., auto-freinant	0.002	NM 5 DIN 980
1	1	2	12	N 17071	Dichtring	Gasket	Joint	0.001	A 13 x 19 x 2
			13	65363-635	UNIMAM-Verschraubung	Connector	Raccord		
			14	N 3407	Innensechskantschraube	Allen screw	Vis à six pans creux	0,040	M 6 x 80 DIN 912
1	1	2	15	4479-090	Dichtung	Gasket	Joint	0.001	
		1	16	03063-340	Sicherheitsventil*	Safety valve*	Soupape de sûreté*	0.310	200 bar
		1	17	013497-340	Sicherheitsventil*	Safety valve*	Soupape de sûreté*	0.800	200 bar
			18	014532-635	Verteiler	Distributor	Distributeur	0.240	
			19	N 2817	Füllschlauch	Filling hose	Tuyau de remplissage	0.600	NW 6 x 1 m lg.
1	1	2	20	N 638	O-Ring	O-ring	Joint torique	0.005	∅ 11 x 2,5
		1	21	060483-635	Füllventil	Filling valve	Soupape de remplissage	0.550	200 bar
			22	08487-635	Internat. Füllanschlußbügel	International connection	Raccord international		200 bar
	1	1	23	N 1315	Manometer	Pressure gauge	Manomètre	0.200	200 bar
	1	1	24	N 2876	Schutzkappe	Protection cap	Capot de protection	0.036	

* Einstelldruck bei Bestellung angeben

* Indicate adjusted pressure on order

* Indiquer la pression de réglage à la commande

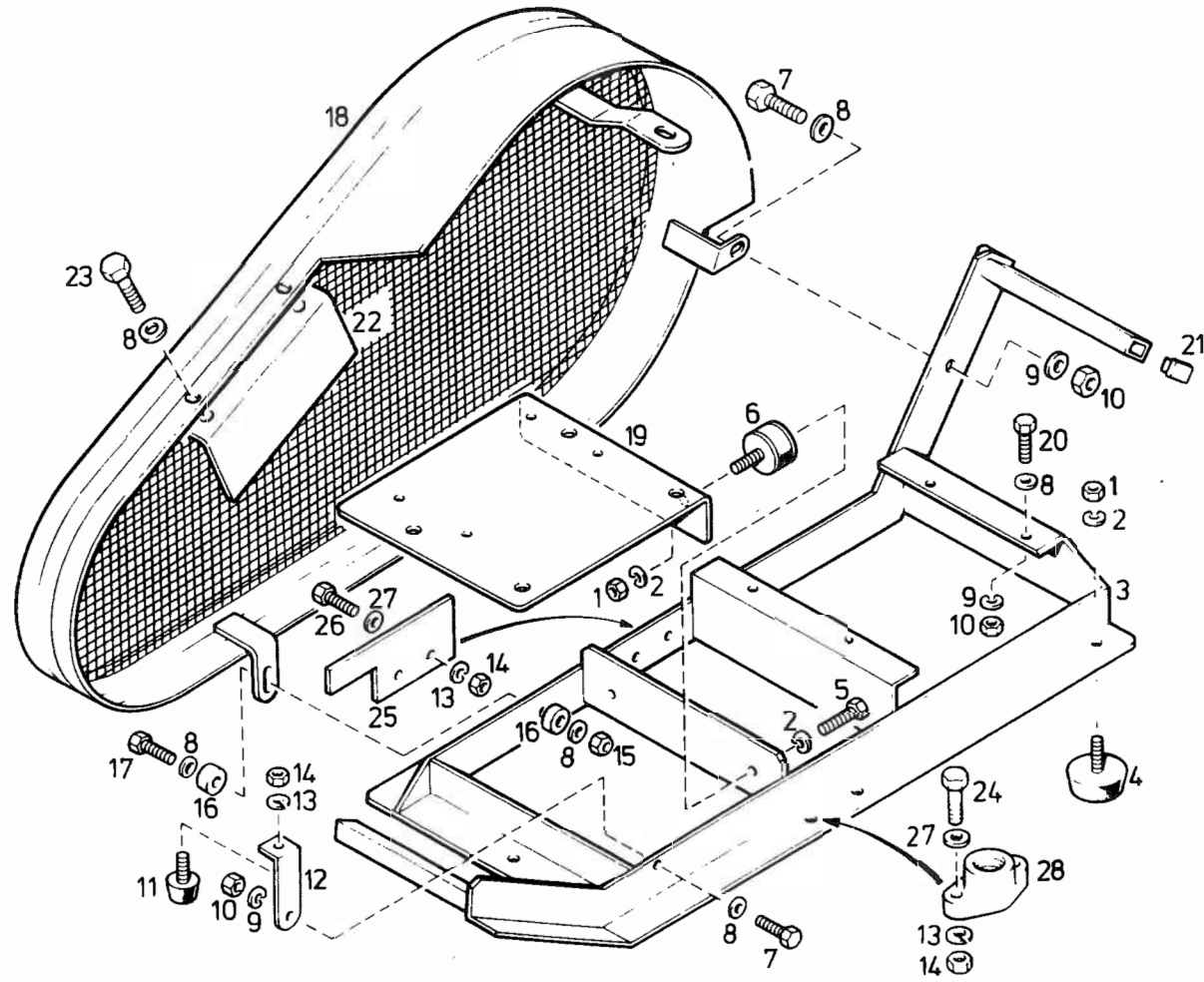



Ersatzteilsätze
Spare parts sets
Kits de pièces dét.

Bildtafel TU-11 Rahmen
Figure TU-11 Frame
Planche TU-11 Cadre

Klasse Class Classe			Pos	Bestell-Nr Part No. No de cde.	Benennung	Designation	Dénomination	Gewicht Weight Poids (kg)	Abmessungen Dimensions Dimensions	
0	2	5								
			1	N 177	Sechskantmutter	Hex. nut	Ecrou hexagonal	0.015	M 10	DIN 934
			2	N 176	Federring	Lock washer	Rondelle élastique	0.005	A 10	DIN 127
			3	14344-760	Rahmen	Frame	Cadre		U2B, U3E, U3W / -H	
			4	N 1547	Schwingmetall	Vibration isolator	Amortisseur	0.085	Ø 50 x 15	
			5	N 570	Sechskantschraube	Hex. screw	Vis hexagonale	0.020	M 10 x 16	DIN 933
			6	N 1649	Schwingmetall	Vibration isolator	Amortisseur	0.125	Ø 50 x 20	
			7	N 198	Sechskantschraube	Hex. screw	Vis hexagonale	0.018	M 8 x 20	DIN 933
			8	N 58	Scheibe	Washer	Rondelle	0.005	Ø 8,4	
			9	N 108	Federring	Lock washer	Rondelle élastique	0.005	A 8	DIN 127
			10	N 57	Sechskantmutter	Hex. nut	Ecrou hexagonal	0.008	M 8	DIN 934
			11	N 1899	Anschlagpuffer	Vibration isolator	Amortisseur	0.015	U2B, /-H	
			12	14450-655	Anschlagwinkel	Stop angle	Equerre de butée	0.050	U2B, /-H	
			13	N 100	Federring	Lock washer	Rondelle élastique	0.001	A 6	DIN 127
			14	N 287	Sechskantmutter	Hex. nut	Ecrou hexagonal	0.005	M 6	DIN 934
			15	N 370	Sechskantmutter, selbsts.	Hex. nut, self-locking	Ecrou hex., auto-freinant	0.009	NM 8	
			16	13489-864	Gummscheibe	Rubber washer	Rondelle en caoutchouc		Ø 8 x 20	
			17	N 88	Sechskantschraube	Hex. screw	Vis hexagonale	0.016	M 8 x 25	DIN 933
			18	14401-620	Riemenschutz	Belt guard	Protection de courroie	2.200		
			19	14349-615	Motorwippe	Pedestal	Moto-interrupteur à bascule	1.460	U2B, U3E, U3W, /-H	
			20	N 89	Sechskantschraube	Hex. screw	Vis hexagonale	0.020	M 8 x 30	DIN 933
			21	N 3526	Plastikkappe	Plastic cap	Bouchon plastique		20 x 20 x 2	
			22	14446-620	Abdeckplatte	Cover plate	Plaque de recouvrement	0.300	U3E, U3W, /-H	
			23	N 542	Sechskantschraube	Hex. screw	Vis hexagonale	0.015	M 8 x 16	DIN 933
			24	N 680	Sechskantschraube	Hex. screw	Vis hexagonale	0.005	M 6 x 35	DIN 933
			25	64911-620	Abdeckplatte	Cover plate	Plaque de recouvrement			
			26	N 53	Sechskantschraube	Hex. screw	Vis hexagonale	0.005	M 6 x 16	DIN 933
			27	N 102	Scheibe	Washer	Rondelle	0.010	Ø 6,4	
			28	12731-635	Füllventilbefestigung	Filling valve mounting	Fixation robinet de rempliss.	0.025		

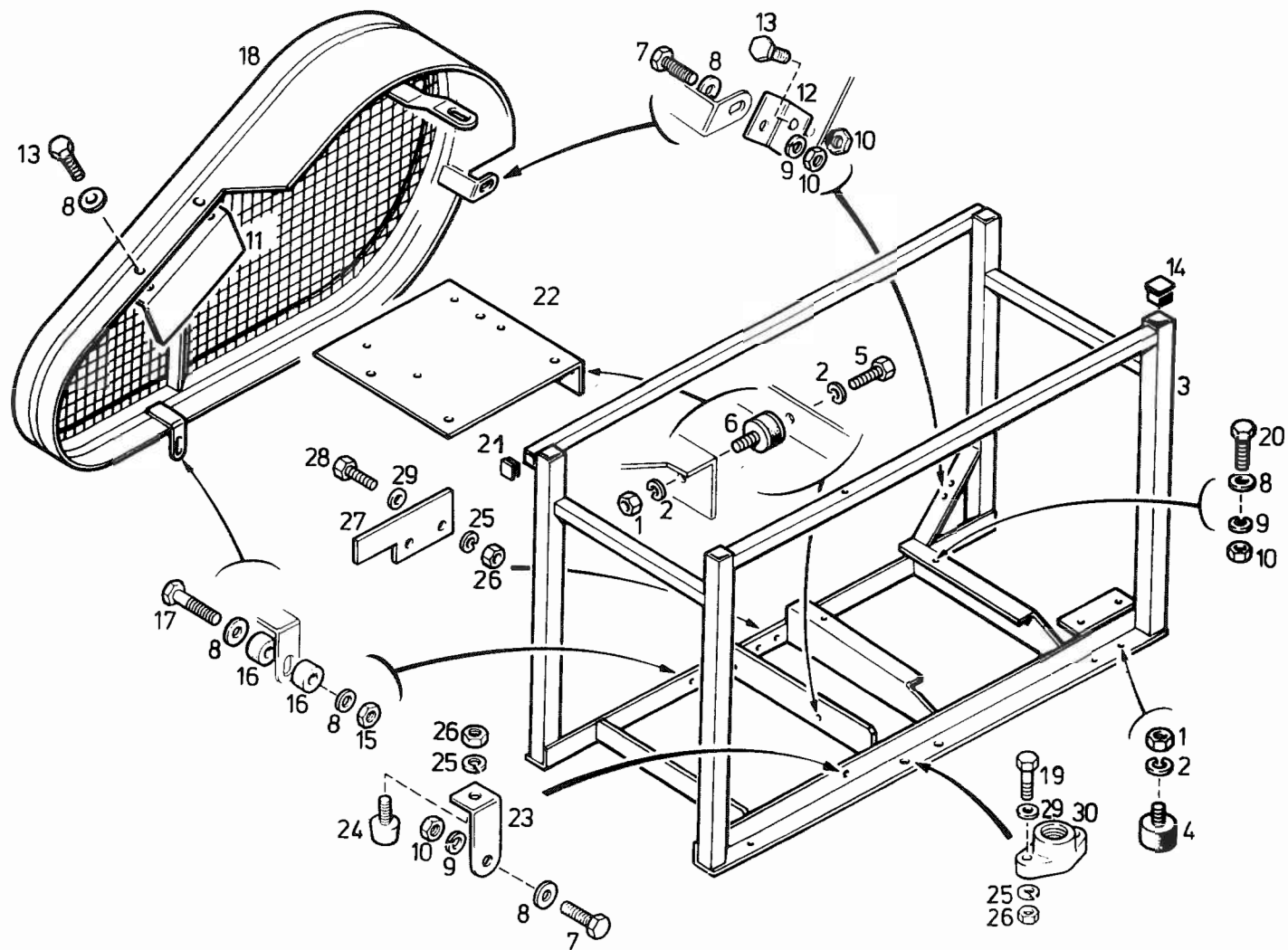



Ersatzteilsätze
Spare parts sets
Kits de pieces dét.

Bildtafel TU-12 Sturzrahmen
Figuré TU-12 Protection frame
Planche TU-12 Cadre de protection

Klasse Class Classe			Pos.	Bestell-Nr Part No. No. de cde.	Benennung	Designation	Dénomination	Gewicht Weight Poids (kg)	Abmessungen Dimensions Dimensions	
0	2	5								
			1	N 177	Sechskantmutter	Hex. nut	Ecrou hexagonal	0.015	M 10	DIN 934
			2	N 176	Federring	Lock washer	Rondelle élastique	0.005	A 10	DIN 127
			3	14637-760	Rahmen	Frame	Cadre	15.00		
		4	4	N 1547	Schwingmetall	Vibration isolator	A amortisseur	0.085	Ø 50 x 15	
			5	N 570	Sechskantschraube	Hex. screw	Vis hexagonale	0.020	M 10 x 16	DIN 933
		2	6	N 1649	Schwingmetall	Vibration isolator	A amortisseur	0.125	Ø 50 x 20	
			7	N 198	Sechskantschraube	Hex. screw	Vis hexagonale	0.018	M 8 x 20	DIN 933
			8	N 58	Scheibe	Washer	Rondelle	0.005	Ø 8,4	DIN 125
			9	N 108	Federring	Lock washer	Rondelle élastique	0.005	A 8	DIN 127
			10	N 57	Sechskantmutter	Hex. nut	Ecrou hexagonal	0.005	M 8	DIN 934
			11	14446-620	Abdeckplatte	Cover plate	Plaque de recouvrement	0.300	U3E, U3W, /-H	
			12	14721-760	Befestigungswinkel	Mounting angle	Equerre de fixation	0.050	U2B, /-H	
			13	N 542	Sechskantschraube	Hex. screw	Vis hexagonale	0.015	M 6 x 16	DIN 933
			14	N 2757	Plastikkappe	Plastic cap	Bouchon plastique	0.007		
		2	15	N 370	Sechskantmutter, selbsts.	Hex. nut, self-locking	Ecrou hex., auto-freinant	0.009	NM 8	DIN 980
			16	13489-864	Gummischeibe	Rubber washer	Rondelle en caoutchouc		Ø 8 x 20	
			17	N 88	Sechskantschraube	Hex. screw	Vis hexagonale	0.016	M 8 x 25	DIN 933
			18	14401-620	Riemenschutz	Belt guard	Protection de courroie	2.200		
			19	N 680	Sechskantschraube	Hex. screw	Vis hexagonale	0.005	M 6 x 35	DIN 933
			20	N 89	Sechskantschraube	Hex. screw	Vis hexagonale	0.020	M 8 x 30	DIN 933
			21	N 3526	Plastikkappe	Plastic cap	Bouchon plastique		20 x 20 x 2	
			22	14349-615	Motorwippe	Pedestal	Moto-interrupteur à bascule	1.460	U2B, U3E, U3W, /-H	
			23	14450-655	Anschlagwinkel	Stop angle	Equerre de butée	0.050	U2B, /-H	
		1	24	N 1899	Anschlagpuffer	Vibration isolator	Amortisseur	0.015	U2B, /-H	
			25	N 100	Federring	Lock washer	Rondelle élastique	0.001	A 6	DIN 127
			26	N 287	Sechskantmutter	Hex. nut	Ecrou hexagonal	0.005	M 6	DIN 934
			27	64912-620	Abdeckplatte	Cover plate	Plaque de recouvrement			
			28	N 53	Sechskantschraube	Hex. screw	Vis hexagonale	0.005	M 6 x 16	DIN 933
			29	N 102	Scheibe	Washer	Rondelle	0.010	Ø 6,4	DIN 125
			30	12731-635	Füllventilbefestigung	Filling valve mounting	Fixation robinet de rempliss.	0.025		

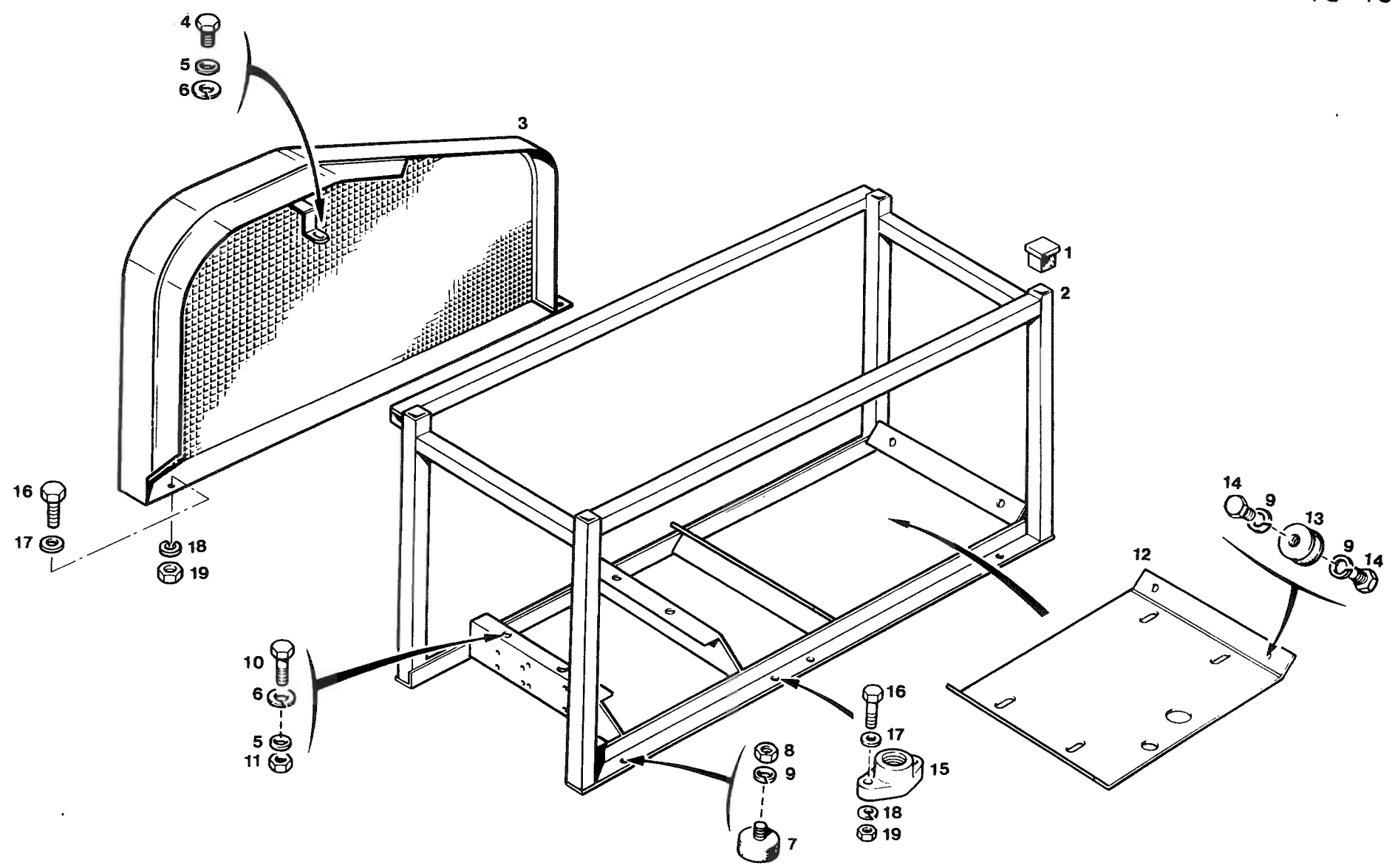



Ersatzteilsatz
Spare parts sets
Kits de pièces det.

Bildtafel TU-13 Rahmen - Dieselmotor
Figure TU-13 Frame - Diesel engine
Planche TU-13 Cadre - moteur Diesel

Klasse Class Classe			Pos	Bestell-Nr Part No. No. de cde.	Benennung	Designation	Dénomination	Gewicht Weight Poids (kg)	Abmessungen Dimensions Dimensions		
0	2	5									
			1	N 2757	Plastikkappe	Plastic cap	Bouchon plastique	0.007	30 x 30 x 2		
			2	55279-760	Rahmen	Frame	Cadre				
			3	55281-620	Riemenschutz	Belt guard	Protection de courroie				
			4	N 198	Sechskantschraube	Hex. screw	Vis hexagonale	0.018	M 8 x 20	DIN 933	
			5	N 58	Scheibe	Washer	Rondelle	0.005	Ø 8,4	DIN 125	
			6	N 108	Federring	Lock washer	Rondelle élastique	0.005	A 8	DIN 127	
		4	7	N 1547	Schwingmetall	Vibration isolator	Amortisseur	0.085	Ø 50 x 15		
			8	N 177	Sechskantmutter	Hex. nut	Ecrou hexagonal	0.015	M 10	DIN 934	
			9	N 176	Federring	Lock washer	Rondelle élastique	0.005	A 10	DIN 127	
			10	N 89	Sechskantschraube	Hex. screw	Vis hexagonale	0.020	M 8 x 30	DIN 933	
			11	N 57	Sechskantmutter	Hex. nut	Ecrou hexagonal	0.005	M 8	DIN 934	
			12	55280-760	Motorwippe	Pedestal	Moto-interrupteur à bascule				
		2	13	N 3290	Schwingmetall	Vibration isolator	Amortisseur	0.140	Ø 50 x 45, 45 Sh.		
			14	N 570	Sechskantschraube	Hex. screw	Vis hexagonale	0.020	M 10 x 16	DIN 933	
			15	12731-635	Füllventilbefestigung	Filling valve mounting	Fixation robinet de rempliss.	0.025			
			16	N 680	Sechskantschraube	Hex. screw	Vis hexagonale	0.005	M 6 x 35	DIN 933	
			17	N 102	Scheibe	Washer	Rondelle	0.010	Ø 6,4	DIN 125	
			18	N 100	Federring	Lock washer	Rondelle élastique	0.001	A 6	DIN 127	
			19	N 287	Sechskantmutter	Hex. nut	Ecrou hexagonal	0.005	M 6	DIN 934	

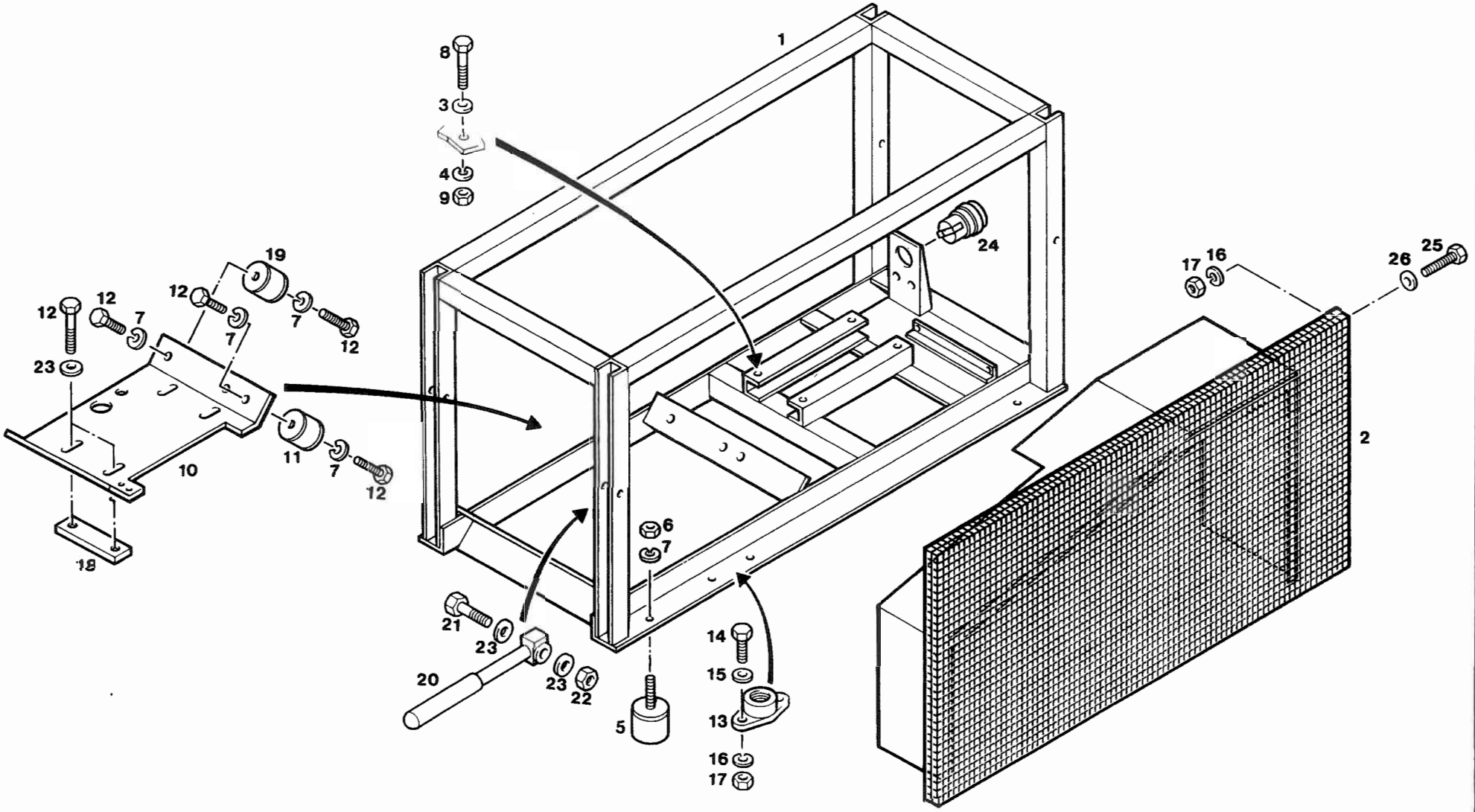



Ersatzteilsätze
Spare parts sets
Kits de pièces dét.

Bildtafel TU-14 Rahmen - Dieselmotor mit Anlasser
Figure TU-14 Frame - Diesel engine with electric starter
Planche TU-14 Cadre - moteur Diesel avec démarrage électrique

Klasse Class Classe			Pos.	Bestell-Nr Part No. No. de cde.	Benennung	Designation	Dénomination	Gewicht Weight Poids (kg)	Abmessungen Dimensions Dimensions	
0	2	5								
			1	66336-760	Rahmen	Frame	Cadre			
			2	66576-620	Riemenschutz	Belt guard	Protection de courroie			
			3	N 58	Scheibe	Washer	Rondelle	0.005	Ø 8,4	DIN 125
			4	N 108	Federring	Lock washer	Rondelle élastique	0.005	A 8	DIN 127
		4	5	N 1547	Schwingmetall	Vibration isolator	A mortisseur	0.085	Ø 50 x 15	
			6	N 177	Sechskantmutter	Hex. nut	Ecrou hexagonal	0.015	M 10	DIN 934
			7	N 176	Federring	Lock washer	Rondelle élastique	0.005	A 10	DIN 127
			8	N 89	Sechskantschraube	Hex. screw	Vis hexagonale	0.020	M 8 x 30	DIN 933
			9	N 57	Sechskantmutter	Hex. nut	Ecrou hexagonal	0.008	M 8	DIN 934
			10	64857-760	Motorwippe	Pedestal	Moto-interrupteur à bascule			
		1	11	N 3290	Schwingmetall	Vibration isolator	A mortisseur	0.140	Ø 50 x 45, 45 Sh.	
			12	N 570	Sechskantschraube	Hex. screw	Vis hexagonale	0.020	M 10 x 16	DIN 933
			13	12731-635	Füllventilbefestigung	Filling valve mounting	Fixation robinet de rempliss.	0.025		
			14	N 680	Sechskantschraube	Hex. screw	Vis hexagonale	0.005	M 6 x 35	DIN 933
			15	N 102	Scheibe	Washer	Rondelle	0.010	Ø 6,4	DIN 125
			16	N 100	Federring	Lock washer	Rondelle élastique	0.005	A 6	DIN 127
			17	N 287	Sechskantmutter	Hex. nut	Ecrou hexagonal	0.008	M 6	DIN 934
			18	64884-670	Befestigungsleiste	Fixation	Bande de fixation			
		1	19	N 3291	Schwingmetall	Vibration isolator	A mortisseur	0.190	Ø 50 x 45, 55 Sh.	
			20	14005-760	Traggriff	Handle	Poignée			
			21	N 350	Sechskantschraube	Hex. screw	Vis hexagonale	0.045	M 10 x 55	DIN 931
			22	N 644	Sechskantmutter	Hex. nut	Ecrou hexagonal	0.015	NM 10	DIN 980
			23	N 16	Scheibe	Washer	Rondelle	0.004	B 10,5	DIN 125
		1	24	N 1734	Betriebstundenzähler	Hour-meter	Compteur horaire			
			25	N 1553	Sechskantschraube	Hex. screw	Vis hexagonale	0.005	M 6 x 12	DIN 933
			26	N 3313	Scheibe	Washer	Rondelle	0.004	A 6,4	DIN 9021

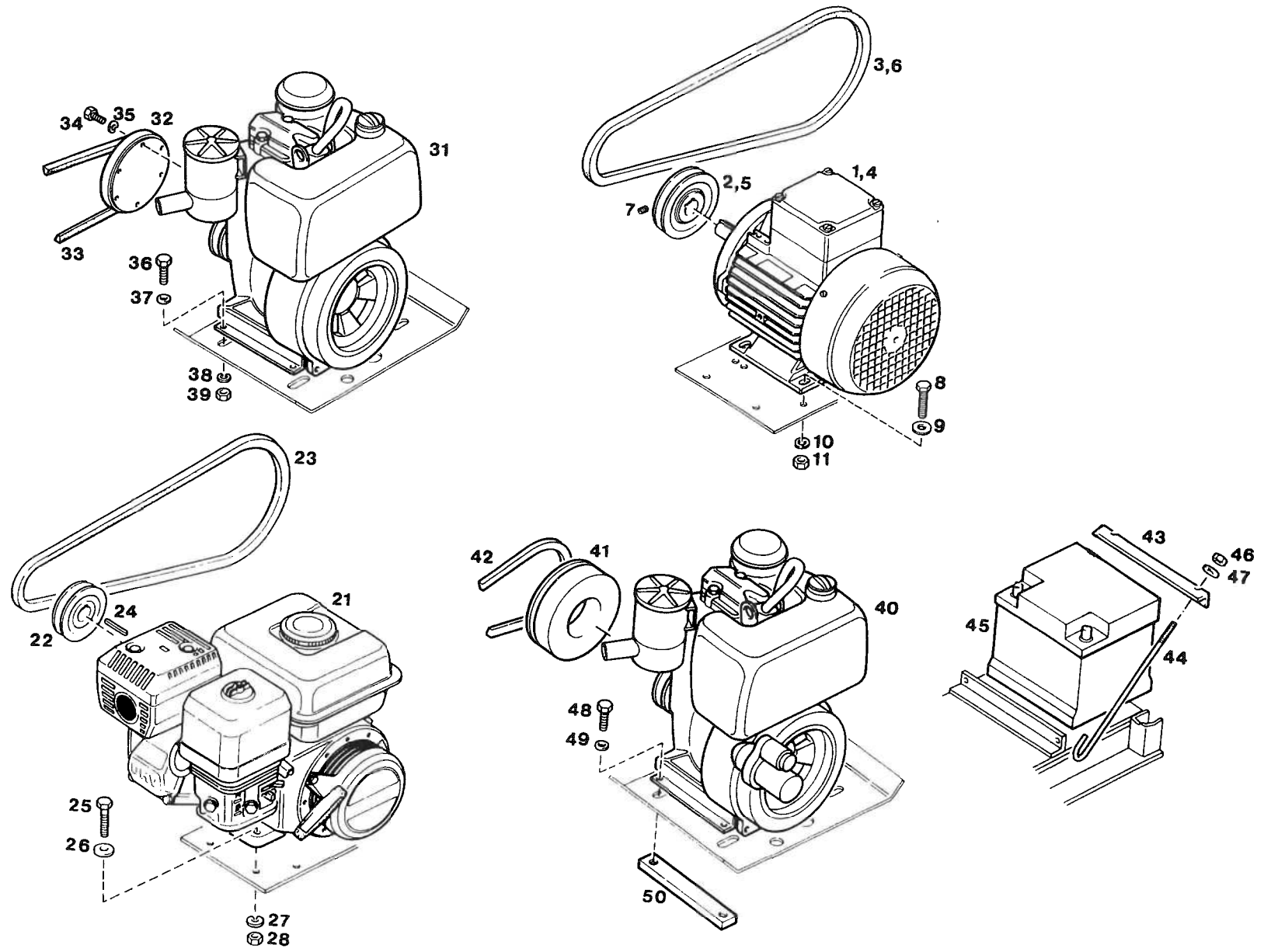



Ersatzteilsatz
Spare parts sets
Kits de pièces dét.

Bildtafel TU-15 Antriebsmotoren mit Zubehör
Figure TU-15 Drive motors with accessories
Planche TU-15 Moteurs d'entraînement avec accessoires

Klasse Class Classe			Pos.	Bestell-Nr Part No. No. de cde.	Benennung	Designation	Dénomination	Gewicht Weight Poids (kg)	Abmessungen Dimensions Dimensions
0	2	5							
1	2		1	N 3388	Für Anlage U3E/-H Drehstrommotor	For unit U3E/-H Three-phase motor	Pour le groupe U3E/-H Moteur triphasé	13.50	50 Hz, 2,2 kW
			2	14386-130	Keilriemenscheibe	V-belt pulley	Poulie à gorge	2.120	Ø 170, 50 Hz
			3	N 2586	Keilriemen	V-belt	Courroie trapézoïdale	0.129	9,5 x 1725 La
1	2		4	N 15750	Für Anlage U3W/-H Wechselstrommotor	For unit U3W/-H Single-phase motor	Pour le groupe U3W/-H Moteur à courant alternatif	19.00	50 Hz, 2,2 kW
			5	14386-130	Keilriemenscheibe	V-belt pulley	Poulie à gorge	2.120	Ø 170, 50 Hz
			6	N 3544	Keilriemen	V-belt	Courroie trapézoïdale	0.110	9,5 x 1662 Lw
			7	N 106	Gewindestift	Stud	Vis sans tête	0.010	M 8 x 12
			8	N 89	Sechskantschraube	Hex. screw	Vis hexagonale	0.020	M 8 x 30 DIN 933
			9	N 58	Scheibe	Washer	Rondelle	0.005	Ø 8,4 DIN 125
			10	N 108	Federring	Lock washer	Rondelle élastique	0.005	A 8 DIN 127
			11	N 57	Sechskantmutter	Hex. nut	Ecrou hexagonal	0.008	M 8 DIN 934
			21	N 16176	Für Anlage U2B/-H Benzinmotor	For unit U2B/-H Gasoline engine	Pour le groupe U2B/-H Moteur à essence	2.700	Honda, 3.7 kW
			22	14403-130	Keilriemenscheibe	V-belt pulley	Poulie à gorge	0.105	Ø 134
			23	N 3543	Keilriemen	V-belt	Courroie trapézoïdale	0.006	9,5 x 1675 La
24	N 2885	Paßfeder	Key	Clavette	0.006	3/16"x3/16"x1" lg.			
25	N 64	Sechskantschraube	Hex. screw	Vis hexagonale	0.021	M 8 x 35 DIN 933			
26	N 58	Scheibe	Washer	Rondelle	0.005	Ø 8,4 DIN 125			
27	N 108	Federring	Lock washer	Rondelle élastique	0.005	A 8 DIN 127			
28	N 57	Sechskantmutter	Hex. nut	Ecrou hexagonale	0.008	M 8 DIN 934			
1	2		31	N 3807	Für Anlage U4D/-H Dieselmotor	For unit U4D/-H Diesel engine	Pour le groupe U4D/-H Moteur Diesel		4,5 kW
			32	56945-130	Keilriemenscheibe	V-belt pulley	Poulie à gorge		Ø 133
			33	N 2586	Keilriemen	V-belt	Courroie trapézoïdale	0.129	9,5 x 1725 La
			34	N 796	Innensechskantschraube	Allen screw	Vis à six pans creux	0.015	M 6 x 25 DIN 912
			35	N 100	Federring	Lock washer	Rondelle élastique	0.001	A 6 DIN 127
			36	N 3155	Sechskantschraube	Hex. screw	Vis hexagonale	0.015	M 10 x 25 DIN 933
			37	N 16	Scheibe	Washer	Rondelle	0.006	Ø 10,5 DIN 125
			38	N 176	Federring	Lock washer	Rondelle élastique	0.005	A 10 DIN 127
			39	N 177	Sechskantmutter	Hex. nut	Ecrou hexagonal	0.015	M 10 DIN 934
			40	N 17635	Für Anlage U4DA/-H Dieselmotor mit Anlasser	For unit U4DA/-H Diesel engine with el. starter	Pour le groupe U4DA/-H Moteur Diesel, démarrage él.		4 kW
			41	66337-130	Keilriemenscheibe	V-belt pulley	Poulie à gorge		
42	N 2729	Keilriemen	V-belt	Courroie trapézoïdale		9,5 x 1737 La			
43	65017-760	Befestigungswinkel	Bracket	Equerre de fixation					
44	4498-630	Befestigungshaken	Fastener	Crochet de fixation					
45	N 17198	Batterie	Battery	Batterie		36 Ah, 12 V			

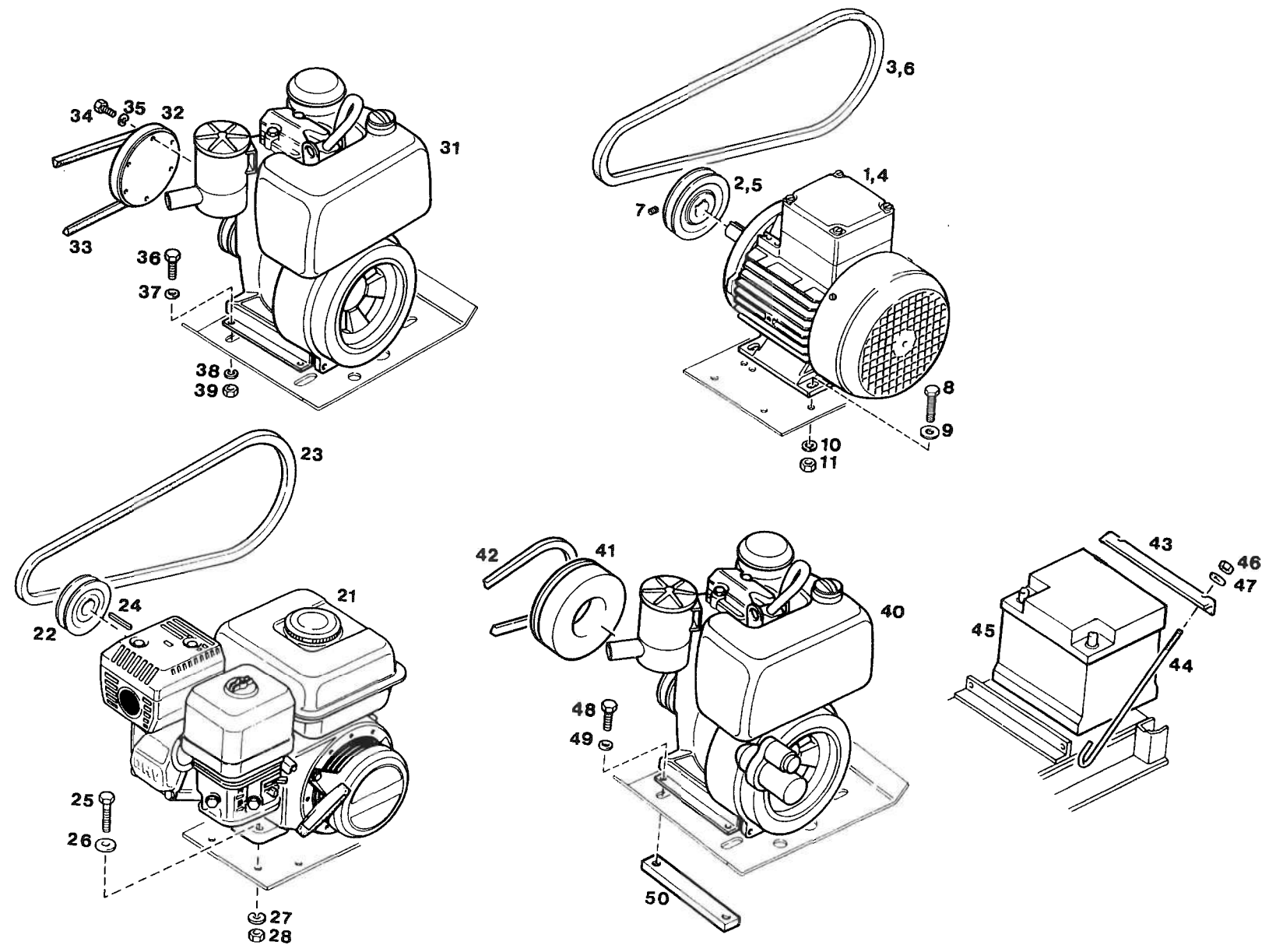



Ersatzteilsätze
Spare parts sets
Kits de pièces dét.

Bildtafel TU-15 Antriebsmotoren mit Zubehör
Figure TU-15 Drive motors with accessories
Planche TU-15 Moteurs d'entraînement avec accessoires

Klasse Class Classe			Pos.	Bestell-Nr. Part No. No. de cde.	Benennung	Designation	Dénomination	Gewicht Weight Poids (kg)	Abmessungen Dimensions Dimensions
0	2	5							
			46	N 1042	Sechskantmutter	Hex. nut	Ecrou hexagonal	0.005	NM 6, DIN 980
			47	N 102	Scheibe	Washer	Rondelle	0.010	B 6,4, DIN 125
			48	N 3155	Sechskantschraube	Hex. screw	Vis hexagonale	0.015	M 10 x 25 DIN 933
			49	N 16	Scheibe	Washer	Rondelle	0.006	Ø 10,5 DIN 125
			50	64884-670	Befestigungsleiste	Attachment bar	Barre de fixation		

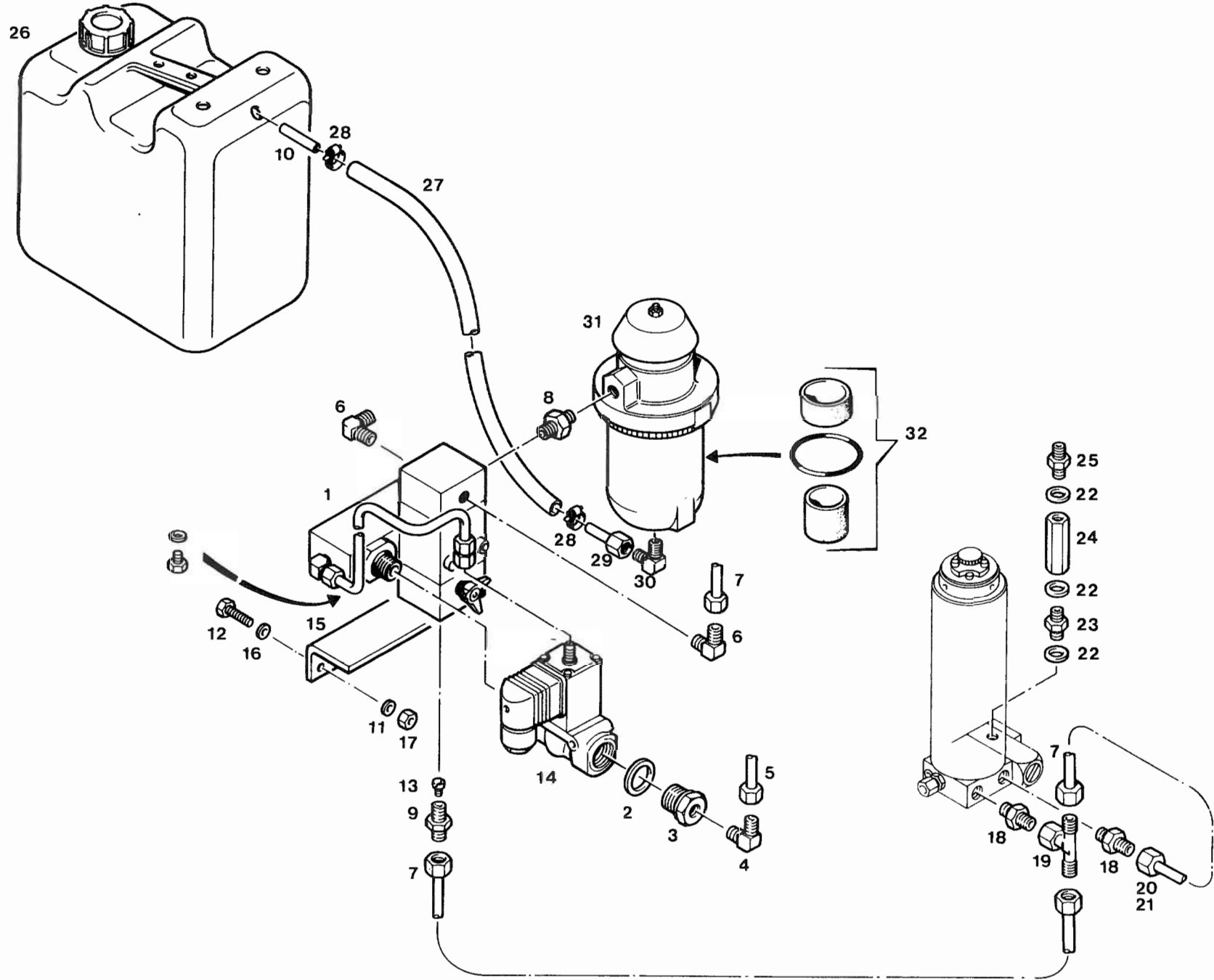

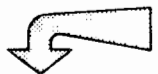

Ersatzteilsätze
Spare parts sets
Kits de pièces dét.

Bildtafel KA-2 Kondensatablaßautomatik 068222-342
Figure KA-2 Automatic condensate drain 068222-342
Planche KA-2 Purge automatique des condensats 068222-342

Klasse Class Classe			Pos.	Bestell-Nr. Part No. No. de cde.	Benennung	Designation	Dénomination	Gewicht Weight Poids (kg)	Abmessungen Dimensions Dimensions
0	2	5							
1	1	2	1	063760-342	Kondensatablaßventil-Baugruppe	Condensate drain valve assembly	Soupape de purge des condensats, groupe d'assemblage		
			2	N 293	Dichtung	Gasket	Joint		A 21 x 28 DIN 7603
			3	N 9155	Reduzierung	Reducer	Réducteur	0.060	ri 1/2" x 1/4"
			4	N 3458	Winkelrohrverschraubung	Male elbow	Raccord coudé mâle	0.073	WE 12-LLR
			5	N 15098	Verbindungsleitung*	Connection*	Conduite de connexion*		Ø 12x1 DIN 2462
			6	N 1057	Winkelrohrverschraubung	Male elbow	Raccord coudé mâle	0.035	WE 6-PLR
			7	N 3616	Verbindungsleitung*	Connection*	Conduite de connexion*	0.035	Ø 6x1 DIN 2462
			8	N 3734	Doppelnippel	Nipple	Pièce intermédiaire	0.050	R 1/2" x R 3/8"
			9	062984-342	Rohrverschraubung mit Düse	Connector	Pièce int. avec buse		
			11	N 100	Federring	Spring washer	Rondelle élastique	0.004	A 6 DIN 127
			12	N 53	Sechskantschraube	Hex. screw	Vis hexagonale	0.005	M 6 x 12 DIN 933
			13	66550-342	Düse	Nozzle	Buse		0,8 mm
			14	N 16270	Zwei-Wege-Magnetventil**	2-way solenoid valve**	Electrovanne 2 voies**		220 V, 40-60 Hz
				N 16382	Zwei-Wege-Magnetventil**	2-way solenoid valve**	Electrovanne 2 voies**		115 V, 50-60 Hz
				N 16384	Zwei-Wege-Magnetventil**	2-way solenoid valve**	Electrovanne 2 voies**		240 V, 50-60 Hz
				N 16381	Zwei-Wege-Magnetventil**	2-way solenoid valve**	Electrovanne 2 voies**		12 VDC
				N 16387	Zwei-Wege-Magnetventil**	2-way solenoid valve**	Electrovanne 2 voies**		24 VDC
			15	68220-655	Montagewinkel	Bracket	Fixation		
			16	N 102	Scheibe	Washer	Rondelle	0.010	6,4 DIN 125
			17	N 287	Sechskantmutter	Hex. screw	Vis hexagonale	0.005	M 6 DIN 934
			18	63666-635	Anschlußstück für Triplex-Filter	Adapter for Triplex filter	Pièce de raccordement pour filtre Triplex		
			19	N 15138	Einstellbare T-Verschraubung	Male run T	Raccord en T orientable	0.085	evT-6 PSR
			20	N 3610	Überwurfmutter	Cap screw	Ecrou	0.015	m6-s
			21	N 3663	Schneidring	Compression ring	Bague coupante	0.002	dpr6-s
			22	N4602	Usit Ring	Usit-ring	Joint Usit		UJ 14-18,7-1,5
			23	9068-635	Doppelnippel	Adapter	Pièce intermédiaire		
			24	1463-330	Rückschlagventil	Non-return valve	Clapet anti-retour		NW 5, 450 bar
			25	65363-635	UNIMAM-Verschraubung	UNIMAM connector	Raccord UNIMAM		
			26	65267-342	Kondensatbehälter***	Condensate collector***	Réceptacle de condensats***		10 Ltr.
			27	N 3126	Schlauch***	Hose***	Tuyau***		Ø 8 x 2 x 450
			28	N 3133	Schlauchklemme***	Hose clamp***	Collier pour tuyaux***		Ø 8-12
			29	N 3618	Rohrstück	Tube	Tube	0.035	Ø 8x1x50 DIN 2462
30	N 3723	Winkelrohrverschraubung	Male elbow	Raccord coudé mâle	0.034	WE 8-LLR			
31	N 15051	Filter-Schalldämpfer	Filter silencer	Silencieux de filtre					
1	1	2	32	N 15052	Reparatursatz	Maintenance kit	Kit de réparation		

* Meterware; bei Bestellung Länge angeben
** Bei Bestellung Spannung und Frequenz angeben
*** Zusatzausstattung

* Piece goods; specify length on order
** Please specify voltage and frequency on order
*** Optional extra

* Marchandise au mètre; indiquer la longueur à la cde.
** Indiquer le voltage et la fréquence à la cde.
*** Equipement supplémentaire

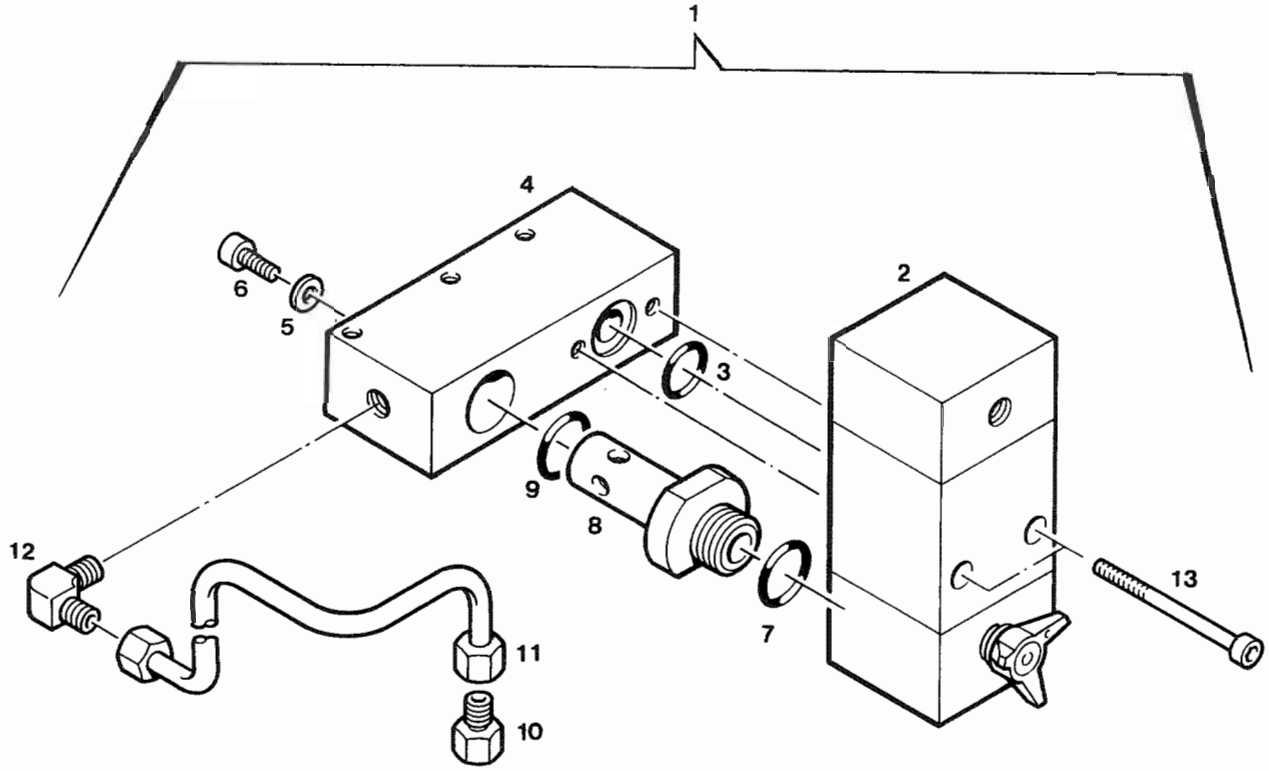



Ersatzteilsätze
Spare parts sets
Kits de pièces det.

Bildtafel KA-3 Kondensatablaßventil-Baugruppe 063760-342
Figure KA-3 Condensate drain valve assembly 063760-342
Planche KA-3 Soupape de purge des condensats, groupe d'assemblage 063760-342

Klasse Class Classe			Pos.	Bestell-Nr Part No. No. de cde.	Benennung	Designation	Dénomination	Gewicht Weight Poids (kg)	Abmessungen Dimensions Dimensions	
0	2	5								
			1	063760-342	Kondensatablaßventil-Baugruppe	Condensate drain valve assembly	Soupape de purge des condensats, groupe d'assemblage		..	
1	1	2	2	064008-342	Kondensatablaßventil kpl.	Drain valve assy.	Soupape de purge cpl.	0.005	Ø 11 x 2.5	
			3	N 638	O-Ring	O-ring	Joint torique			
1	1	2	4	64006-342	Sammelleiste	Manifold	Listeau collecteur			
			5	N 3625	Dichtung	Gasket	Joint	0.005	8x14 x 1.5 DIN 7603	
			6	N 829	Innensechskantschraube	Allen screw	Vis à six pans creux	0.020	M 8 x 16 DIN 912	
1	1	2	7	N 2320	O-Ring	O-ring	Joint torique	0.002	Ø 21.95 x 1.78	
			8	64004-342	Ventilverbindung	Valve connection	Raccord de soupape			
1	1	2	9	N 2507	O-Ring	O-ring	Joint torique	0.005	Ø 18.77 x 1.78	
			10	64010-342	Gerade Rohrverschraubung	Male connector	Raccord droit mâle			
			11	N 3616	Verbindungsleitung*	Connection*	Conduite de connexion*	0.035	Ø 6 x 1 DIN 2462	
			12	N 683	Winkelrohrverschraubung	Male elbow	Raccord coudé mâle	0.025	WE 6-LLR	
			13	N 724	Innensechskantschraube	Allen screw	Vis à six pans creux	0.010	M 6 x 40 DIN 912	
					* Meterware; bei Bestellung Länge angeben	* Piece goods; specify length on order	* Marchandise au mètre; indiquer la longueur à la cde.			

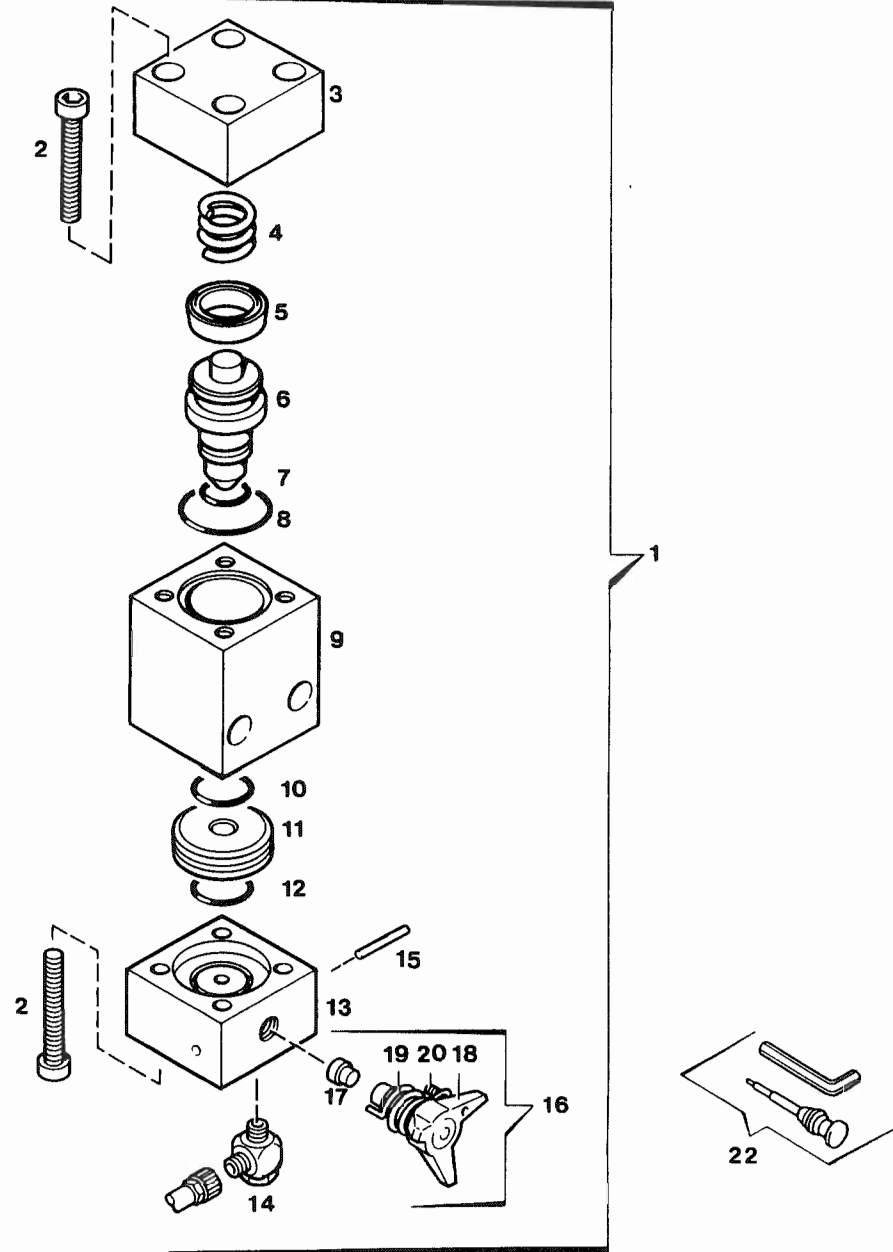



Ersatzteilsätze
Spare parts sets
Kits de pièces dét.

Bildtafel KA-4 Kondensatablaßventil 064008-342
Figure KA-4 Condensate drain valve 064008-342
Planche KA-4 Soupape de purge des condensats 064008-342

Klasse Class Classe			Pos.	Bestell-Nr. Part No. No. de cde.	Benennung	Designation	Dénomination	Gewicht Weight Poids (kg)	Abmessungen Dimensions Dimensions
0	2	5							
			1	064008-342	Kondensatablaßventil kpl.	Condensate drain purge assy.	Soupape de purge des condensats cpl.	0.425	
			2	N 178	Innensechskantschraube	Allen screw	Vis à six pans creux	0.008	M 6 x 30 DIN 912
			3	64000-342	Kopfteil	Top flange	Partie supérieure	0.070	
			4	64011-640	Feder	Spring	Ressort	0.015	
	1	2	5	N 16269	Nutring	Sealing ring	Bague à gorge		25 x 17 x 5,5
	1	2	6	64003-342	Kolben	Piston	Piston	0.025	
1	1	2	7	N 638	O-Ring	O-ring	Joint torique	0.001	Ø 11 x 2,5
1	1	2	8	N 4881	O-Ring	O-ring	Joint torique	0.002	Ø 25 x 2
			9	64001-342	Mittelteil	Valve body	Corps de soupape	0.135	
1	1	2	10	N 2507	O-Ring	O-ring	Joint torique	0.001	Ø 18.77 x 1.78
	1	2	11	64005-342	Ventilsitz	Valve seat	Siège de soupape	0.010	
1	1	2	12	N 4496	O-Ring	O-ring	Joint torique		Ø 14 x 1.78
			13	64002-342	Fußteil	Base flange	Partie inférieure	0.095	
			14	N 16982	Schwenkverschraubung	Adjustable male branch T	Raccord en T orientable		
			15	N 16438	Zylinderstift	Stud	Goupille fileté		Ø 2m 6x18 DIN 6325
	1	2	16	065500-635	Knebelschraube kpl.	Drain tap assy.	Robinet de purge cpl.		
2	2	4	17	64498-635	Dichtung	Gasket	Joint		
			18	11392-635	Knebelschraube	Drain tap	Robinet		
			19	65310-640	Schenkelfeder	Spring	Ressort à branches		
			20	N 16947	Gewindestift	Stud	Vis sans tête	0.008	
			21	N 15088	Schlauch	Hose	Tuyau		
			22	067458-645	Werkzeugsatz f. Knebelschraube	Tool set for petcock handle	Jeu d'outils pour robinet		

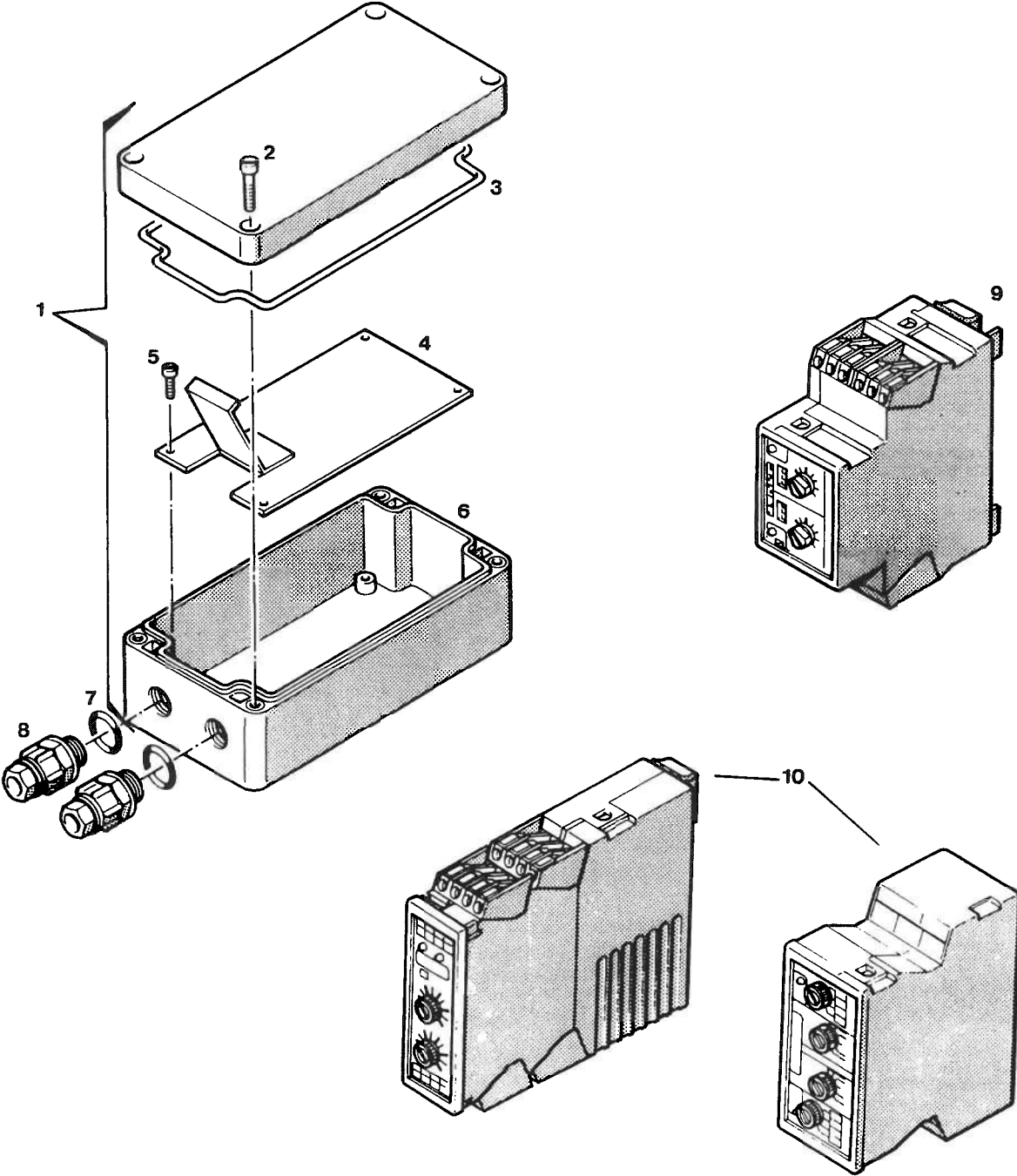



Ersatzteilsätze
Spare parts sets
Kits de pièces dét.

Bildtafel KA-5 Elektronische Laufschtaltwerke
Figure KA-5 Electrical timers
Planche KA-5 Minuterics électriques

Klasse Class Classe			Pos.	Bestell-Nr Part No. No. de cde.	Benennung	Designation	Dénomination	Gewicht Weight Poids (kg)	Abmessungen Dimensions Dimensions
0	2	5							
			1	068518-992	Gehäuse kpl.	Housing assy.	Boîtier cpl.		
			2		Zylinderschraube	Cylindric head screw	Vis cylindrique		
			3		Dichtgummi	Gasket	Joint		
			4	68517-655	Montageplatte	Mounting plate	Plaque de montage		
			5		Zylinderschraube	Cylindric screw	Vis cylindrique		
			6	N 18280	Gehäuse	Housing	Boîtier		
			7		Dichtgummi	Gasket	Joint		
			8	N 3101	Kunststoffverschraubung	Screw type gland	Raccord plastique		PG 11
			9	N 18484	Pause und Impuls einstellbar: 0-10 Std. Laufschtaltwerk	Pulse and Pause adjustable: 0-10 hours Electrical timer	Marche et arrêt ajustables: 0-10 heures Minuterie électrique		24-240 V, 45-65 Hz
			10	N 16202 N 18410 N 18411 N 17942 N 18412 N 18367	Pause und Impuls einstellbar: wahlweise 30 min./30 s Laufschtaltwerk, elektronisch Laufschtaltwerk, elektronisch Laufschtaltwerk, elektronisch Laufschtaltwerk, elektronisch Laufschtaltwerk, elektronisch Laufschtaltwerk, elektronisch	Pulse and Pause adjustable: optional 30 min./30 s Electrical timer Electrical timer Electrical timer Electrical timer Electrical timer Electrical timer	Marche et arrêt ajustables: au choix 30 min./30 s Minuterie électrique Minuterie électrique Minuterie électrique Minuterie électrique Minuterie électrique Minuterie électrique	220 V, 50-60 Hz 115 V, 50-60 Hz 240 V, 50-60 Hz 12 V= 24 V= 24 V, 50-60 Hz	