



Teileliste
Spare parts list
Catalogue des pièces

TU-1/2

UTILUS

UTILUS-H

1/2 Auflage · Mai 1988

1/2 Edition · May 1988

1/2 Edition · Mai 1988

Hochdruckkompressoren
High pressure compressors
Compresseurs à haute pression

TEILELISTE

TU-1/2

PARTS LIST

TU-1/2

CATALOGUE DES PIECES TU-1/2

ist gültig ab:

Mai 1988

is valid as of:

May 1988

est valable à partir du:

Mai 1988

für:

for

pour

Kompressor

U1-H, U3E-H, U4D-H

Compressor

U1-H, U3E-H, U4D-H

Type de Compresseur

U1-H, U3E-H, U4D-H

Fabrik-Nr.:

XXX-XXXX/9/7

Serial No.:

XXX-XXXX/9/7

No. de fabrication:

XXX-XXXX/9/7

Kompressor

U2B-H, U3W-H, U3E-H und
mit Sturzrahmen

Compressor

U2B-H, U3W-H, U3E-H and
with protection frame

Type de Compresseur

U2B-H, U3W-H, U3E-H et
avec cadre de protection

Fabrik-Nr.:

XXX-XXXX/9/8

Serial No.:

XXX-XXXX/9/8

No. de fabrication:

XXX-XXXX/9/8

Kompressor

U1, U3E, U4D

Compressor

U1, U3E, U4D

Type de Compresseur

U1, U3E, U4D

Fabrik-Nr.:

XXX-XXXX/9/9

Serial No.:

XXX-XXXX/9/9

No. de fabrication:

XXX-XXXX/9/9

Kompressor

U2B, U3W, U3E und
mit Sturzrahmen

Compressor

U2B, U3W, U3E and
with protection frame

Type de Compresseur

U2B, U3W, U3E et
avec cadre de protection

Fabrik-Nr.:

XXX-XXXX/9/10

Serial No.:

XXX-XXXX/9/10

No. de fabrication:

XXX-XXXX/9/10

Die hier enthaltenen Beschreibungen und Abbildungen sind unverbindlich; BAUER-Kompressoren behält sich daher im Interesse der Weiterentwicklung das Recht vor, jederzeit an Hauptorganen und einzelnen Bestand- oder Zubehörtteilen die Änderungen vorzunehmen, die sie unter Beibehaltung der wesentlichen Merkmale der hier beschriebenen Typen, zur Steigerung der Leistungsfähigkeit oder aus irgendeinem sicherheits- oder handelstechnischen Grund für zweckmäßig hält.

BAUER-Kompressoren ist ferner nicht verpflichtet, vorliegende Dokumentation diesbezüglich gleichzeitig zu berichtigen.

All information and illustrations are without obligation - we reserve the right to make changes to all individual items and accessories according to state of the art requirements in improving performance or as necessitated by safety or commercial restrictions.

BAUER Kompressoren is, in addition, not obliged to up-date these operating instructions accordingly simultaneously with change.

Les descriptions et illustrations contenues dans ce manuel sont sans engagement de notre part; dans l'intérêt du développement ultérieur de nos appareils, nous nous réservons donc le droit de procéder, à tout moment, sur les organes principaux, et sur chaque élément ou accessoire de nos appareils, aux modifications qui, tout en respectant les caractéristiques essentielles des types ici décrits, nous sembleront nécessaires pour augmenter le rendement de nos appareils ou pour toute autre raison commerciale ou de sécurité.

Nous ne sommes pas non plus obligés de procéder, en même temps, à la revision correspondante du présent documentation.

Wichtige Hinweise für Teilebestellung:

Bestell-Nr., die mit der Ziffer 0 beginnen, bezeichnen Teile, die komplett geliefert werden.

Teile ohne Bestell-Nr. sind nur zur Information für die Montage aufgeführt. Diese Teile sind nicht als Ersatzteile erhältlich.

Bei Ersatzteilbestellungen erwarten Sie unsere richtige Lieferung; deshalb benötigen wir von Ihnen folgende Angaben:

1. Kompressorartyp: UTILUS
2. Fabrik-Nr.
3. Stückzahlen
4. Benennung und Bestell-Nr. des gewünschten Teils.

Bestell-Beispiel:

Für Utilus, Kompressor Nr. 525-0867
3 Dichtungen Nr. N 4466

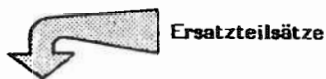

Ersatzteilsätze

Klassifizierung:

- 0 = Dichtungssatz; Bestell-Nr. N 5899
- 2 = Wartungssatz, 2 Jahre; Bestell-Nr. N 5900
- 5 = Wartungssatz, 5 Jahre; Bestell-Nr. N 5901

In den Spalten ist jeweils die im entsprechenden Satz enthaltene Teile-Stückzahl angegeben

ACHTUNG:

Nur Schrauben und Stiftschrauben der Qualität 8.8 verwenden!

Important notes for spare parts orders:

Part Nos. beginning with digit 0 indicate parts available as complete assemblies.

Parts without Part No. are indicated for assembly reference only. These parts are not available as single parts.

When placing an order for spare parts, please give the following items so as to ensure our correct delivery:

1. Compressor model: UTILUS
2. Serial No.
3. Quantity req'd
4. Name and Part No.

Example for order:

For Utilus, serial-no. 525-0867
3 gaskets N 4466



Spare Parts Sets

Classification:

- 0 = Set of gaskets; Part No. N 5899
- 2 = Maintenance kit, 2 years; Part no. N 5900
- 5 = Maintenance kit, 5 years; Part no. N 5901

The columns contain the number of parts that are included in the respective parts set

ATTENTION:

Use only screws and studs in quality 8.8. This quality is equivalent to SAE J 429 d grade 5.

Avis important pour la commande de pièces

Les nos. de commande commençant avec le chiffre 0 indiquent les pièces livrables en ensemble.

Les pièces sans no. de commande sont indiquées uniquement pour information de montage. Elles ne sont pas procurables comme pièces de rechange.

Pour que notre livraison de pièces de rechange corresponde à la commande que vous nous passez, veuillez bien nous fournir les données suivantes:

1. Type du compresseur: UTILUS
2. No. de fabrication
3. Quantité désirée
4. Dénomination et no. de commande de la pièce désirée.

Exemple de commande:

Pour Utilus, compresseur no. 525-0867
3 joints N 4466



Kits de pièces détachées

Classification:

- 0 = Kit de joints d'étanchéité; No. de cde. N 5899
- 2 = Kit d'entretien pour 2 ans; No. de cde. N 5900
- 5 = Kit d'entretien pour 5 ans; No. de cde. N 5901

La quantité des pièces indiquée dans les colonnes est incluse dans le kit de pièces correspondant.

ATTENTION:

N'utiliser que des vis et goujons de qualité 8.8

TEILELISTE TU-1/2

SPARE PARTS LIST TU-1/2

CATALOGUE DES PIECES TU-1/2

INHALTSVERZEICHNIS

INDEX

TABLE DES MATIERES

Kurbelgehäuse mit Zubehör, Triebwerk, Kolben, Zylinder	Crankcase with accessories, driving gear, pistons and cylinders	Carter avec équipements, embiellage pistons et cylindres	TU-1
Ventilkopf 1. Stufe	Valve head 1st stage	Culasse de 1er étage	TU-2
Ventilkopf 2. Stufe	Valve head 2nd stage	Culasse de 2e étage	TU-3
Ventilkopf 3. Stufe	Valve head 3rd stage	Culasse de 3e étage	TU-4
Kühler und Ventilator	Cooler and fan	Refroidisseur et ventilateur	TU-5
Öldruckschmierung	Lubrication system	Lubrification	TU-6
Ansaugfilter mit Ansaugschlauch	Intake filter with intake hose	Filtre d'aspiration avec tuyau d'aspiration	TU-7
Zwischenfilter und Sicherheitsventile	Interfilter and safety valves	Filtre intermédiaire, soupapes de sûreté	TU-8
Filtersystem P21	Filter system P21	Système de filtrage P21	TU-9
Umschaltvorrichtung PN 200 / PN 300	Change over device 3200 / 4700 psi	Dispositif selecteur PN 200 / PN 300	TU-10
Grundrahmen	Base frame	Cadre de base	TU-11
Sturzrahmen	Protection frame	Cadre de protection	TU-12
Grundrahmen Dieselmotor	Base frame - Diesel engine	Cadre de base - moteur Diesel	TU-13
Antriebsmotoren	Driving motors	Moteurs d'entraînement	TU-14
Kondensat-Ablassautomatik	Automatic drain device	Purge automatique	KA 1c

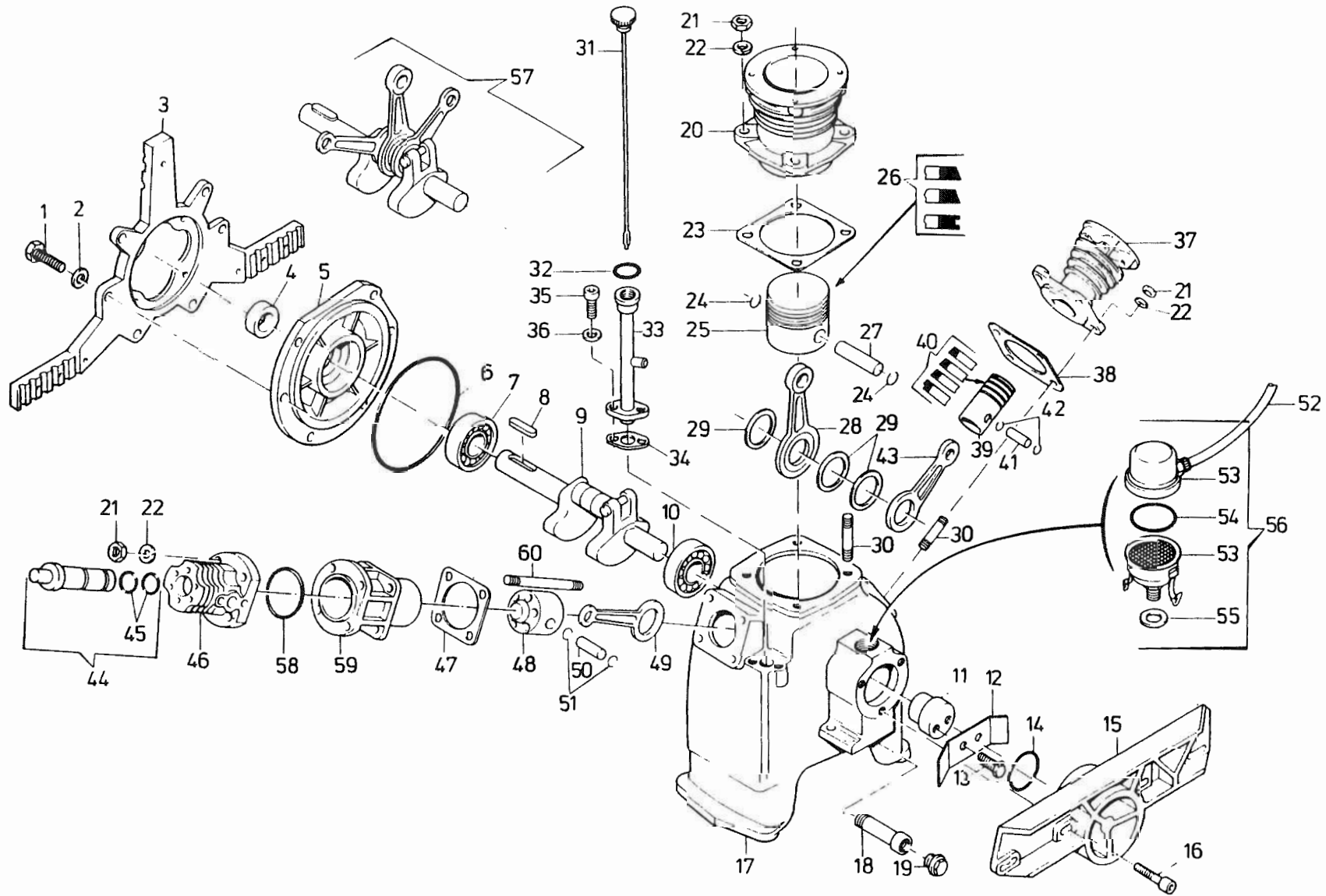



Ersatzteilsätze
Spare parts sets
Kits de pièces dét.

Bildtafel TU-1 Kurbelgehäuse mit Zubehör, Triebwerk, Kolben und Zylinder
Figure TU-1 Crankcase with accessories, driving gear, pistons and cylinders
Planche TU-1 Carter avec équipements, embiellage, pistons et cylindres

Klasse Class Classe			Pos.	Bestell-Nr. Part No. No. de cde.	Benennung	Designation	Dénomination	Gewicht Weight Poids (kg)	Abmessungen Dimensions Dimensions	
0	2	5								
			1	N 89	Sechskantschraube	Hex. screw	Vis six pans	0.020	M 8x30	DIN 933
			2	N 58	Scheibe	Washer	Rondelle	0.005	Ø 8.4	
			3	14998-860	Kühlrohrhalterung	Bracket for cooler	Fixation tube de refroidissement	0.695		
1			4	N 220	Wellendichtring	Shaft seal	Bague d'étanchéité	0.017	Ø 25x40x7	
			5	14878-030	Lagerdeckel	Cover	Couvrcl de palier	0.560		
1			6	N 3705	O-Ring	O-ring	Joint torique	0.012	Ø 140 x3	
			7	N 3703	Zylinderrollenlager	Roller bearing	Roulement à rouleaux cylindriques	0.240	Ø 25x62x17	
			8	N 166	Paßfeder	Key	Clavette	0.022	8x7x40	DIN 6885
			9	062981-010	Kurbelwelle kpl.	Crankshaft assy	Vilebrequin cpl.	2.064		
			10	N 3702	Zylinderrollenlager	Roller bearing	Roulement à rouleaux	0.150	Ø 20x52x15	
			11	3196-650	Exzenter	Eccentric	Excentrique	0.125		
			12	14888-655	Sicherungsblech	Locking plate	Tôle de sécurité	0.003		
1			13	N 53	Sechskantschraube	Hex. screw	Vis six pans	0.005	M 6x16	DIN 933
			14	N 3726	O-Ring	O-ring	Joint torique	0.004	Ø 40,2 x 3	
			15	58159-860	Filterhalterung	Filter mounting	Fixation du filtre	0.970		
			16	N 109	Innensechskantschraube	Allen screw	Vis six pans creux	0.020	M 8x30	DIN 912
			17	14874-000	Kurbelgehäuse	Crankcase	Carter	6.130		
			18	N 2911	Verlängerungsröhrchen	Extension	Tube de rallonge	0.125	R 3/8"x120 lg	DIN 910
			19	N 3707	Verschlußschraube	Plug	Bouchon	0.030	R 3/8"	DIN 910
			20	14913-060	Zylinder	Cylinder	Cylindre	2.350	Ø 60	
			21	N 57	Sechskantmutter	Hex. nut	Ecrou hex.	0.008	M 8	DIN 934
1			22	N 58	Scheibe	Washer	Rondelle	0.005	Ø 8.4	DIN 125
			23	1867-090	Dichtung	Gasket	Joint	0.003		
			24		Sicherungsring	Snap ring	Anneau d'arrêt	0.001		
			25	2002-050	Kolben	Piston	Piston	0.150	Ø 60	
			26	N 2001	Kolbenringsatz	Piston ring set	Jeu de segments de piston	0.039	Ø 60	
			27		Kolbenbolzen	Piston pin	Axe de piston			
			28	1502-040	Pleuel 1. Stufe	Piston-rod 1st stage	Bielle 1er étage	0.175		
			29	4180-040	Distanzscheibe	Spacer	Entretoise	0.005		
			30	N 215	Stiftschraube	Stud	Goujon	0.025	M 8x25	DIN 835
1			31	14886-650	Ölpeilstab	Oil dip stick	Jauge d'huile	0.038		
			32	N 3521	O-Ring	O-ring	Joint torique	0.005	Ø 21,82x3,53	
			33	14887-635	Öleinfüllstutzen	Oil filling pipe	Tubulure de remplissage	0.040		
1			34	12560-090	Dichtung	Gasket	Joint	0.005	A 32x27x2	DIN 7603
			35	N 210	Innensechskantschraube	Allen screw	Vis six pans creux	0.020	M 6x20	
			36	N 3026	Federscheibe	Lock washer	Rondelle élastique	0.001	A 6	DIN 117
			37	10875-060	Zylinder	Cylinder	Cylindre	1.300	Ø 36	
			38	3110-090	Dichtung	Gasket	Joint	0.005	Ø 36	
			39	N 2634	Kolben 2. Stufe	Piston 2nd stage	Piston 2e étage	0.095	Ø 36	
			40	N 4158	Kolbenringsatz	Piston ring set	Jeu de segments de piston	0.006	Ø 36	
			41		Kolbenbolzen	Piston pin	Boulon de piston			
			42		Sicherungsring	Snap ring	Anneau d'arrêt			
			43	4960-040	Pleuel 2. Stufe	Piston-rod 2nd stage	Bielle 2e étage	0.180		
			44	014609-050	Kolbenbüchse kpl. mit Freiflugkolben	Piston and sleeve assy	Douille et piston cpl.	0.270		

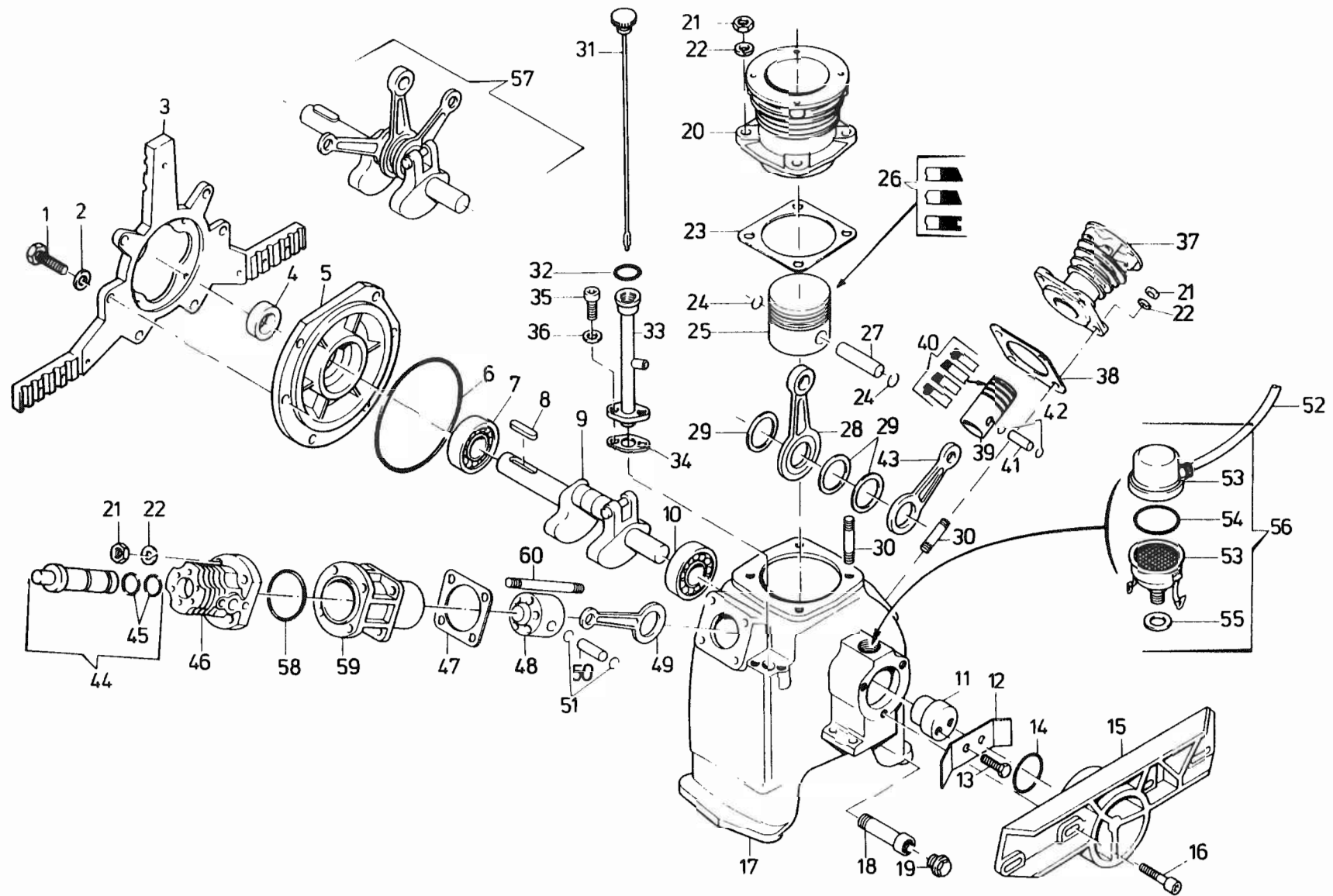



Ersatzteilsätze
Spare parts sets
Kits de pièces dét.

Bildtafel
Figure
Planche

TU-1 Kurbelgehäuse mit Zubehör, Friebwerk, Kolben und Zylinder
TU-1 Crankcase with accessories, driving gear, pistons and cylinders
TU-1 Carter avec équipements, embiellage, pistons et cylindres

Klasse Class Classe			Pos.	Bestell-Nr. Part No. No. de cde.	Benennung	Designation	Dénomination	Gewicht Weight Poids (kg)	Abmessungen Dimensions Dimensions
0	2	5							
1			1	45 N 2507	O-Ring	O-ring	Joint torique	0.005	∅ 18,77 x 1,78
				46 56352-060	Zylinder-Oberteil	Cylinder, upper	Cylindre, partie supérieure	0.500	
				47 1866-090	Dichtung	Gasket	Joint	0.001	∅ 45
				48 N 823	Führungskolben	Guide piston	Piston guide	0.110	
				49 1509-040	Pleuel 3. Stufe	Piston-rod 3rd stage	Bielle 3e étage	0.190	
				50	Kolbenbolzen	Piston pin	Boulon de piston		
				51	Sicherungsring	Snap ring	Anneau d'arrêt		
				52 N 3736	Schlauch*	Hose*	Tuyau*	0.165	Lw 6 x 1 x 200 lg.
				53 N 3207	Dämpferfilter	Demister body	Désaérateur	0.170	
				54 N 3712	O-Ring	O-ring	Joint torique	0.005	∅ 63,22 x 1,78
				55 N 293	Dichtring	Gasket	Joint	0.002	C 21x28x2 DIN 7603
				56 014892-635	Kurbelgehäuse-Entlüfter	Demister assy	Désaérateur cpl.	0.172	A 21x28
				57 013987-010	Triebwerk kpl.	Driving gear cpl.	Embiellage cpl.	2.400	
				58 N 4064	O-Ring	O-ring	Joint torique	0.005	∅ 50 x 2
				59 56141-060	Zylinder-Unterteil	Cylinder, lower	Cylindre partie inférieure	0.800	
				60 N 4065	Stiftschraube	Stud	Goujon fileté	0.060	M 8x70 DIN 835
					* Länge bei Bestellung angeben	* Indicate length when ordering	* Indiquer longueur en cas de commande		

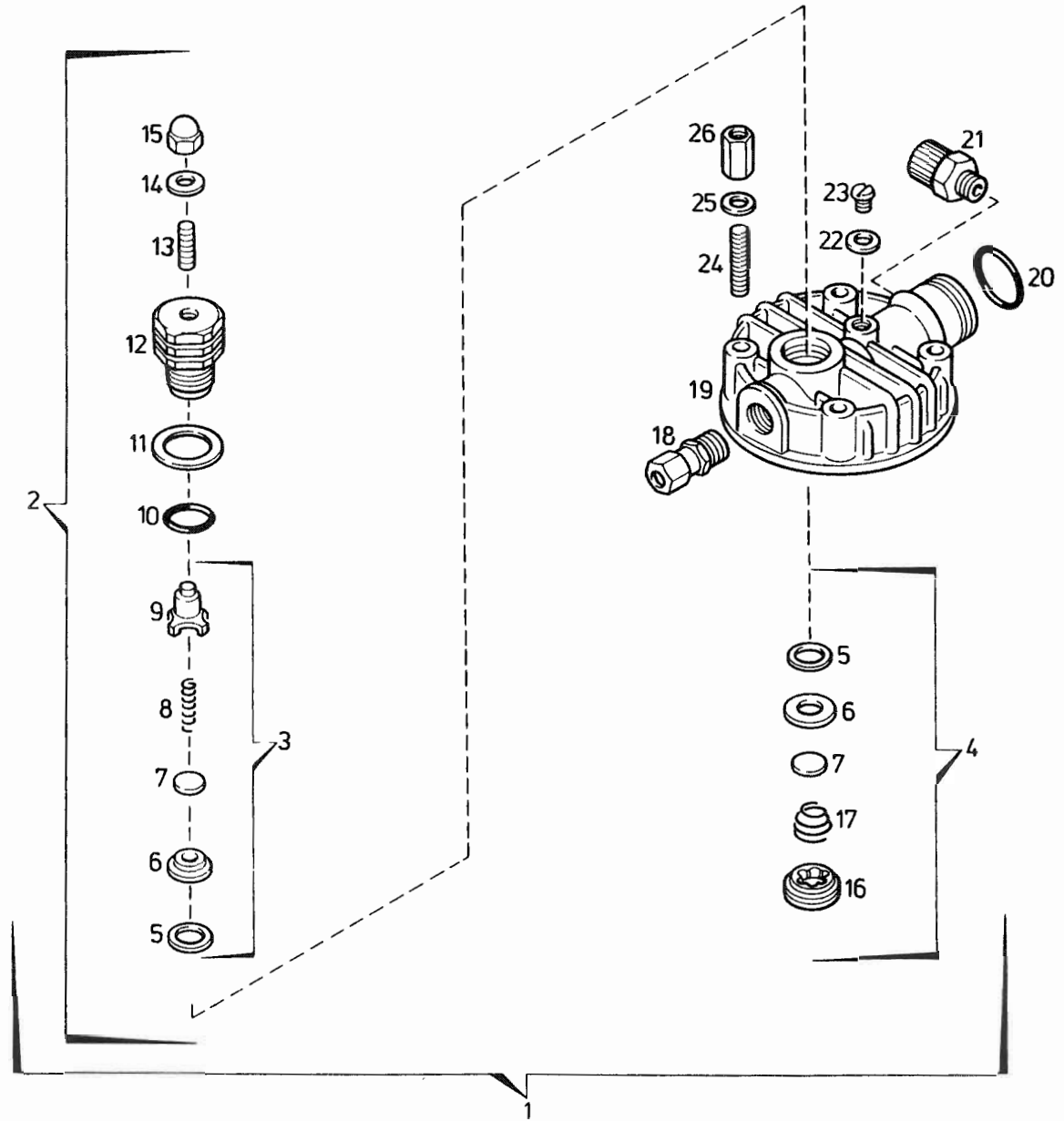



Ersatzteilsätze
Spare parts sets
Kits de pièces dét.

Bildtafel TU-2 Ventilkopf 1. Stufe
Figure TU-2 Valve head 1st stage
Planche TU-2 Culasse de 1er étage

Klasse Class Classe			Pos.	Bestell-Nr. Part No. No. de cde.	Benennung	Designation	Dénomination	Gewicht Weight Poids (kg)	Abmessungen Dimensions Dimensions
0	2	5							
			1	014910-070	Ventilkopf 1. Stufe kpl.	Valve head assy 1st stage	Culasse de 1er étage cpl.	1.000	
			2	014583-080	Druckventil kpl.	Discharge valve assy	Clapet de refoulement cpl.	0.185	
	1		3	012840-080	Druckventileinsatz kpl.	Discharge valve insert assy	Garniture clapet de refoulem.	0.028	
			4	012841-080	Saugventil	Intake valve	Clapet d'aspiration	0.035	
1			5		Dichtung	Gasket	Joint	0.001	
			6		Ventilsitz	Valve seat	Siège de soupape	0.006	
			7		Ventilplatte	Valve plate	Plaque de soupape	0.002	
			8		Druckfeder	Spring	Ressort de pression	0.001	
			9		Druckventileinsatz	Discharge valve insert	Garniture clapet de refoulem.	0.018	
1	1	2	10	N 3521	O-Ring	O-ring	Joint torique	0.005	Ø 21.82x3.53
			11	14332-080	Tellerfeder	Spring plate	Ressort à disque	0.003	
			12	14124-080	Verschraubung	Plug	Bouchon	0.127	
			13	N 3520	Gewindestift	Stud	Goupille filetée	0.010	AM 8x25 DIN 913
		2	14	N 380	Dichtring	Gasket	Joint	0.001	C 8x14x1.5 DIN 7603
			15	N 84	Hutmutter	Acorn nut	Ecrou à chapeau	0.010	M 8 DIN 1587
			16		Ventilverschraubung	Inlet valve cover	Bouchon de soupape	0.026	
1	1	3	17		Druckfeder	Spring	Ressort de pression	0.001	
			18	N 3418	Gerade Rohrverschraubung	Male connector	Raccord droit mâle	0.060	GE 12 PLR, Keg. 1/4"
			19	14911-070	Ventilkopf	Valve head	Culasse	0.400	
1	1	2	20	N 1539	O-Ring	O-ring	Joint torique	0.005	Ø 30.3 x 2.4
			21	N 3737	Kunststoffverschraubung	Plastic connector	Raccord plastique	0.010	EG 8 x 1, R 1/4"
			22	N 2714	Dichtring	Gasket	Joint	0.001	C 6.5x9.5x1.5 DIN 7603
			23	N 730	Zylinderschraube	Screw	Vis à tête cylindrique	0.030	M 6x10 DIN 84
			24	N 3507	Stiftschraube	Stud	Goujon fileté	0.025	M 8x40
			25	N 58	Scheibe	Washer	Rondelle	0.005	Ø 8.4 DIN 125
			26	5290-080	Verlängerungsmutter	Hex. extension	Ecrou de rallonge	0.025	

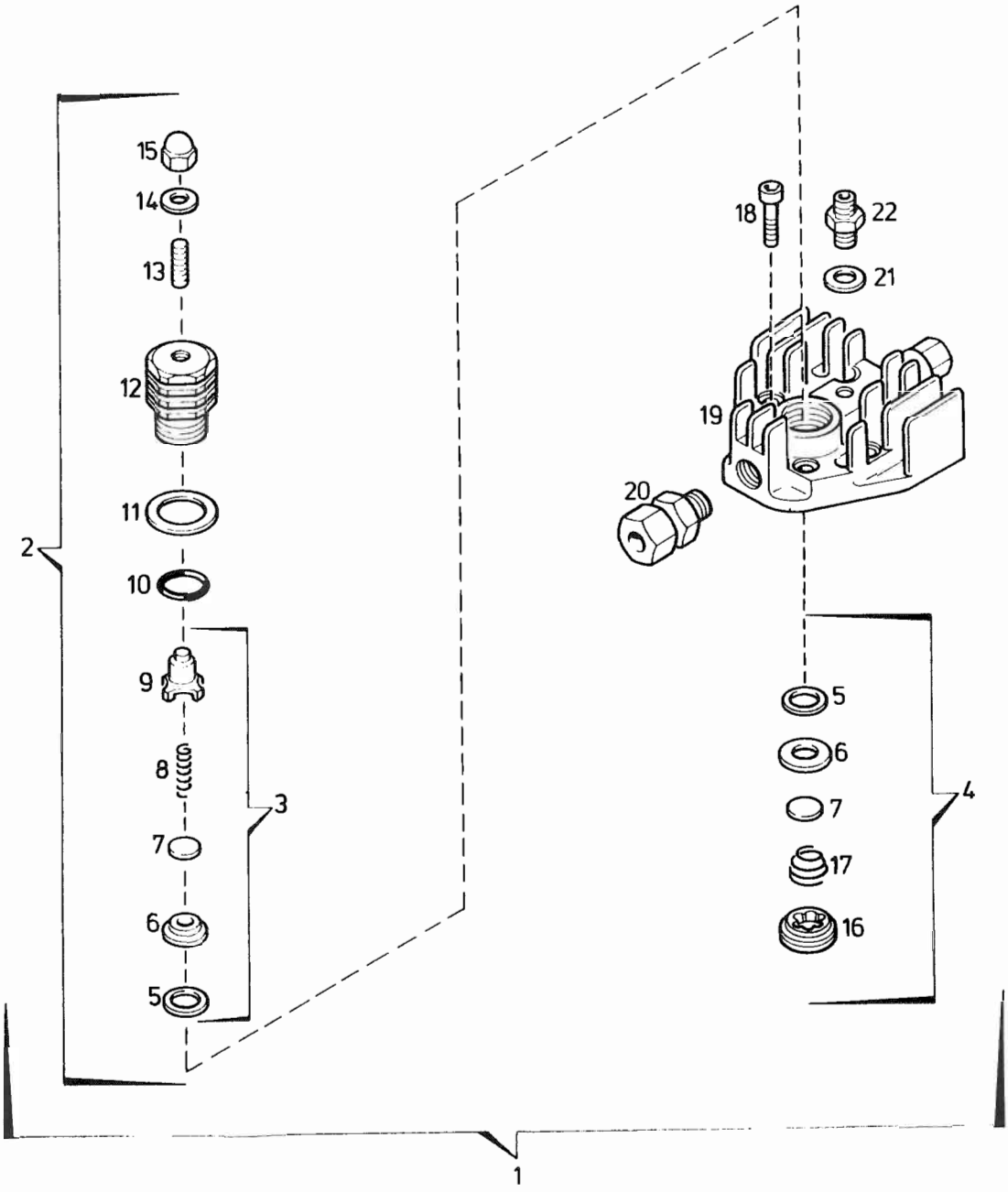



Ersatzteilsätze
Spare parts sets
Kits de pièces dét.

Bildtafel TU-3 Ventilkopf 2. Stufe
Figure TU-3 Valve head 2nd stage
Planche TU-3 Culasse de 2e étage

Klasse Class Classe			Pos.	Bestell-Nr. Part No. No. de cde.	Benennung	Designation	Dénomination	Gewicht Weight Poids (kg)	Abmessungen Dimensions Dimensions
0	2	5							
			1	014085-070	Ventilkopf 2. Stufe kpl.	Valve head assy 2nd stage	Culasse cpl. de 2e étage	0.850	
			2	014582-080	Druckventil kpl.	Discharge valve assy	Clapet de refoulement cpl.	0.185	
	1		2	3	012835-080	Druckventileinsatz kpl.	Garniture clapet de refoulem.	0.028	
			4	012836-080	Saugventil kpl.	Intake valve assy	Clapet d'aspiration cpl.		
			5		Dichtung	Gasket	Joint	0.001	
			6		Ventilsitz	Valve seat	Siège de soupape	0.006	
			7		Ventilplatte	Valve plate	Plaque de soupape	0.002	
			8		Druckfeder	Spring	Ressort de pression	0.001	
			9		Druckventileinsatz	Discharge valve insert	Garniture clapet de refoulem.	0.018	
1	1	2	10	N 3521	O-Ring	O-ring	Joint torique	0.005	∅ 21,82 x 3,53
			11	14332-080	Tellerfeder	Spring plate	Ressort à disque	0.003	
			12	14124-080	Verschraubung	Plug	Bouchon	0.127	
			13	N 3520	Gewindestift	Stud	Goupille fileté	0.010	AM 8 x 25 DIN 913
1	1	2	14	N 380	Dichtring	Gasket	Joint	0.001	C 8x14x1,5 DIN 7603
			15	N 84	Hutmutter	Acorn nut	Ecrou à chapeau	0.010	M 8 DIN 1587
1	1	3	16		Saugventilverschraubung	Inlet valve cover	Bouchon clapet d'aspiration	0.878	
1	3		17		Druckfeder	Inlet valve spring	Ressort de pression	0.001	
			18	N 503	Innensechskantschraube	Allen screw	Vis six pans creux	0.018	M 8x35 DIN 912
			19	14123-070	Ventilkopf, 2. Stufe	Valve head, 2nd stage	Culasse de 2e étage	0.490	
			20	N 7838	Gerade Rohrverschraubung	Male connector	Raccord droit mâle	0.040	GE 12-LLR, R 1/4"
			21	N 1316	Dichtring	Gasket	Joint	0.002	A 13 x 20 DIN 7603
			22	N 3504	Gerade Rohrverschraubung	Male connector	Raccord droit mâle	0.050	GE 8-SR, zyl.



Ersatzteilsätze
Spare parts sets
Kits de pièces det.

Bildtafel TU-4 Ventilkopf 3. Stufe
Figure TU-4 Valve head 3rd stage
Planche TU-4 Culasse de 3e étage

Klasse Class Classe			Pos.	Bestell-Nr. Part No. No. de cde.	Benennung	Designation	Dénomination	Gewicht Weight Poids (kg)	Abmessungen Dimensions Dimensions
0	2	5							
1	1	3	1	07790-080	Saugventil	Intake valve	Clapet d'aspiration	0.007	.. Ø 15,6 x 1,78 AM 8x1x25 DIN 913 A 8x14x1,5 DIN 7603 M 8x1 DIN 917 M 8x60 DIN 912 GE 12 LLR, R 1/4" A 13x20 DIN 7603 d 8-5 m 8-5
			2	14117-070	Ventilkopf	Valve head	Culasse	0.300	
			3	014121-080	Druckventil	Discharge valve	Clapet de refoulement	0.020	
			4	N 2789	O-Ring	O-ring	Joint torique	0.005	
			5	14118-070	Ventilkopfdeckel	Valve head cover	Couvercle de culasse	0.207	
			6	N 3624	Gewindestift	Stud	Goupille filetée	0.010	
			7	N 3625	Dichtung	Gasket	Joint	0.001	
			8	N 3623	Hutmutter	Acorn nut	Ecrou chapeau	0.010	
			9	N 150	Innensechskantschraube	Allen screw	Vis six pans creux	0.045	
			10	N 7838	Gerade Rohrverschraubung	Male connector	Raccord droit mâle	0.040	
			11	N 1316	Dichtring	Gasket	Joint	0.001	
			12	57788-635	Zwischenstück	Adapter	Connexion	0.070	
			13	N 3609	Schneidring	Compression ring	Anneau de matrice	0.005	
			14	N 3608	Überwurfmutter	Coupling nut	Ecrou-raccord	0.020	
			15	057057-070	Ventilkopf 3. Stufe kpl.	Valve head assy. 3rd stage	Culasse cpl. de 3e étage	0.645	

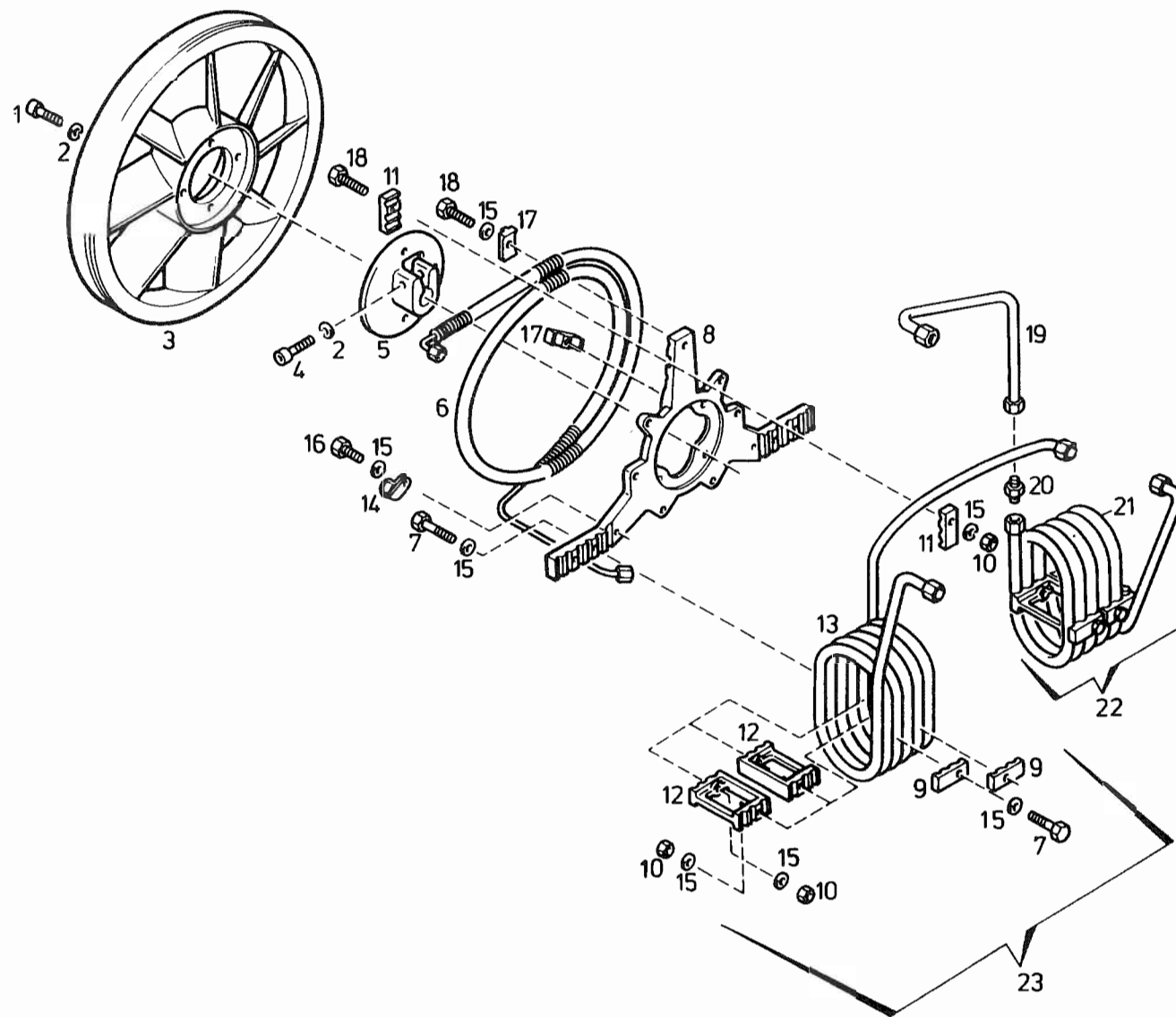



Ersatzteilsätze
Spare parts sets
Kits de pièces dét.

Bildtafel TU-5 Kühler und Ventilator
Figure TU-5 Cooler and fan
Planche TU-5 Refroidisseur et ventilateur

Klasse Class Classe			Pos.	Bestell-Nr Part No. No. de cde.	Benennung	Designation	Dénomination	Gewicht Weight Poids (kg)	Abmessungen Dimensions Dimensions	
0	2	5								
			1	N 171	Innensechskantschraube	Allen screw	Vis six pans creux	0.020	M 8x20	DIN 912
			2	N 108	Federring	Lock washer	Rondelle élastique	0.005	A 8	DIN 127
			3	13623-110	Ventilatorrad	Fan	Rotor	3.190	Ø 400	
			4	N 1437	Innensechskantschraube	Allen screw	Vis six pans creux	0.030	M 8x45	DIN 912
			5	13666-110	Ventilatorradnabe	Fan hub	Moyeu	1.010		
			6	58310-500	Nachkühler	Aftercooler	Refroidisseur final	0.875		
			7	N 3498	Sechskantschraube	Hex. screw	Vis six pans	0.020	M 6x45	DIN 933
			8	14998-860	Kühlrohrhalterung	Bracket for cooler	Fixation de refroidisseur	0.695		
			9	13662-500	Kühlrohrfixierstück	Fixing for cooler	Fixation de refroidisseur	0.020		
			10	N 1042	Sechskantmutter, sebsts.	Hex. nut, self-locking	Ecrou, auto-freinant	0.005	NM 6	DIN 980
			11	14564-500	Kühlrohrfixierstück	Fixing for cooler	Fixation de refroidisseur	0.020		
			12	13663-500	Zwischenstück	Intermediate piece	Pièce intermédiaire	0.065		
			13		Kühlrohrspirale 2. Stufe	Cooler 2nd stage	Refroidisseur 2e étage	0.550		
			14	14370-500	Rohrschelle	Pipe clamp	Collier pour tuyaux	0.017		
			15	N 102	Scheibe	Washer	Rondelle	0.005	Ø 6.4	DIN 125
			16	N 101	Sechskantschraube	Hex. screw	Vis six pans	0.010	M 6x20	DIN 933
			17	14139-500	Klemmstück	Clamp	Pièce de serrage	0.017		
			18	N 3531	Sechskantschraube	Hex. screw	Vis six pans	0.010	M 6x40	DIN 933
			19	14901-500	Verbindungsleitung	Connecting tube	Tube de connexion	0.125		
			20	N 3464	Gerade Rohrverschraubung	Male connector	Raccord droit mâle	0.042	G 12-LL	
			21		Kühlrohrspirale 1. Stufe	Cooler 1st stage	Refroidisseur 1er étage	0.465		
			22	014624-500	Zwischenkühler 1. Stufe	Intercooler 1 st stage	Refroidisseur intermédiaire 1er étage	0.535		
			23	058991-500	Zwischenkühler 2. Stufe	Intercooler 2nd stage	Refroidisseur intermédiaire 2e étage	0.720		

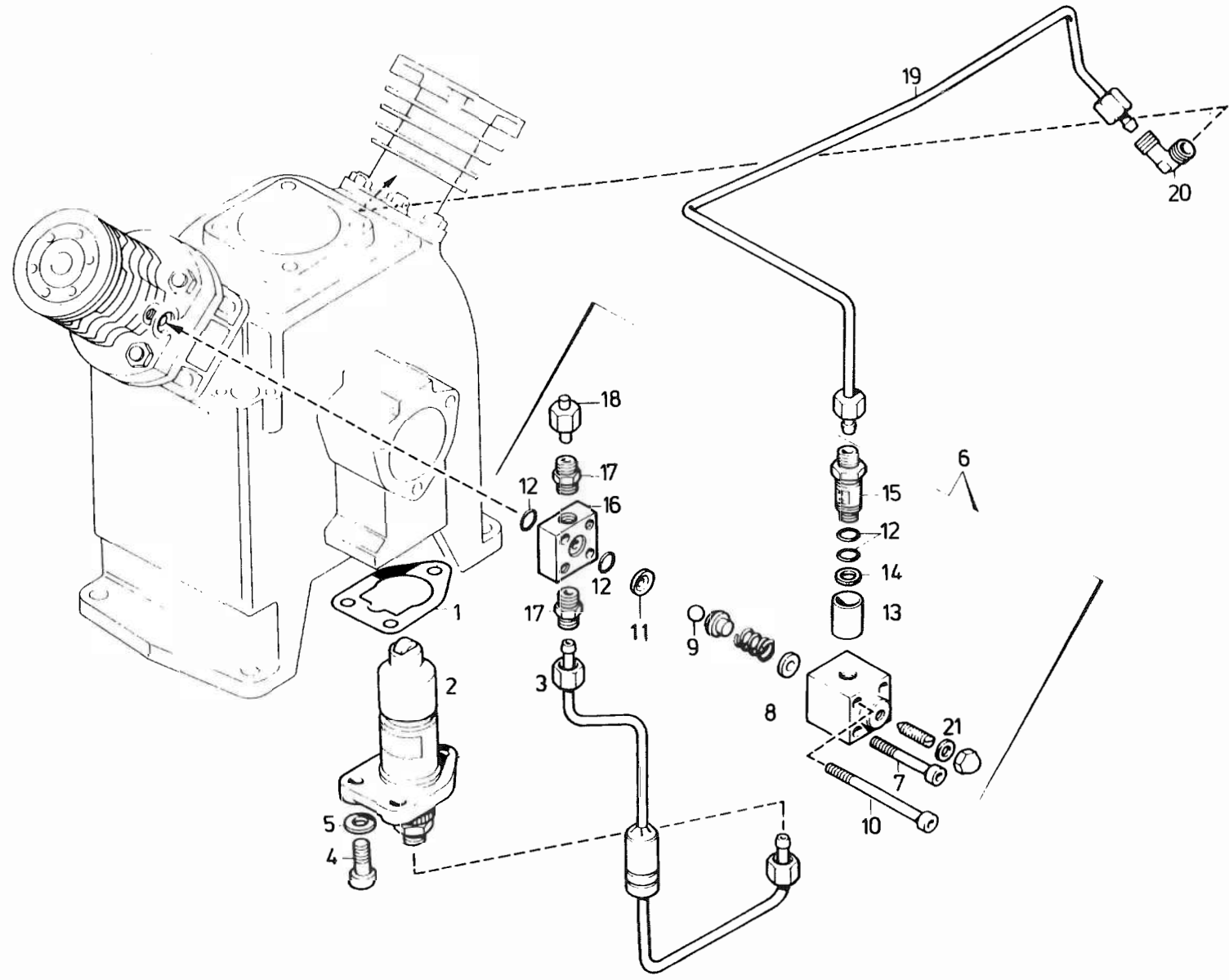



Ersatzteilsätze
Spare parts sets
Kits de pièces dét.

Bildtafel TU-6 Öldruckschmierung
Figure TU-6 Lubrication
Planche TU-6 Lubrification

Klasse Class Classe			Pos.	Bestell-Nr Part No. No. de cde.	Benennung	Designation	Dénomination	Gewicht Weight Poids (kg)	Abmessungen Dimensions Dimensions				
0	2	5											
1			1	2010-90	Dichtung	Gasket	Joint	0.001					
			1	N 83	Ölpumpe	Oil pump	Pompe à huile	0.810					
			1	57150-650	Druckölleitung	Oil supply tube	Tube d'huile sous pression	0.105					
				N 61	Innensechskantschraube	Allen screw	Vis six pans creux	0.015	M 8x25	DIN 912			
				N 58	Scheibe	Washer	Rondelle	0.005	Ø 8.4	DIN 125			
			1	058138-341	Öldruckreguliertventil	Oil pressure regulating valve	Soupape régulatrice de pression d'huile	0.280					
				N 781	Innensechskantschraube	Allen screw	Vis six pans creux	0.015	M 6x60	DIN 912			
				58102-341	Öldruckreguliertventilgehäuse	Housing for oil pressure regulating valve	Corps de soupape régulatrice de pression d'huile	0.120					
			1	2	9	N 2768	Kugel	Ball	Bille	0.005	Ø 8		
					10	N 3407	Innensechskantschraube	Allen screw	Vis six pans creux	0.020	M 6x80	DIN 912	
			1	2	11	58119-341	Kugelventilsitzplatte	Seat of ball valve	Plaque d'appui de soupape sphérique	0.010			
			4	2	2	12	N 7091	O-Ring	O-ring	Joint torrique	0.001	Ø 9,25x1,78	
			1	1	2	13	56302-635	Ölschauglas	Oil gauge glass	Indicateur de niveau d'huile	0.003		
						14	N 4051	Dichtring	Gasket	Joint	0.005	A 10x15	DIN 7603
						15	56301-635	Ölkontrollverschraubung	Oil level check union	Boulonnage de contrôle d'huile	0.010		
						16	57132-341	Öldruckreguliertventilflansch	Flange for oil pressure regulating valve	Collet de soupape régulatrice de pression d'huile	0.048		
						17	N 4140	Gerade Rohrverschraubung	Male connector	Raccord droit mâle	0.013	GE 6-LLR ed	
						18	N 4530	Verschlußstopfen	Plug	Bouchon	0.015		
						19	57151-650	Ölrücklaufleitung	Oil return tube	Tube de retour d'huile			
						20	N 1057	Winkel-Rohrverschraubung	Male elbow	Raccord mâle coudé	0.035	WE 6-LR	
						21	N 380	Dichtring	Gasket	Joint	0.001	8x14x1.5	

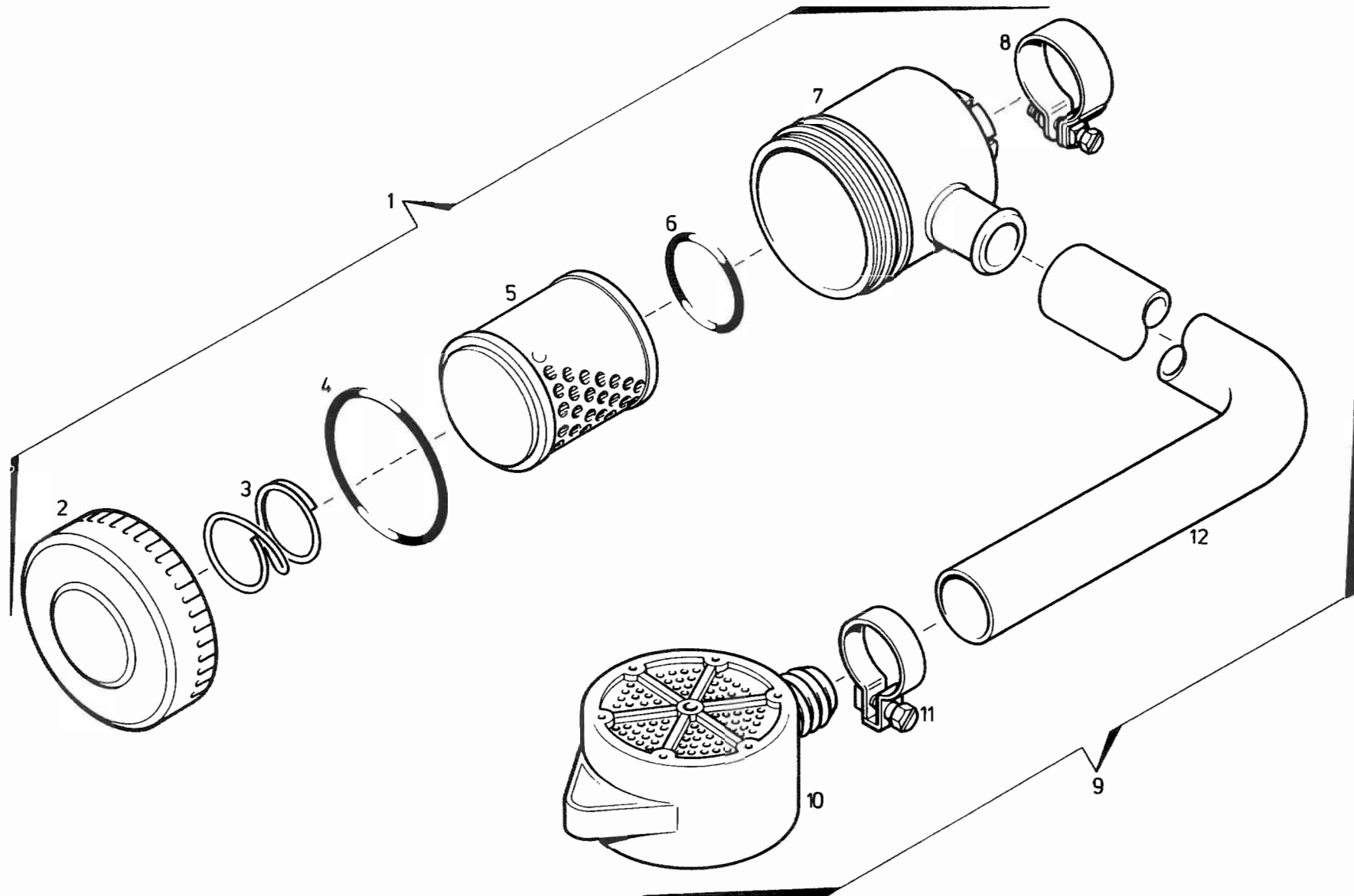



Ersatzteilsätze
Spare parts sets
Kits de pièces dét.

Bildtafel TU-7 Ansaugfilter mit Ansaugschlauch
Figure TU-7 Intake filter with intake hose
Planche TU-7 Filtre d'aspiration avec tuyau d'aspiration

Klasse Class Classe			Pos.	Bestell-Nr. Part No. No. de cde.	Benennung	Designation	Dénomination	Gewicht Weight Poids (kg)	Abmessungen Dimensions Dimensions
0	2	5							
	1	4	1	013758-400	Ansaugfilter	Intake filter assy	Filtre d'aspiration	0.340	
			2	12771-400	Ansaugfilterdeckel	Intake filter cover	Couvercle du filtre d'aspir.	0.080	
			3	10528-640	Druckfeder	Spring	Ressort de pression	0.008	
1	1	2	4	N 4451	O-Ring	O-ring	Joint torique	0.010	∅ 75 x 3
			5	N 70	Filtereinsatz	Filter element	Élément filtrant	0.070	
1	1	2	6	13757-090	O-Ring	O-ring	Joint torique	0.005	∅ 35 x 5
			7	12770-400	Ansaugfiltergehäuse	Intake filter housing	Boîtier du filtre d'aspir.	0.150	
			8	N 3374	Rohrschelle	Clamp	Collier pour tuyaux	0.020	
			9	014539-400	Ansaugschlauch kpl. mit Filter	Intake hose assy with filter	Tuyau d'aspiration avec filtre	0.800	
			10	057691-400	Vorfilter	Pre-filter	Premier filtre	0.115	
			11	N 2011	Schlauchklemme	Hose clamp	Collier pour tuyaux	0.005	Nr. 38, ∅ 28-30
			12	N 1005	Ansaugschlauch	Intake hose	Tuyau d'aspiration	0.680	

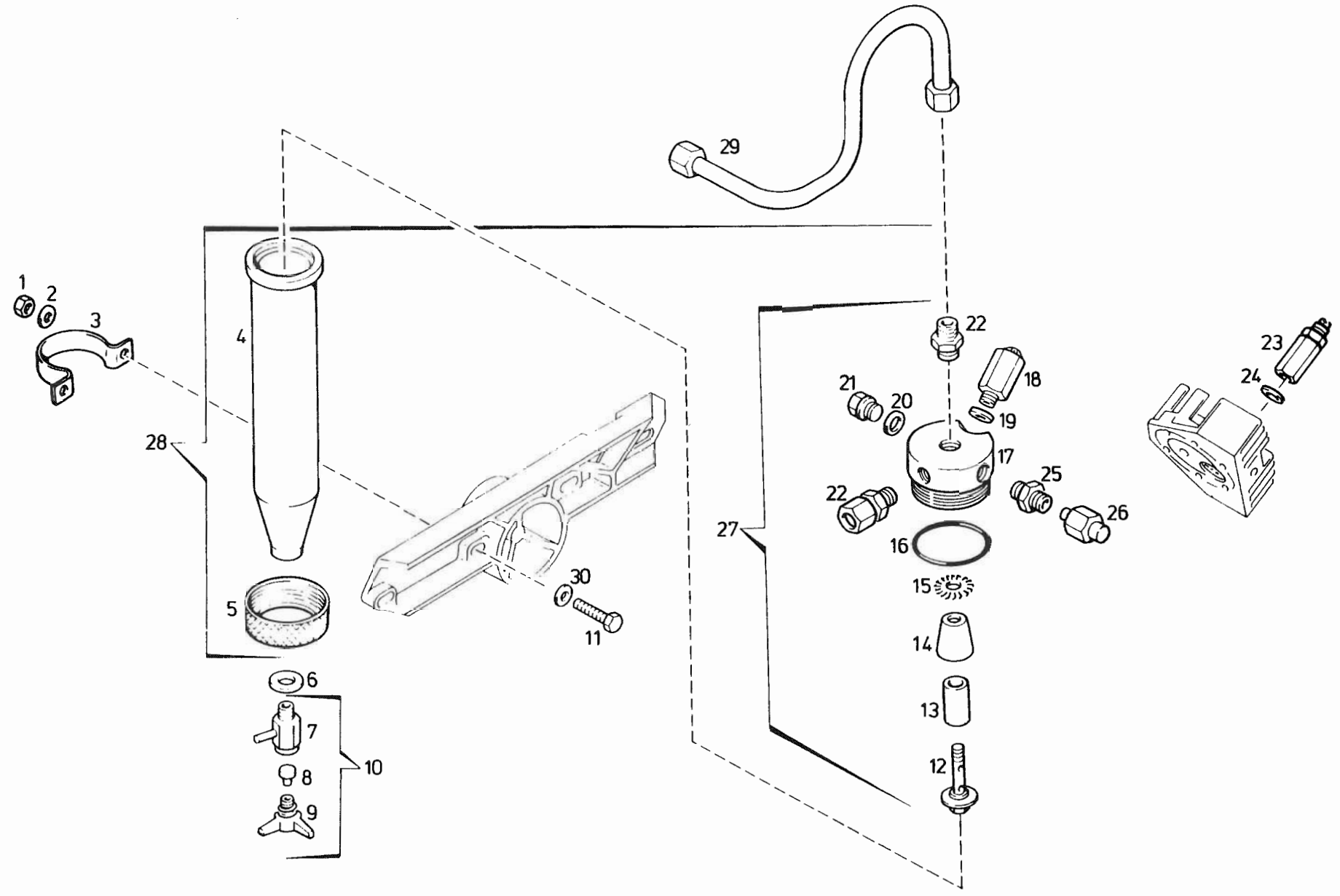



Ersatzteilsätze
Spare parts sets
Kits de pieces dét.

Bildtafel TU-8 Zwischenfilter
Figure TU-8 Interfilter
Planche TU-8 Filtre intermédiaire

Klasse Class Classe			Pos.	Bestell-Nr. Part No. No. de cde.	Benennung	Designation	Dénomination	Gewicht Weight Poids (kg)	Abmessungen Dimensions Dimensions	
0	2	5								
			1	N 57	Sechskantmutter	Hex. nut	Ecrou hex.	0.008	M 8	DIN 934
			2	N 2862	Scheibe	Washer	Rondelle	0.007	Ø 8,4	DIN 7349
			3	14368-655	Rohrschelle	Clamp	Collier pour tuyaux	0.125		
			4	14150-430	Filtergehäuse	Filter housing	Corps de filtre	0.300		
			5	13937-430	Überwurfmutter	Threaded collar	Ecrou-chapeau	0.130		
			6	N 1316	Dichtung	Gasket	Joint	0.005	A 13x20	DIN 7603
			7	2371-635	Ablabhahnkörper	Drain tap housing	Corps de robinet de purge	0.055		
			8	13283-090	Dichtung	Gasket	Joint	0.001		
			9	055888-635	Knebelschraube mit Sicherungsf.	Tap screw with spring	Manette avec ressort	0.020		
			10	011430-635	Kondensatablahahn	Condensate drain tap	Robinet de purge cpl.	0.075		
			11	N 89	Sechskantschraube	Hex. screw	Vis six pans	0.020	M 8x30	DIN 933
			12	12786-430	Mittelschraube	Screw	Vis centrale	0.006		
	1	2	13	N 2726	Filtereinsatz	Filter element	Elément filtrant	0.015		
			14	12785-430	Pralltrichter	Baffle cone	Cône de dispersion	0.003		
			15	12784-430	Verteilerblech	Vortex plate	Diffuseur	0.001		
1		1	16	N 3556	O-Ring	O-ring	Joint torique	0.005	Ø 45 x 2	
			17	13930-430	Filterkopf	Filter head	Tête de filtre	0.185		
			18	011656-340	Sicherheitsventil 2. Stufe	Safety valve 2nd stage	Soupape de sécurité 2e étage	0.058	50 bar	
	1		19	4479-090	Dichtung	Gasket	Joint	0.001		
			20	N 4051	Dichtung	Gasket	Joint	0.005	A 10x15	DIN 7603
			21	N 3459	Verschlußschraube	Plug	Bouchon	0.060	R 1/8"	DIN 910
			22	N 7838	Gerade Rohrverschraubung	Male connector	Raccord droit mâle	0.040	GE 12 LLR, R 1/4"	
			23	010670-340	Sicherheitsventil 2. Stufe	Safety valve 2nd stage	Soupape de sécurité 2e étage	0.065	8 bar	
1			24	8264-090	Dichtung	Gasket	Joint	0.001		
			25	N 1051	Gerade Rohrverschraubung	Male connector	Raccord droit mâle	0.025	GE 6-LR	
			26	N 4530	Verschlußstopfen	Plug	Bouchon	0.015		
			27	014151-430	Filterkopf kpl.	Filter head assy	Tête de filtre cpl.	0.350		
			28	014427-430	Zwischenfilter kpl.	Interfilter assy	Filtre intermédiaire cpl.	0.820		
			29	58249-500	Verbindungsleitung	Connecting tube	Tube de connexion	0.072		
			30	N 58	Scheibe	Washer	Rondelle	0.005	Ø 8,4	DIN 125

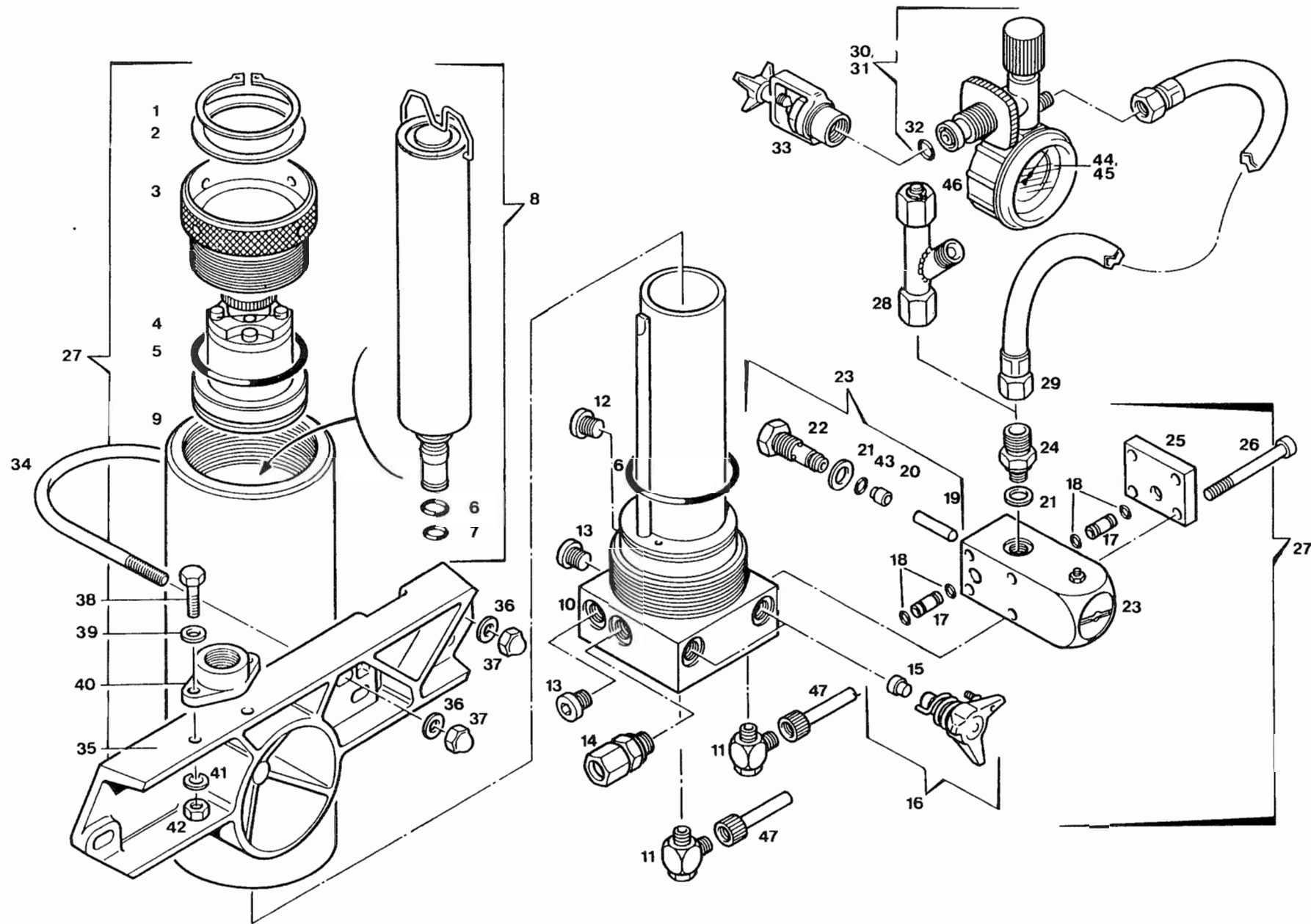



Ersatzteilsätze
Spare parts sets
Kits de pièces dét.

Bildtafel TU-9 Filtersystem P21 mit Fülleinrichtung
Figure TU-9 Filter system P21 with filling device
Planche TU-9 Système de filtrage P21 avec dispositif de remplissage

Klasse Class Classe			Pos.	Bestell-Nr. Part No. No. de cde.	Benennung	Designation	Dénomination	Gewicht Weight Poids (kg)	Abmessungen Dimensions Dimensions
0	2	5							
	1	1	1	N 15598	Sicherungsring	Snap ring	Anneau d'arrêt	0,005	55 x 2 DIN 471
	1	1	2	63438-410	Gleitring	Slide ring	Anneau de glissement	0,010	
			3	61711-340	Verschraubung	Plug	Bouchon		
		1	4	061114-340	Sicherheitsventil*	Safety valve*	Soupape de sécurité*	0,500	100 - 350 bar
2	2	2	5	N 4586	O-Ring	O-ring	Joint torique	0,050	Ø 59,92 x 3,53
1			6	N 4566	O-Ring	O-ring	Joint torique	0,050	Ø 9,19 x 2,62
1			7	N 3824	O-Ring	O-ring	Joint torique	0,050	Ø 7,59 x 2,62
			8	057679-410	Triplexpatrone	Triplex cartridge	Cartouche triplex	0,300	
			9	57682-410	Filtergehäuse	Filter housing	Corps de filtre		
			10	065307-410	Filterboden kpl.	Filter bottom assy.	Fond de filtre cpl.		
1			11	N 16334	L-Schnellverschraubung	Male run T connector	Raccord en T renversé		
			12	N 16954	Verschlußschraube	Plug	Bouchon	0,015	vsti R 1/8" -ed
2			13	N 16394	Verschlußschraube	Plug	Bouchon	0,020	vsti R 1/4" -ed
			14	N 4687	Gerade Rohrverschraubung	Male connector	Raccord droit mâle		GE 8 PSR -ed
1	3	5	15	64498-635	Dichtung	Gasket	Joint	0,005	
		1	16	065500-635	Knebelschraube kpl.	Condensate drain tap assy.	Robinet de purge cpl.	0,090	
			17	57904-410	Verbindungsrohr	Connection pipe	Tuyau de connexion		
4	2	2	18	N 16591	O-Ring	O-ring	Joint torique	0,005	Ø 5 x 1,5
2			19	066112-341	Druckstift kpl.	Pressure pin assy.	Cheville de pression cpl.		
	1	2	20	57735-341	Ventilkolben	Valve piston	Clapet	0,040	
1	2	2	21	N 4602	USIT-Ring	USIT-ring	Joint	0,020	U 14-18.7-1.5
		1	22	57741-341	Druckhalteventilsitz	Pressure maintaining valve seat	Siège de la soupape de maintien de pression	0,025	
		1	23	058037-341	Druckhalteventil	Pressure maintaining valve	Soupape de maintien de press.	0,040	
			24	58036-635	Schlauchnippel	Hose connection	Raccord de flexible		
			25	57937-341	Abschlußdeckel	Cover	Couvercle		
			26	N 781	Innensechskantschraube	Allen screw	Vis six pans creux		M 6 x 60 DIN 912
			27	062211-410	Zentralfilter o. Patrone	Central filter assy w/o cartridge	Filtre central sans cartouche		
			28	014532-635	Verteiler	Distributor	Distributeur		
	1		29	N 2817	Füllschlauch	Filling hose	Tuyau de remplissage	0,600	NW 6x1 m lg.
	1		30	060483-635	Füllventil	Filling valve	Robinèt de remplissage	0,740	200 bar
	1		31	060482-635	Füllventil	Filling valve	Robinèt de remplissage	0,740	300 bar
			32	N 638	O-Ring	O-ring	Joint torique	0,005	Ø 11 x 2,5
1			33	08487-635	Internationaler Füllanschluß	International connection	Raccord international		200 bar
			34	58165-635	Befestigungsbügel	U-bolt	Etrier de fixation		
			35	58159-860	Filterhalterung	Filter mounting	Support de filtre		
			36	N 2862	Scheibe	Washer	Rondelle		Ø 8,4 DIN 7349
			37	N 84	Hutmutter	Acorn nut	Ecrou borgne		M 8 DIN 1587

* Einstelldruck bei Bestellung angeben
** je nach Betriebsdruck

* Indicate adjusted pressure when ordering
** acc. to operating pressure

* Indiquez la pression d'ajustage en commandant
** selon pression de service

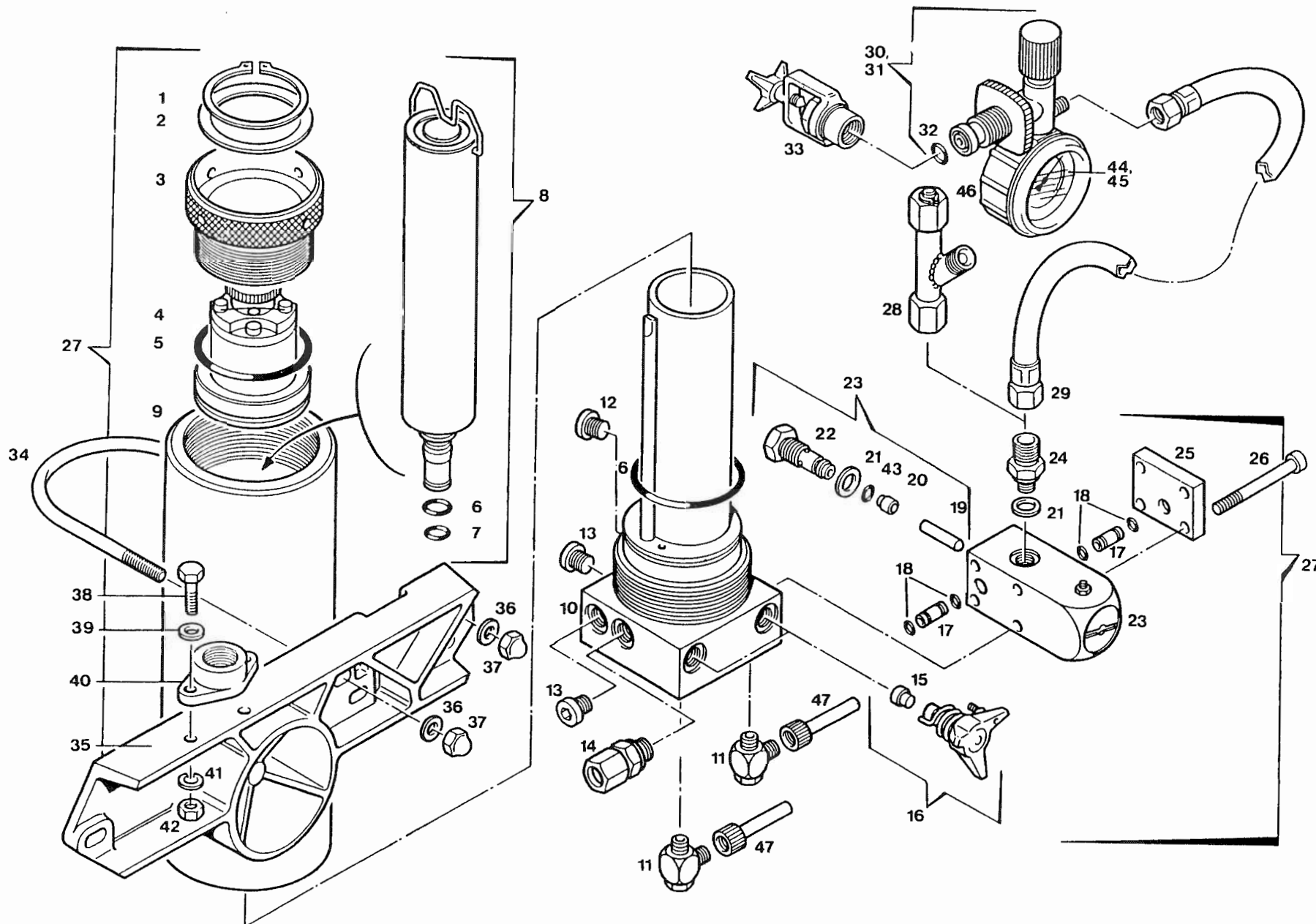



Ersatzteilsätze
Spare parts sets
Kits de pieces dét.

Bildtafel TU-9 Filtersystem P21 mit Fülleinrichtung
Figure TU-9 Filter system P21 with filling device
Planche TU-9 Système de filtrage P21 avec dispositif de remplissage

Klasse Class Classe			Pos.	Bestell-Nr. Part No. No. de cde.	Benennung	Designation	Dénomination	Gewicht Weight Poids (kg)	Abmessungen Dimensions Dimensions	
0	2	5								
			38	N 2900	Sechskantschraube	Hex. screw	Vis six pans		M 6 x 25	DIN 933
			39	N 102	Scheibe	Washer	Rondelle		Ø 6,4	DIN 125
			40	12731-635	Füllventilbefestigung	Filling valve mounting	Fixation soupape de rempliss.			
			41	N 100	Federring	Lock washer	Rondelle élastique		A 6	DIN 127
			42	N 287	Sechskantmutter	Hex. nut	Ecrou hex.		M 6	DIN 934
			43	N 16554	O-Ring	O-ring	Joint torique		Ø 6x1,5	
1	1		44	N 1315	Manometer**	Pressure gauge**	Manomètre**	0,200	200 bar	
1	1		45	N 4101	Manometer**	Pressure gauge**	Manomètre**	0,200	300 bar	
1	1		46	N 2876	Schutzkappe	Protection cap	Capot de protection			
			47	N 17073	Schlauch***	Hose***	Tuyau flex.***			
1		4		060399-635	Reparaturatz f. Füllventil	Repair kit for filling valve	Kit de réparation pour robinet de remplissage	0,100		

* Einstelldruck bei Bestellung angeben
** je nach Betriebsdruck
*** Länge nach Bestellung

* Indicate adjusted pressure when ordering
** acc. to operating pressure
*** Length on order

* Indiquez la pression d'ajustage en commandant
** selon pression de service
*** Longueur selon commande

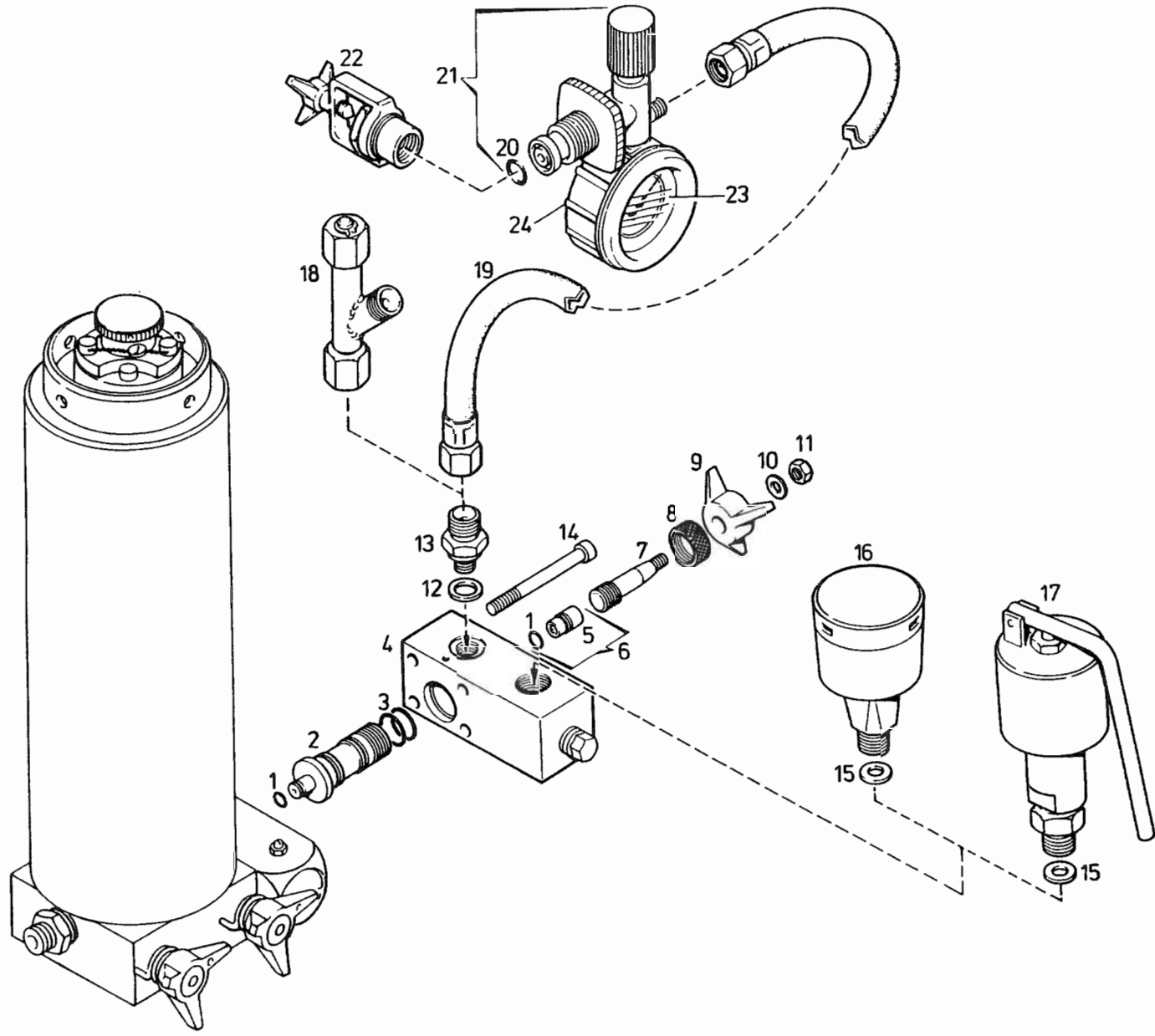



Ersatzteilsätze
Spare parts sets
Kits de pieces det.

Bildtafel TU-10 Umschalteinrichtung PN 200/PN 300 für Filtersystem P21
Figure TU-10 Change over device 3200/4700 psi for filter system P21
Planche TU-10 Dispositif sélecteur PN 200/PN 300 pour système de filtrage P21

Klasse Class Classe			Pos.	Bestell-Nr. Part No No de cde.	Benennung	Designation	Dénomination	Gewicht Weight Poids (kg)	Abmessungen Dimensions Dimensions
0	2	5							
1	1	2	1	N 16591	O-Ring	O-ring	Joint torique	Ø 5 x 1,5	
			2	58030-635	Spindelaufnahme	Spindle carrier	Porte broche		
1	1	2	3	N 3405	O-Ring	O-ring	Joint torique	Ø 12,42 x 1,78	
			4	57701-635	Umschaltleiste	Switch over block	Bloc sélecteur		
			5	58178-635	Spindelkolben	Spindle piston	Piston		
	1	2	6	058229-635	Spindelkolben kpl.	Spindle piston assy.	Piston cpl.		
		1	7	58223-635	Spindel	Spindle	Broche		
			8	58032-635	Sicherungsmutter	Lock nut	Contre écrou		
		1	9	58228-635	Knebelgriff	Tap screw	Manette		
			10	N 2949	Scheibe	Washer	Rondelle	B 5,3 DIN 125	
			11	N 2488	Sechskantmutter, selbsts.	Hex. nut, self-locking	Ecrou hex., auto-freinant	NM 5 DIN 980	
1	1	2	12	N 4602	USIT-Ring	Gasket	Joint	U 14-18,7-1,5	
			13	58036-635	Schlauchnippel	Hose connection	Raccord de flexible		
			14	N 3407	Innensechskantschraube	Allen screw	Vis six pans creux	M 6 x 80 DIN 912	
1	1	2	15	4479-090	Dichtung	Gasket	Joint		
			16	03063-340	Sicherheitsventil*	Safety valve*	Soupape de sécurité*	200 bar	
			17	013497-340	Sicherheitsventil*	Safety valve*	Soupape de sécurité*	200 bar (TÜV)	
			18	014532-635	Verteiler	Distributor	Distributeur		
			19	N 2817	Füllschlauch	Filling hose	Tuyau de remplissage	NW 6 x 1 m lg.	
1	1	2	20	N 638	O-Ring	O-ring	Joint torique	Ø 11 x 2,5	
			21	060483-635	Füllventil	Filling valve	Soupape de remplissage		
			22	08487-635	Internationaler Flaschenanschluß	International connection	Raccord international		
			23	N 1315	Manometer	Pressure gauge	Manomètre	200 bar	
	1	1	24	N 2876	Schutzkappe	Protection cap	Capot de protection		

* Einstelldruck bei Bestellung angeben

* Indicate adjusted pressure when ordering

* Indiquez la pression d'ajustage en commandant

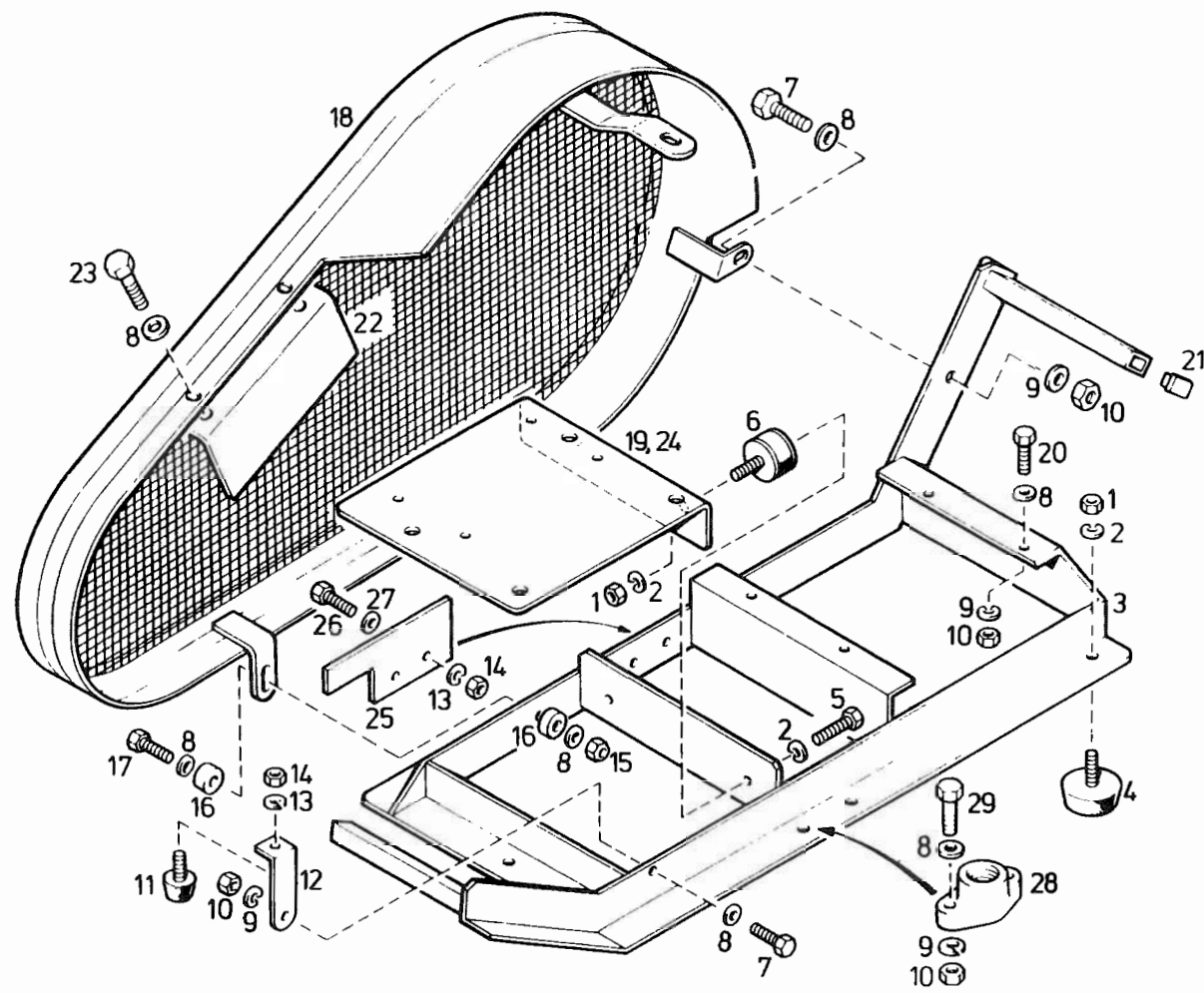



Ersatzteilsatz
Spare parts sets
Kits de pieces det.

Bildtafel TU-11 Grundrahmen
Figure TU-11 Base frame
Planche TU-11 Cadre de base

Klasse Class Classe			Pos	Bestell-Nr Part No No de cde.	Benennung	Jesignation	Dénomination	Gewicht Weight Poids (kg)	Abmessungen Dimensions Dimensions	
0	2	5								
			1	N 177	Sechskantmutter	Hex. nut	Ecrou hex.	0.015	M 10	DIN 934
			2	N 176	Federring	Lock washer	Rondelle élastique	0.005	A 10	DIN 127
			3	14344-760	Rahmen	Frame	Cadre			
			4	N 1547	Schwingmetall	Vibration isolator	Amortisseur de vibration	0.085	Ø 50x15	
			5	N 570	Sechskantschraube	Hex. screw	Vis six pans	0.020	M 10x16	DIN 933
			6	N 1649	Schwingmetall	Vibration isolator	Amortisseur de vibration	0.125	Ø 50 x 20	
			7	N 198	Sechskantschraube	Hex. screw	Vis six pans	0.018	M 8x20	DIN 933
			8	N 58	Scheibe	Washer	Rondelle	0.005	Ø 8,4	DIN 125
			9	N 108	Federring	Lock washer	Rondelle élastique	0.005	A 8	DIN 127
			10	N 57	Sechskantmutter	Hex. nut	Ecrou hex.	0.008	M 8	DIN 934
			11	N 1899	Anschlagpuffer	Vibration isolator	Amortisseur de vibration	0.015	U2B, U2B-H	
			12	14450-655	Anschlagwinkel	Stop angle	Angle de butée	0.050	U2B, U2B-H	
			13	N 100	Federring	Lock washer	Rondelle élastique	0.001	A 6	DIN 127
			14	N 287	Sechskantmutter	Hex. nut	Ecrou hex.	0.005	M 6	DIN 934
			15	N 370	Sechskantmutter, selbsts.	Hex. nut, self-locking	Ecrou hex., auto-freinant	0.009	NM 8	DIN 980
			16	13489-864	Gummischeibe	Rubber washer	Rondelle caoutchouc		Ø 8 x 20	
			17	N 88	Sechskantschraube	Hex. screw	Vis six pans	0.016	M 8x25	DIN 933
			18	14401-620	Riemenschutz	Belt guard	Protection de courroie	2.200		
			19	14349-615	Motorwippe	Pedestal	Moto-interrupteur à bascule	1.460	U2B, U2B-H	
			20	N 89	Sechskantschraube	Hex. screw	Vis six pans	0.020	M 8x30	DIN 933
			21	N 3526	Plastikkappe	Plastic cap	Capuchon plastique		20 x 20 x 2	
			22	14446-620	Abdeckplatte	Cover plate	Plaque de recouvrement	0.300	U3E,U3E-H, U3W,U3W-	
			23	N 542	Sechskantschraube	Hex. screw	Vis six pans	0.015	M 8x16	DIN 933
			24	14680-615	Motorwippe	Pedestal	Moto-interrupteur à bascule		U3E,U3E-H,U3W,-H	
			25	64912-620	Abdeckplatte	Cover plate	Tôle de recouvrement			
			26	N 53	Sechskantschraube	Hex. screw	Vis six pans	0.005	M 6x16	DIN 933
			27	N 102	Scheibe	Washer	Rondelle	0.010	Ø 6,4	DIN 125
			28	12731-635	Füllventilbefestigung	Filling valve mounting	Fixation vanne de remplissage	0.025		
			29	N 2900	Sechskantschraube	Hex. screw	Vis six pans	0.005	M 6x25	DIN 933

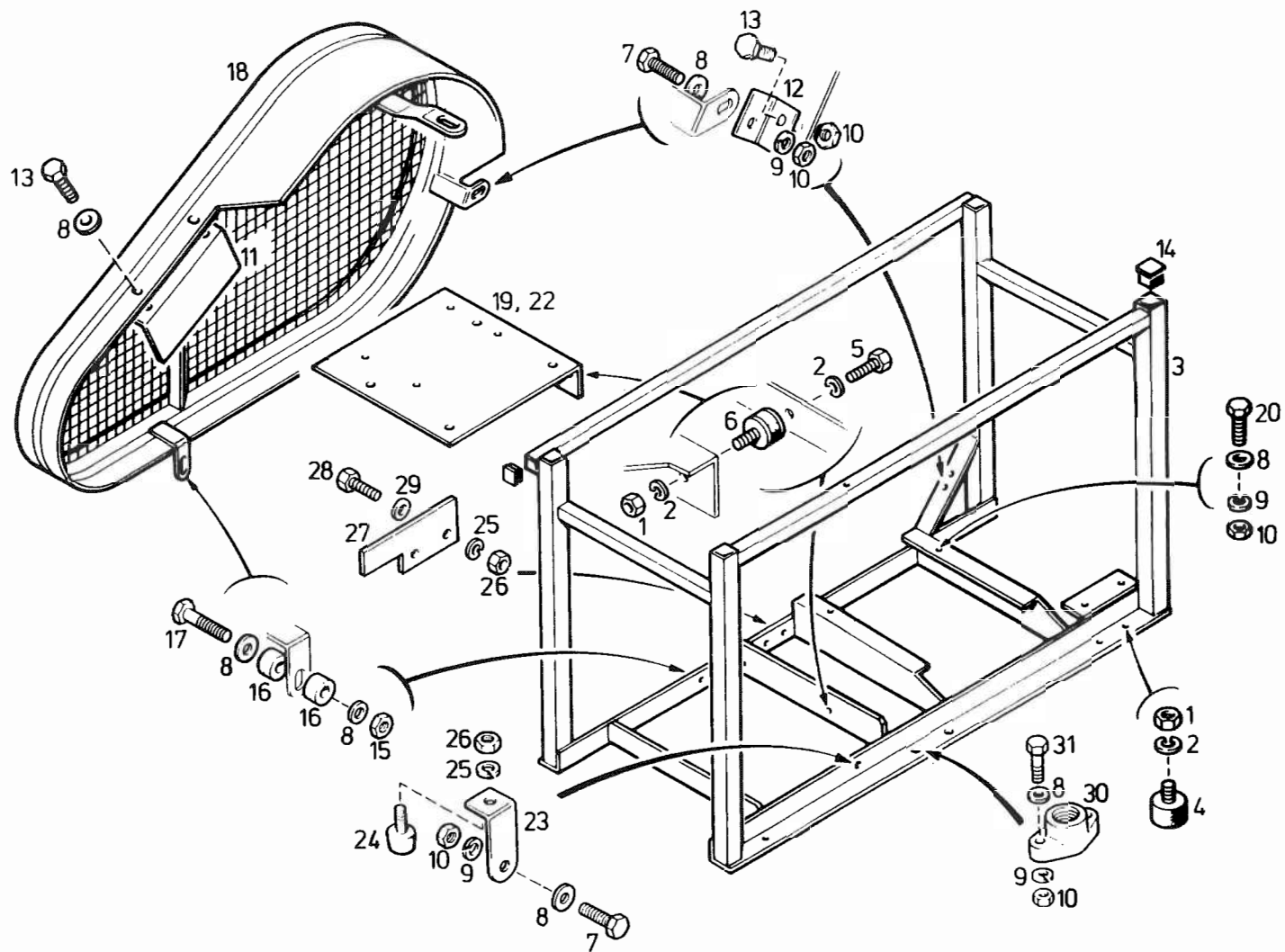



Ersatzteilsatz
Spare parts sets
Kits de pièces dét.

Bildtafel TU-12 Sturzrahmen
Figure TU-12 Protection frame
Planche TU-12 Cadre de protection

Klasse Class Classe			Pos.	Bestell-Nr Part No. No. de cde.	Benennung	Designation	Dénomination	Gewicht Weight Poids (kg)	Abmessungen Dimensions Dimensions	
0	2	5								
			1	N 177	Sechskantmutter	Hex. nut	Ecrou hex.	0.015	M 10	DIN 934
			2	N 176	Federring	Lock washer	Rondelle élastique	0.005	A 10	DIN 127
			3	14637-760	Rahmen	Frame	Cadre			
			4	N 1547	Schwingmetall	Vibration isolator	Amortisseur de vibration	0.085	Ø 50x15	
			5	N 570	Sechskantschraube	Hex. screw	Vis six pans	0.020	M 10x16	DIN 933
			6	N 1649	Schwingmetall	Vibration isolator	Amortisseur de vibration	0.125	Ø 50 x 20	
			7	N 198	Sechskantschraube	Hex. screw	Vis six pans	0.018	M 8x20	DIN 933
			8	N 58	Scheibe	Washer	Rondelle	0.005	Ø 8,4	DIN 125
			9	N 108	Federring	Lock washer	Rondelle élastique	0.005	A 8	DIN 127
			10	N 57	Sechskantmutter	Hex. nut	Ecrou hex.	0.005	M 8	DIN 934
			11	14446-620	Abdeckplatte	Cover plate	Tôle de recouvrement	0.300	U3E,U3E-H, U3W,U3W-	
			12	14721-760	Befestigungswinkel	Mounting angle	Angle de fixation	0.050	U2B, U2B-H	
			13	N 542	Sechskantschraube	Hex. screw	Vis six pans	0.015	M 6x16	DIN 933
			14	N 2757	Plastikkappe	Plastic cap	Capuchon plastique	0.007		
			15	N 370	Sechskantmutter, selbsts.	Hex. nut, self-locking	Ecrou hex., auto-freinant	0.009	NM 8	DIN 980
			16	13489-864	Gummischeibe	Rubber washer	Rondelle caoutchouc		Ø 8 x 20	
			17	N 88	Sechskantschraube	Hex. screw	Vis six pans	0.016	M 8x25	DIN 933
			18	14401-620	Riemenschutz	Belt guard	Protection de courroie	2.200		
			19	14680-615	Motorwippe	Pedestal	Moto-interrupteur à bascule		U3E,U3E-H,U3W,-H	
			20	N 89	Sechskantschraube	Hex. screw	Vis six pans	0.020	M 8x30	DIN 933
			21	N 3526	Plastikkappe	Plastic cap	Capuchon plastique		20 x 20 x 2	
			22	14349-615	Motorwippe	Pedestal	Moto-interrupteur à bascule		U3E,U3E-H,U3W,-H	
			23	14450-655	Anschlagwinkel	Stop angle	Angle de butée	0.050	U2B, U2B-H	
			24	N 1899	Anschlagpuffer	Vibration isolator	Amortisseur de vibration	0.015	U2B, U2B-H	
			25	N 100	Federring	Lock washer	Rondelle élastique	0.001	A 6	DIN 127
			26	N 287	Sechskantmutter	Hex. nut	Ecrou hex.	0.005	M 6	DIN 934
			27	64912-620	Abdeckplatte	Cover plate	Tôle de recouvrement			
			28	N 53	Sechskantschraube	Hex. screw	Vis six pans	0.005	M 6x16	DIN 933
			29	N 102	Scheibe	Washer	Rondelle	0.010	Ø 6,4	DIN 125
			30	12731-635	Füllventilbefestigung	Filling valve mounting	Fixation vanne de remplissage	0.025		
			31	N 2900	Sechskantschraube	Hex. screw	Vis six pans	0.005	M 6x25	DIN 933

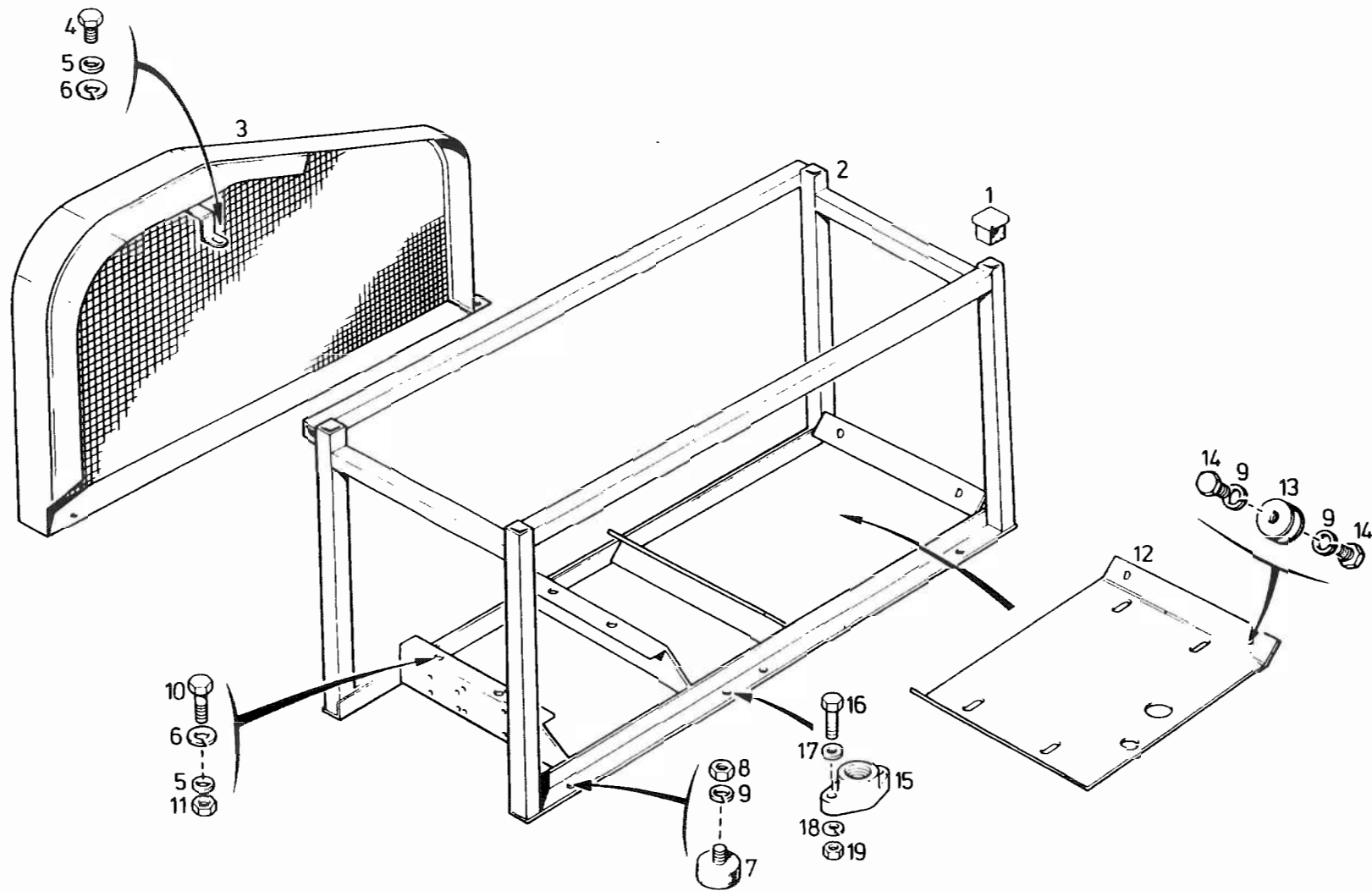

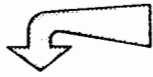

Ersatzteilsätze
Spare parts sets
Kits de pièces dét.

Bildtafel TU-13 Grundrahmen - Dieselmotor
Figure TU-13 Base frame - Diesel engine
Planche TU-13 Cadre de base - moteur Diesel

Klasse Class Classe			Pos.	Bestell-Nr Part No. No de cde.	Benennung	Designation	Dénomination	Gewicht Weight Poids (kg)	Abmessungen Dimensions Dimensions	
0	2	5								
			1	N 2757	Plastikkappe	Plastic cap	Capuchon plastique	0.007	30 x 30 x 2	
			2	55279-760	Rahmen	Frame	Cadre			
			3	55281-620	Riemenschutz	Belt guard	Protection de courroie			
			4	N 198	Sechskantschraube	Hex. screw	Vis six pans	0.018	M 8 x 20	DIN 933
			5	N 58	Scheibe	Washer	Rondelle	0.005	Ø 8,4	DIN 125
			6	N 108	Federring	Lock washer	Rondelle élastique	0.005	A 8	DIN 127
			7	N 1547	Schwingmetall	Vibration isolator	Amortisseur de vibration	0.085	Ø 50 x 15	
			8	N 177	Sechskantmutter	Hex. nut	Ecrou hex.	0.015	M 10	DIN 934
			9	N 176	Federring	Lock washer	Rondelle élastique	0.005	A 10	DIN 127
			10	N 89	Sechskantschraube	Hex. screw	Vis six pans	0.020	M 8 x 30	DIN 933
			11	N 57	Sechskantmutter	Hex. nut	Ecrou hex.	0.005	M 8	DIN 934
			12	55280-760	Motorwippe	Pedestal	Moto-interrupteur à bascule			
			13	N 3290	Schwingmetall	Vibration isolator	Amortisseur de vibration	0.140	Ø 50 x 45	
			14	N 570	Sechskantschraube	Hex. screw	Vis six pans		M 10 x 16	DIN 933
			15	12731-635	Füllventilbefestigung	Filling valve mounting	Fixation vanne de remplissage	0.025		
			16	N 2900	Sechskantschraube	Hex. screw	Vis six pans	0.005	M 6x25	DIN 933
			17	N 102	Scheibe	Washer	Rondelle	0.010	Ø 6,4	DIN 125
			18	N 100	Federring	Lock washer	Rondelle élastique	0.001	A 6	DIN 127
			19	N 287	Sechskantmutter	Hex. nut	Ecrou hex.	0.005	M 6	DIN 934

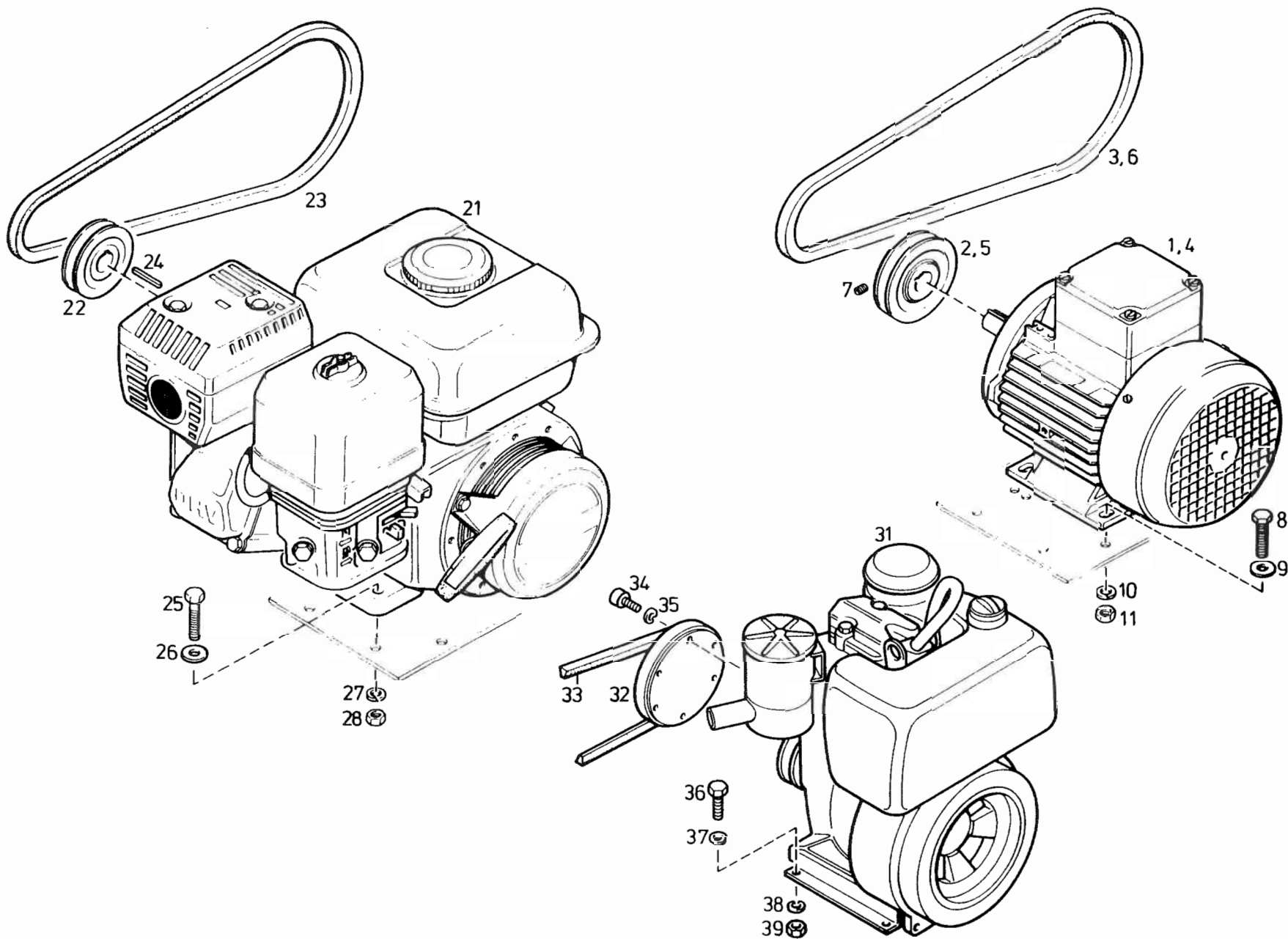



Ersatzteilsätze
Spare parts sets
Kits de pièces dét.

Bildtafel TU-14 Antriebsmotoren mit Zubehör
Figure TU-14 Drive motors with accessories
Planche TU-14 Moteurs d'entraînement avec accessoires

Klasse Class Classe			Pos.	Bestell-Nr Part No. No. de cde.	Benennung	Designation	Dénomination	Gewicht Weight Poids (kg)	Abmessungen Dimensions Dimensions
0	2	5							
			1	N 3388	Für Anlage U3E, U3E-H: Drehstrommotor	For unit U3E, U3E-H: Three-phase motor	Pour unité U3E, U3E-H: Moteur triphasé	13.50	50 Hz, 2,2 kW
			2	14386-130	Keilriemenscheibe	V-belt pulley	Poulie de courroie	2.120	Ø 170, 50 Hz
			3	N 2586	Keilriemen	V-belt	Courroie trapézoïdale	0.129	9,5x1725 La
			4	N 15750	Für Anlage U3W, U3W-H: Wechselstrommotor	For unit U3W, U3W-H: Single-phase motor	Pour unité U3W, U3W-H: Moteur à courant alternatif	19.00	50 Hz, 2,2 kW
			5	14386-130	Keilriemenscheibe	V-belt pulley	Poulie de courroie	2.120	Ø 170, 50 Hz
			6	N 3544	Keilriemen	V-belt	Courroie trapézoïdale	0.110	9,5x1662 Lw
			7	N 106	Gewindestift	Stud	Goujon	0.010	M8x12
			8	N 89	Sechskantschraube	Hex. screw	Vis six pans	0.020	M 8 x 30 DIN 933
			9	N 58	Scheibe	Washer	Rondelle	0.005	Ø 8,4 DIN 125
			10	N 108	Federring	Lock washer	Rondelle élastique	0.005	A 8 DIN 127
			11	N 57	Sechskantmutter	Hex. nut	Ecrou hex.	0.008	M 8 DIN 934
			21	N 16176	Für Anlage U2B, U2B-H: Benzinmotor	For unit U2B, U2B-H: Gasoline engine	Pour unité U2B, U2B-H: Moteur à essence		Honda, 3.7 kW
			22	14403-130	Keilriemenscheibe	V-belt pulley	Poulie de courroie	2.700	Ø 134
			23	N 3543	Keilriemen	V-belt	Courroie trapézoïdale	0.105	9,5x1675 La
			24	N 2885	Paßfeder	Key	Clavette	0.006	3/16"x3/16"x1" lg.
			25	N 64	Sechskantschraube	Hex. screw	Vis six pans	0.021	M 8 x 35 DIN 933
			26	N 58	Scheibe	Washer	Rondelle	0.005	Ø 8,4 DIN 125
			27	N 108	Federring	Lock washer	Rondelle élastique	0.005	A 8 DIN 127
			28	N 57	Sechskantmutter	Hex. nut	Ecrou hex.	0.008	M 8 DIN 934
			31	N 3807	Für Anlage U4D, U4D-H: Dieselmotor	For unit U4D, U4D-H: Diesel engine	Pour unité U4D, U4D-H: Moteur Diesel		4,5 kW
			32	56945-130	Keilriemenscheibe	V-belt pulley	Poulie de courroie		Ø 133
			33	N 2586	Keilriemen	V-belt	Courroie trapézoïdale	0.129	9,5x1725 La
			34	N 796	Innensechskantschraube	Allen screw	Vis six pans creux	0.015	M6x25 DIN 912
			35	N 100	Federring	Lock washer	Rondelle élastique	0.001	A 6 DIN 127
			36	N 3155	Sechskantschraube	Hex. screw	Vis six pans	0.015	M 10 x 25 DIN 933
			37	N 16	Scheibe	Washer	Rondelle	0.006	Ø 10,5 DIN 125
			38	N 176	Federring	Lock washer	Rondelle élastique	0.005	A 10 DIN 127
			39	N 177	Sechskantmutter	Hex. nut	Ecrou hex.	0.015	M 10 DIN 934

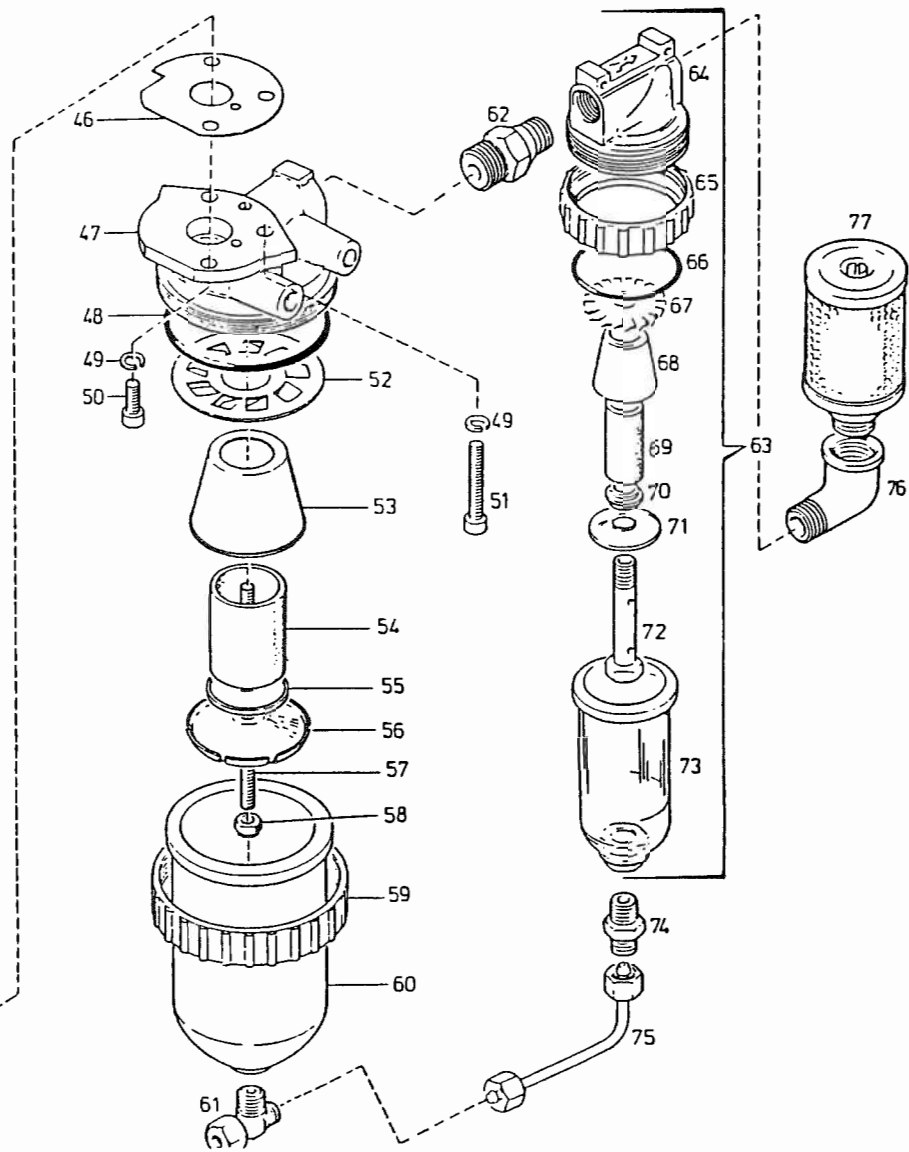
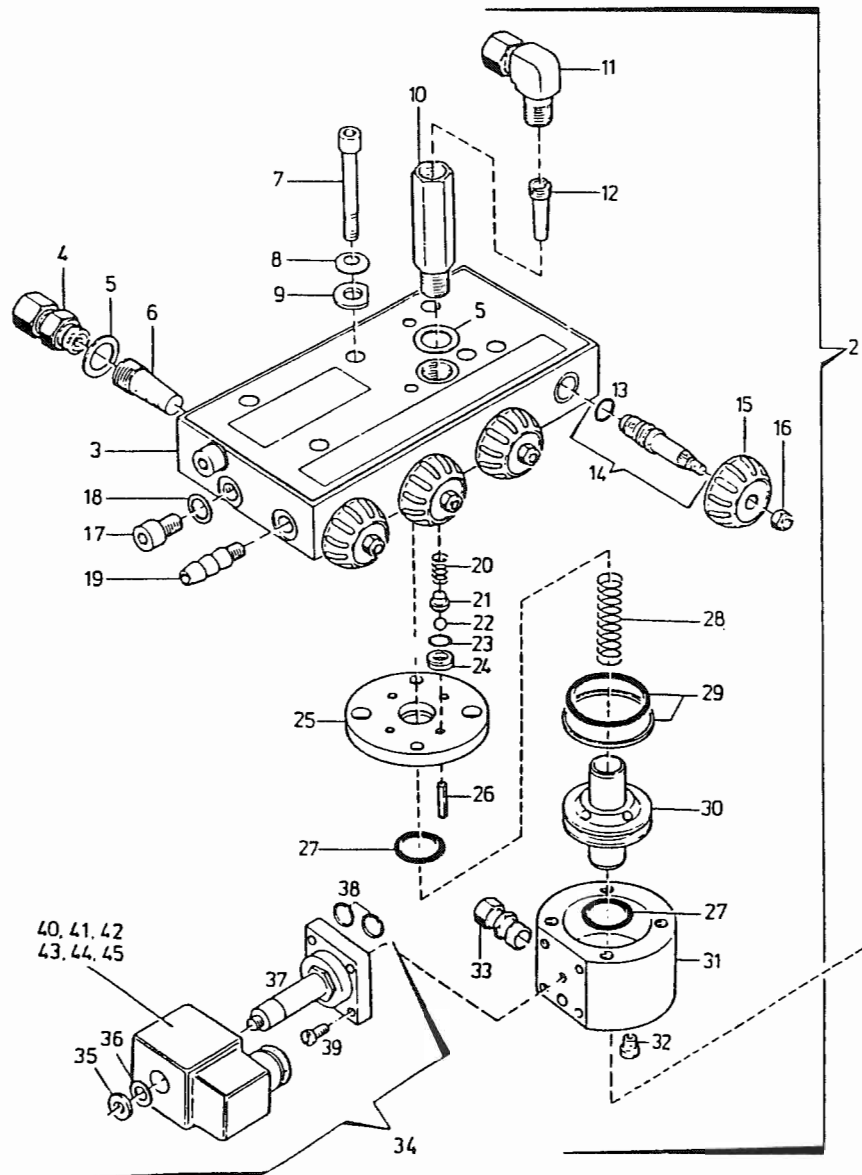



Ersatzteilsätze
Spare parts sets
Kits de pièces dét.

Bildtafel KA 1c Kondensat-Ablaufautomatik
Figure KA 1c Automatic condensate drain
Planche KA 1c Purgé automatique des condensats

Klasse Class Classe			Pos.	Bestell-Nr. Part No. No. de cde.	Benennung	Designation	Dénomination	Gewicht Weight Poids (kg)	Abmessungen Dimensions Dimensions		
0	2	5									
3	4	3	1	014226-342	Kondensatablaßeinrichtung	Condensate drain device	Purge des condensats	4,593			
			2	012717-342	Kondensatablaßventil	Drain valve	Soupape de purge du condensat	3,129			
			3	12586-342	Verteilerleiste	Distributor manifold	Corps de distributeur	1,320			
			4	N 3504	Gerade Rohrverschraubung	Male connector	Raccord droit mâle	0,050	GE 6-PSR, R 1/4"		
			5	N 1316	Dichtring	Gasket	Joint	0,002	A 13 x 20 DIN 7603		
			6	12819-635	Sinterfilter	Filter insert	Filtre en métal fritté	0,015			
			7	N 2773	Innensechskantschraube	Allen screw	Vis à six pans creux	0,015	M 6 x 50 DIN 912		
			8	N 3026	Federscheibe	Spring washer	Rondelle ressort	0,001	A 6 DIN 137		
			9	14592-342	Scheibe	Washer	Rondelle	0,005			
			10	12339-635	Anschlußstück	Connection piece	Pièce de connexion	0,102			
			11	N 1048	Winkel-Rohrverschraubung	Male elbow	Raccord en équerre mâle	0,072	WE 6-PSR, R 1/4"		
			12	N 3037	Sinterfilter	Filter insert	Filtre en métal fritté	0,005			
			13	N 3041	O-Ring	O-ring	Joint torique	0,001	Ø 6,3 x Ø 2,4		
			14	012949-342	Spindel	Spindle	Axe fileté	0,020			
			15	N 1865	Handrad	Handwheel	Manette	0,015			
			16	N 2488	Sechskantmutter, selbsts.	Hex. nut, self-locking	Ecrou hex., auto-freinant	0,002	NM 5 DIN 980		
			17	N 3830	Innensechskantschraube	Allen screw	Vis à six pans creux	0,010	M 8x10 DIN 912		
			18	N 3625	Dichtring	Gasket	Joint	0,001	A 8x14x1,5 DIN 7603		
			19	12680-342	Schlauchtülle	Hose liner	Embouchure	0,010			
			20	13369-640	Druckfeder	Coil spring	Ressort de pression	0,001			
			21	6442-342	Federführung	Spring guide	Guide de ressort	0,001			
			22	N 2799	Kugel	Ball	Bille	0,002	Ø 6 Nirosta DIN 5501		
			23	N 3331	O-Ring	O-ring	Joint torique	0,001	Ø 8,79 x Ø 1,14		
			24	13622-340	Kugelsitz	Ball seat	Siège à bille	0,001			
			25	12588-342	Führungsplatte	Guide plate	Plaque guide	0,001			
			26	12924-342	Drucksift	Pin	Goupillé de pression	0,002			
			27	N 2806	O-Ring	O-ring	Joint torique	0,001	Ø 16 x Ø 3		
			28	10529-640	Druckfeder	Coil spring	Ressort de Pression	0,008			
			29	N 2805	Gleitring mit O-Ring	Slide ring with o-ring	Anneau de guidage avec Joint torique	0,002			
						30	10511-342	Kolben	Piston	0,100	
						31	10515-342	Kondensatablaßventil-Unterteil	Drain valve, lower	0,580	
						32	N 3042	Düse	Nozzle	0,003	Ø 0,8 mm
						33	N 3890	Gerade Rohrverschraubung	Male connector	0,015	GE 6-PLR, R 1/8"
						34	057477-342	Magnetventil ohne Spule	Solenoid valve without coil	0,165	
			35		Mutter	Nut	0,007				
			36		Scheibe	Washer	0,001				
			37		Magnetventilsitz	Solenoid valve seat	0,160				
			38	N 2814	O-Ring	O-ring	0,001	Ø 16 x Ø 1,5			
			39	N 2813	Zylinderschraube	O-ring	0,005	M 4 x 12 DIN 84			
			40	N 4456	Magnetventilspule	Screw	0,005				
			41	N 4457	Magnetventilspule	Coil of solenoid valve	0,145	220 V, 50 - 60 Hz			
			42	N 4458	Magnetventilspule	Coil of solenoid valve	0,145	240 V, 50 - 60 Hz			
			43	N 4460	Magnetventilspule	Coil of solenoid valve	0,145	230 V, 50 - 60 Hz			
			44	N 16099	Magnetventilspule	Coil of solenoid valve	0,145	115 V, 50 - 60 Hz			
			45	N 16100	Magnetventilspule	Coil of solenoid valve	0,145	24 V			
							0,145	12 V			

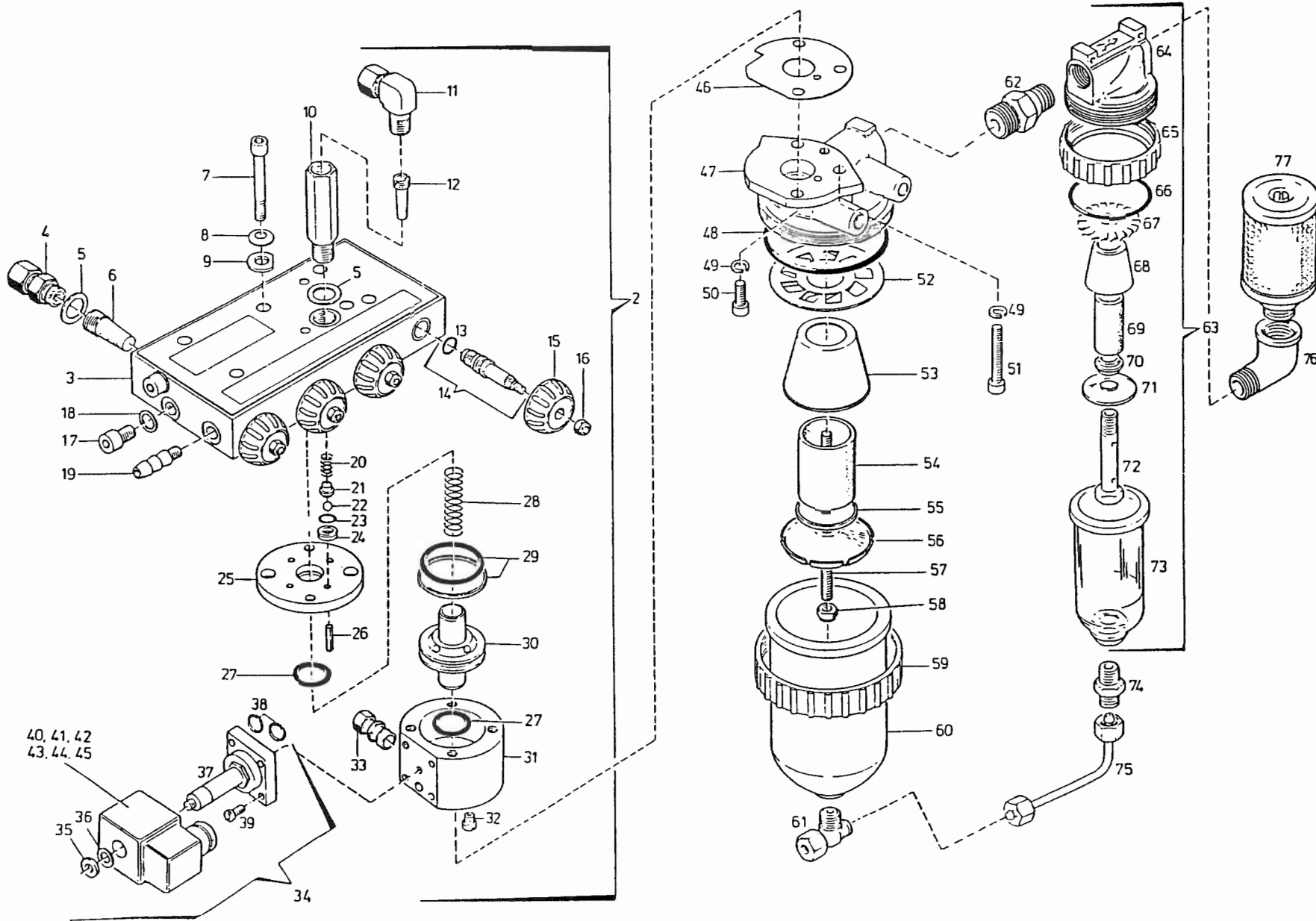



Ersatzteilsätze
Spare parts sets
Kits de pièces dét.

Bildtafel KA 1c Kondensat-Ablaufautomatik
Figure KA 1c Automatic condensate drain
Planche KA 1c Purge automatique des condensats

Klasse Class Classe			Pos.	Bestell-Nr. Part No. No. de cde.	Benennung	Designation	Dénomination	Gewicht Weight Poids (kg)	Abmessungen Dimensions Dimensions	
0	2	5								
1	1		46	14079-090	Dichtring	Gasket	Joint	0,002		
			47	14281-342	Zwischenstück	Intermediate piece	Pièce intermédiaire	0,300		
			48	N 2485	O-Ring	O-ring	Joint torique	0,002	Ø 68 x Ø 3	
			49	N 100	Federring	Lock washer	Anneau-ressort	0,001	A 6	
			50	N 158	Innensechskantschraube	Allen screw	Vis à six pans creux	0,010	M 6 x 16	
			51	N 724	Innensechskantschraube	Allen screw	Vis à six pans creux	0,015	M 6 x 40	
			52	N 2484	Verteilerblech	Vortex plate	Diffuseur	0,025		
			53	N 2483	Pralltrichter	Baffle	Entonnoir de chicane	0,006		
			54	N 2481	Filtereinsatz	Filter insert	Élément filtrant	0,065		
			55	N 2480	Teller	Disc	Cuvette	0,024		
	1			56	N 2479	Prallscheibe	Baffle washer	Disque de chicane	0,005	
				57	N 3677	Stiftschraube	Threaded pin	Goujon	0,020	M 6 x 95
				58	N 1042	Sechskantmutter, selbsts.	Hex. nut, self-locking	Ecrou hex., auto-freinant	0,002	NM 6
				59	N 3511	Überwurfmutter	Threaded collar	Bague fileté	0,100	
				60	N 3510	Mantel	Cover	Pot	0,200	
				61	N 2891	T-Rohrverschraubung	Male stud Tee	Raccord en T mâle	0,047	TE 8-LLR, R 1/8"
				62	N 3734	Doppelnippel	Nipple	Raccord	0,050	R 1/2" x R 3/8"
				63	N 3758	Abscheider	Separator	Séparateur	0,390	ND 16, R 3/8"
				64	N 2719	Filterkopf	Filter head	Tête de filtre	0,202	
				65	N 2721	Überwurfmutter	Threaded collar	Bague fileté	0,068	
	1			66	N 2720	O-Ring	O-ring	Joint torique	0,001	Ø 37 x Ø 2
				67	N 2795	Verteilerblech	Centrifugal plate	Tôle de distribution	0,005	
				68	N 2722	Pralltrichter	Baffler	Entonnoir de chicane	0,002	
				69	N 2726	Sintermetallfilter	Filter insert	Filtre en métal fritté	0,017	
				70	N 2723	Führungsscheibe	Guide plate	Plaque guide	0,003	
				71	N 2725	Prallscheibe	Baffle washer	Disque de chicane	0,002	
				72	N 2724	Nippel	Nipple	Raccord	0,027	
73				N 15491	Mantel	Cover	Pot	0,068		
74				N 7722	Gerade Rohrverschraubung	Male connector	Raccord droit mâle	0,018	GE 8-LLR, R 1/8"	
75				59293-510	Verbindungsleitung	Connection	Connexion	0,030		
1			76	N 3733	Bogen	Elbow	0,075	R 3/8" x R 1/2"		
			77	N 3512	Schalldämpfer	Silencer	Silencieux	0,060		
*				N 5053	Wartungssatz	Maintenance kit	Kit de maintenance	0,100		
				N 3577	Sinterfiltersatz	Sintered filter set	Kit de filtres en métal fritté			