

Ersatzteilliste
Spare parts catalogue
Catalogue des pièces

TO-1/2

Atemluft-Kompressoranlagen
Breathing air compressor units
Groupes compresseurs à air respirable

Oceanus

Oceanus-1
Oceanus-E
Oceanus-B



Auflage Januar 2001
Edition January 2001
Edition Janvier 2001



BAUER KOMPRESSOREN GmbH

Postfach 710260 D-81452 München / Tel. 089/78049-0 / Fax 089/78049167

e-mail: info@bauer-kompressoren.de / Internet: www.bauer-kompressoren.de

**ERSATZTEILLISTE
TO-1/2**

 ist gültig ab **Januar 2001**
 für Kompressor **Oceanus**
**PARTS LIST
TO-1/2**

 is valid as of **January 2001**
 for compressor model **Oceanus**
**CATALOGUE DES PIECES
TO-1/2**

 est valable à partir d'**Janvier 2001**
 pour les compresseurs de type
Oceanus

Baugruppe	Assembly	Groupe d'assemblage	Bildtafel/ Figure/ Planche
Kurbelgehäuse, Triebwerk, Ventilator- rad, Ölpumpe	Crankcase, driving gear, fan- wheel, oil pump	Carter de vilebrequin, embiellage, ventilateur, pompe d'huile	TO-1
Kolben, Zylinder	Pistons, cylinders	Pistons, cylindres	TO-2
Ventilköpfe, Ventile	Valve heads, calves	Culasses, clapets	TO-3
Kühler	Cooler	Refroidisseur	TO-4
Ansaugfilter, Zwischenfilter	Intake filter, intermediate separator	Filtre d'aspiration, séparateur intermédiaire	TO-5
Filtersystem P21	Filter system P21	Système de filtration P21	TO-6
Druckhalteventil, Fülleinrichtung	Pressure maintaining valve filling device,	Soupape de maintien de pression dispositif de remplissage,	TO-7
Umschalteneinrichtung PN 200/PN 300	Change-over device	Dispositif sélecteur PN 200/PN 300 ...	TO-8
Rahmen mit Zubehör	Frame with accessories	Cadre avec accessoires	TO-9
Antriebsmotoren mit Zubehör	Driving motors with accessories	Moteurs d'entraînement avec accessoires	TO-10

Wichtige Hinweise für Teilebestellung:

Bestell-Nr., die mit der Ziffer 0 beginnen, bezeichnen Baugruppen, die komplett geliefert werden. Teile ohne Bestell-Nr. sind nur zur Information für die Montage aufgeführt. Sie sind nicht als Ersatzteil erhältlich. Bei Ersatzteilbestellungen erwarten Sie unsere richtige Lieferung; deshalb benötigen wir von Ihnen folgende Angaben (siehe unten gezeigtes Typenschild):

1. Modellbezeichnung, Fabrik-Nr. sowie Fertigungsstand von Anlage/Block
2. Stückzahlen
3. Benennung und Best.-Nr. des gewünschten Teils

Bestell-Beispiel:

Für Kompressoranlage ...
Fabrik-Nr. 524-0528/1/2 drei Dichtungen
8263-090

Important notes for spare parts orders:

Part nos. beginning with digit 0 indicate parts available as complete assemblies. Parts without part no. are indicated for assembly reference, only. These parts are not available as single parts. When placing an order for spare parts, please give the following items so as to ensure our correct delivery (see identification plate shown below):

1. Model, serial no. as well as design standard of unit/block
2. Quantity required
3. Name and part no.

Example for order:

For compressor unit ...
serial no. 524-0528/1/2, three gaskets
8263-090

Avis important pour la commande de pièces:

Les nos. de commande commençant par le chiffre 0 indiquent les pièces livrées au complet. Les pièces sans no. de commande sont indiquées uniquement pour information de montage. Elles ne sont pas livrées individuellement. Pour que la livraison de pièces de rechange corresponde à la commande, veuillez bien nous fournir les données suivantes (voir plaque d'identité ci-dessous):

1. Modèle, no. de série et standard de construction de bloc compresseur/groupe
2. Quantité désirée
3. Dénomination et no. de commande de la pièce désirée

Exemple de commande:

Pour groupe compresseur ...
no. de série 524-0528/1/2, trois joints no. de cde. 8263-090



Wartungssätze

- a = Wartungssatz 500 h bzw. bei Bedarf
- b = Wartungssatz 1000 h, mind. jährlich
- c = Wartungssatz 2000 h, mind. alle 2 Jahre

In den Spalten sind die im entsprechenden Satz enthaltenen Teile angekreuzt. Bitte beachten, daß die höheren Sätze die untergeordneten nicht beinhalten, d.h. für eine 2000-Stunden-Wartung wird 1x Satz a, 1x Satz b und 1x Satz c benötigt.



Maintenance kit

- a = Maintenance kit 500 h or as required
- b = Maintenance kit 1000 h, at least annually
- c = Maintenance kit 2000 h, at least bi-annually

The columns contain the parts that are included in the respective parts set. Please note that the higher graded kits do not include the lower ones, i.e. for a 2000 hours maintenance, one kit a, one kit b plus one kit c are required.



Kits de maintenance :

- a = Kit d'entretien 500 h ou au besoin
- b = Kit d'entretien 1000 h, au moins une fois par an
- c = Kit d'entretien 2000 h, au moins tous les 2 ans

Les pièces contenues dans les kits correspondants sont marquées d'une croix dans les colonnes. Veuillez observer que les kits supérieurs ne contiennent pas les kits subordonnés, c'est-à-dire pour un entretien de 2000 heures il faut avoir 1x kit a, 1x kit b et 1x kit c.

**Anmerkungen zur Identifikation:
Remarks for identification:
Remarques pour l'identification:**

Modell/Model/Modèle		Fabrik-Nr./Serial no./Numéro de série	
<input type="checkbox"/>		<input type="checkbox"/>	
Volumenstrom m ³ /min	<input type="checkbox"/>	Jahr / Year	<input type="checkbox"/>
Free air delivery Scfm	<input type="checkbox"/>	n/min. / r.p.m.	<input type="checkbox"/>
Betriebsüberdruck bar	<input type="checkbox"/>	kW	<input type="checkbox"/>
Max. working press. psig	<input type="checkbox"/>	CE	
		KB 73708	
		Fertigungsstand / Modification no. / No. de modification	
		Anlage/Unit/Groupe	
		Kompressorblock / Compressor block / Bloc compresseur	



ACHTUNG

Nur Schrauben und Stiftschrauben der Qualität 8.8 verwenden!



ATTENTION

Use only screws and studs in quality 8.8! This quality is equivalent to SAE J 429 grade 5.



ATTENTION

N'utiliser que des vis et des goujons filetés de la qualité 8.8!

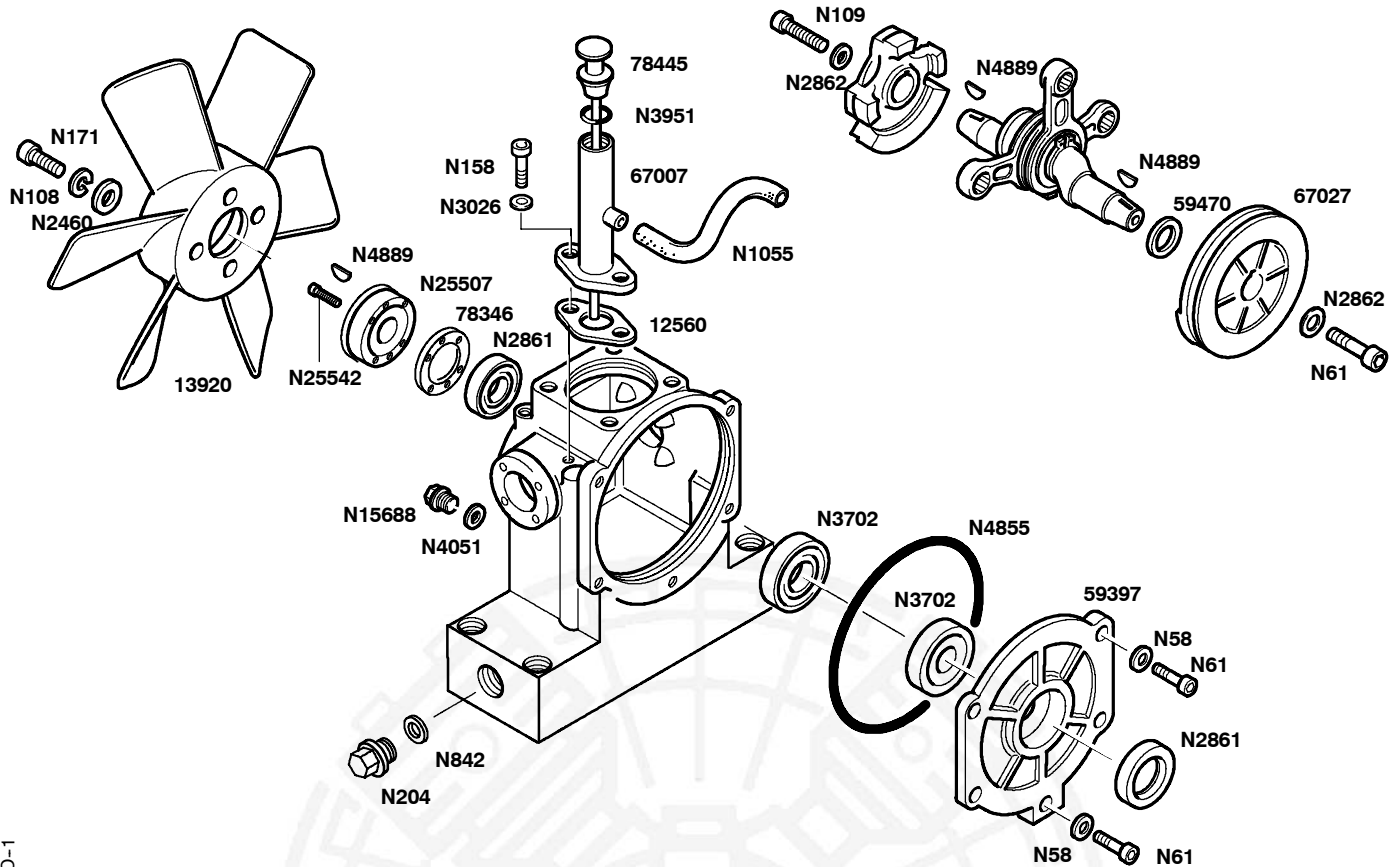

TO-1

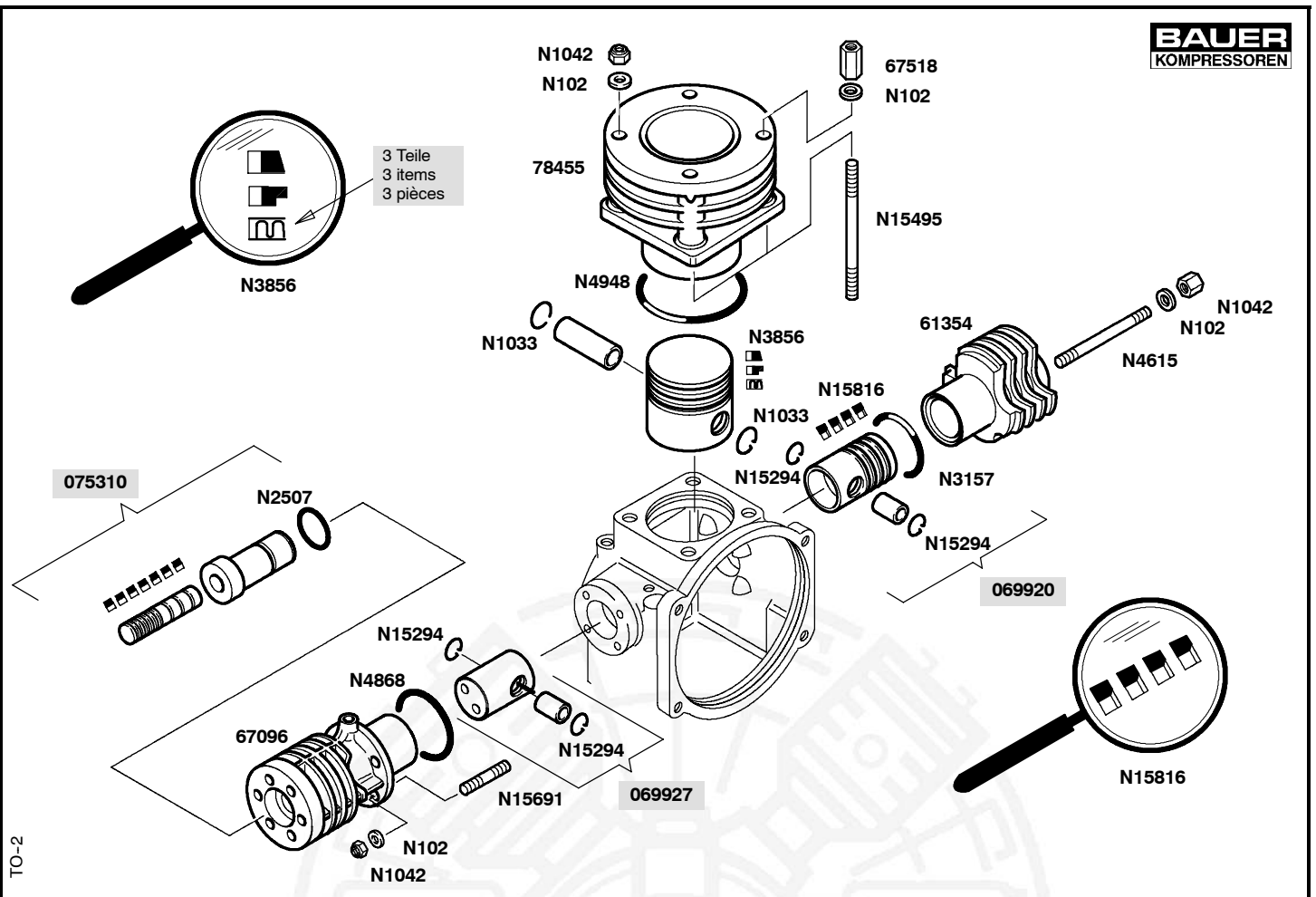

Wartungssätze
Maintenance sets
Kits d'entretien
Bildtafel TO-1 **Kurbelgehäuse, Triebwerk, Ventilatorrad**
Figure TO-1 **Crankcase , driving gear, fanwheel**
Planche TO-1 **Carter de vilebrequin, embiellage, ventilateur**

Klasse/ Class/ Classe			Bestell-Nr. Part No. No. de cde.	Benennung	Designation	Dénomination	Gewicht Weight Poids (kg)	Abmessungen Dimensions Dimensions	
a	b	c							
			12560	Dichtung	Gasket	Joint	0.001		
			13920	Ventilatorrad	Fan	Ventilateur	0.160		
			59397	Lagerdeckel	Cover	Chapeau de palier	0.370		
			59470	Anlaufscheibe	Thrust washer	Rondelle d'appui	0.003		
			67007	Öleinfüllstutzen	Oil filler	Tubulure de rempliss. d'huile	0.120		
			67027	Keilriemenscheibe	V-belt pulley	Poulie à gorge	1.780		
			78346	Dichtung	Gasket	Joint	0.001		
			78445	Olpeilstab	Dip-stick	Jauge d'huile	0.022		
			N58	Scheibe	Washer	Rondelle	0.002	B 8,4	DIN125
			N61	Innensechskantschr.	Allen screw	Vis à six pans creux	0.012	M 8 x 25	DIN912
			N108	Federring	Spring washer	Rondelle élastique	0.002	A 8	DIN127
			N109	Innensechskantschr.	Allen screw	Vis à six pans creux	0.014	M 8 x 30	DIN912
			N158	Innensechskantschr.	Allen screw	Vis à six pans creux	0.005	M 6 x 16	DIN912
			N171	Innensechskantschr.	Allen screw	Vis à six pans creux	0.012	M 8 x 20	DIN912
			N204	Verschlusschraube	Plug with plastic gasket	Bouchon fileté	0.030	G 3/8A;St;A3A	DIN910
			N842	Dichtung	Gasket	Joint		A 17 x 24 x 2	DIN7603
			N1055	Schlauch	Hose	Tuyau		DN5; PVC; 110 mm	
			N2460	Scheibe	Washer	Rondelle	0.002	A 8,4	DIN9021
			N2861	Wellendichtring	Shaft seal	Bague d'étanchéité	0.017	A 20 x Ø 47 x 7	
			N2862	Scheibe	Washer	Rondelle	0.002	Ø 8,4	DIN7349
			N3026	Federring	Spring washer	Rondelle élastique		A 6	
			N3702	Zylinderrollenlager	Roller bearing	Roulement à rouleaux cyl.	0.148	Ø 20 x Ø 52 x 15	
			N3951	O-Ring	O-ring	Joint torique	0.001	Ø 12 x 2,5	
			N4051	Dichtung	Gasket	Joint	0.001	A 10 x 15	DIN7603
			N4855	O-Ring	O-ring	Joint torique	0.002	Ø 140 x 2	
			N4889	Scheibenfeder	Key	Clavette disque	0.002	3 x 5	DIN6888
			N15688	Verschlusschraube	Plug	Bouchon fileté	0.011	R 1/8"	DIN908
			N25542	Sechskantschraube	Hex. screw	Vis hex.		M4x35	DIN24014
			N25507	Ölpumpe	Oil pump	Pompe d'huile			

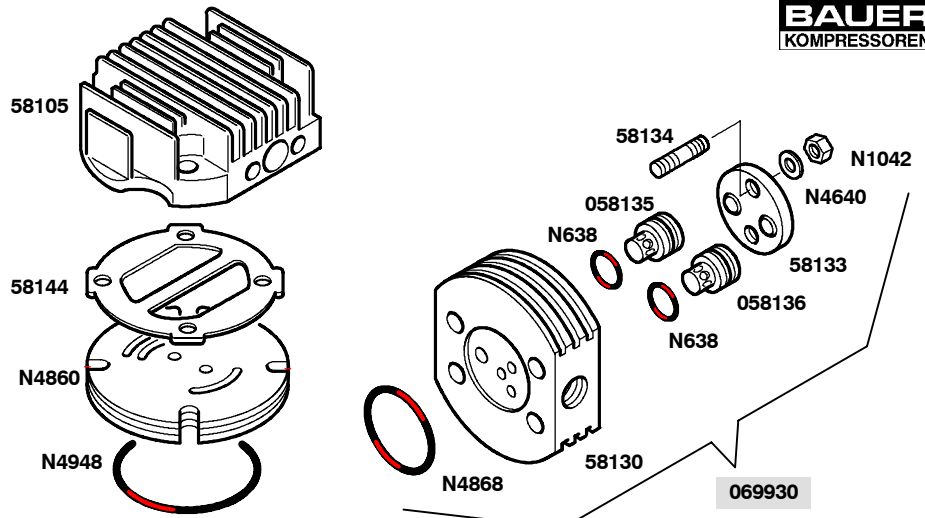

Wartungssätze Maintenance sets Kits d'entretien	Bildtafel	TO-2	Kolben und Zylinder
	Figure	TO-2	Pistons and cylindres
	Planche	TO-2	Pistons et cylindres

Klasse/ Class/ Classe			Bestell-Nr. Part No.	Benennung	Designation	Dénomination	Gewicht Weight Poids (kg)	Abmessungen Dimensions Dimensions
a	b	c	No. de cde.					
			069920	Kolben 2. Stufe kpl.	Piston 2nd stage assy.	Piston 2e étage		
			069927	Kolben 3. Stufe kpl.	Piston 3rd stage assy.	Piston 3e étage		
	X		075310	Kolbenbüchse kpl.	Piston and sleeve assy.	Douille et piston cpl.	0.180	
			61354	Zylinder 2. Stufe	Cylinder 2nd stage	Cylindre 2e étage	0.340	
			67096	Zylinder	Cylinder	Cylindre	0.210	
			67518	Sechskantmutter	Hex nut	Ecrou hex.		m6; SW13
			78455	Zylinder 1. Stufe	Cylinder 1st stage	Cylindre 1er étage	0.865	Ø70; 24Hub;GGL-25Cr
			N102	Scheibe	Washer	Rondelle	0.005	Ø 6,4 DIN125
			N1033	Sicherungsring	Circlip	Circlip	0.001	
X			N1042	Sechsk.-mutter, selbsts.	Hex. nut, self-locking	Ecrou hex., auto-freinant	0.002	NM 6 DIN980
			N2507	O-Ring	O-ring	Joint torique	0.001	Ø 18,77 x 1,78
	X		N3157	O-Ring	O-ring	Joint torique	0.001	Ø 31,47 x 1,78
			N3856	Kolbenringsatz	Piston ring set	Jeu de segments de piston	0.024	Ø 70
			N4615	Stiftschraube	Stud	Goujon fileté		M 6 x 70 DIN835
	X		N4868	O-Ring	O-ring	Joint torique	0.001	Ø 33,05 x 1,78
	X		N4948	O-Ring	O-ring	Joint torique	0.001	Ø 72,75 x 1,78
			N15294	Sicherungsring	Circlip	Circlip	0.001	
			N15495	Stiftschraube	Stud	Goujon fileté	0.006	M 6 x 90 DIN835
			N15691	Stiftschraube	Stud	Goujon fileté	0.006	M 6 x 20 DIN835
			N15816	Kolbenringsatz	Piston ring set	Jeu de segments de piston	0.008	Ø 28



TO-3

Wartungssätze
Maintenance sets
Kits d'entretien
Bildtafel TO-3 Ventilköpfe, Ventile
Figure TO-3 Valve heads, valves
Planche TO-3 Culasses, clapets

Klasse/ Class/ Classe			Bestell-Nr. Part No. No. de cde.	Benennung	Designation	Dénomination	Gewicht Weight Poids (kg)	Abmessungen Dimensions Dimensions	
a	b	c							
	X		07790	Saugventil	Intake valve	Clapet d'aspiration	0.007		
	X		014121	Druckventil	Discharge valve	Clapet de refoulement	0.020		
	X		058135	Druckventil kpl.	Discharge valve assy.	Clapet de refoulement cpl.	0.020		
	X		058136	Saugventil kpl.	Inlet valve assy.	Clapet d'aspiration cpl.	0.007		
			069930	Ventilkopf, 2. Stufe kpl.	Valve head assy. 2nd st.	Culasse cpl. de 2e étage	0.595		
			069931	Ventilkopf 3. Stufe kpl.	Valve head assy. 3rd st.	Culasse cpl. de 3e étage	0.595		
			58105	Ventilkopf 1. Stufe	Valve head 1st stage	Culasse de 1er étage	0.395		
			58130	Ventilkopf	Valve head	Culasse	0.320		
			58133	Druckflansch	Tension flange	Bride de friction	0.063		
			58134	Gewindestift	Stud	Goujon fileté	0.010		
			58144	Dichtung	Gasket	Joint	0.017		
			59449	Verschraubung	Plug	Bouchon fileté	0.035		
			59457	Ventilkopfdeckel	Valve head cover	Couvercle de culasse	0.085		
			61362	Ventilkopf 3. Stufe	Valve head 3rd stage	Culasse de 3e étage	0.370		
			N102	Scheibe	Washer	Rondelle	0.005	Ø 6,4	DIN125
			N638	O-Ring	O-ring	Joint torique	0.001	Ø 11 x 2,5	
X			N1042	Sechskantmutter, selbsts.	Hex. nut, self locking	Ecrou hex., auto-freinant	0.002	NM 6	DIN980
			N1776	Innensechskantschraube	Allen screw	Vis à six pans creux	0.035	M 6 x 55	DIN912
			N2789	O-Ring	O-ring	Joint torique	0.005	Ø15,6x1,78;FPM;90Sh.	
			N4640	Spannscheibe	Tension washer	Rondelle de friction	0.007	A 6	DIN6796
	X		N4860	Lamellenventil	Reed valve	Clapet à lamelles	0.372		
X			N4868	O-Ring	O-ring	Joint torique	0.003	Ø 33,05 x 1,78	
			N4948	O-Ring	O-ring	Joint torique	0.009	Ø72,75x1,78;NBR;70Sh.	

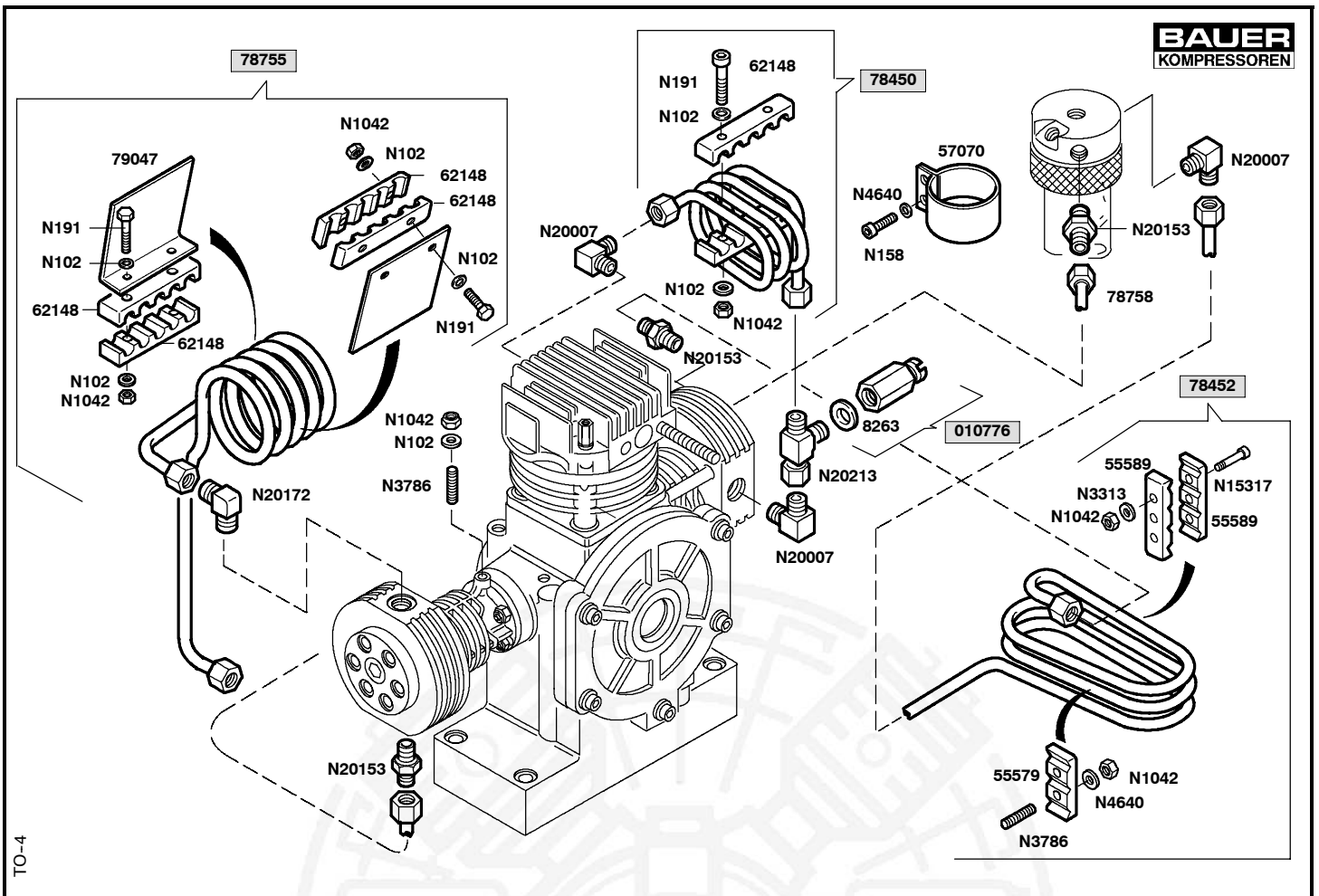

Wartungssätze
Maintenance sets
Kits d'entretien

Bildtafel TO-4 Kühler
Figure TO-4 Cooler
Planche TO-4 Refroidisseur

Klasse/ Class/ Classe			Bestell-Nr. Part No.	Benennung	Designation	Dénomination	Gewicht Weight Poids (kg)	Abmessungen Dimensions Dimensions	
a	b	c	No. de cde.						
			010776	Sicherheitsventil, 1. Stufe	Safety valve, 1st stage	Soupape der sûreté, 1er ét.	0.060	PN8 bar	
			8263	Dichtung	Gasket	Joint	0.002		
			55579	Fixierstück	Bracket	Fixation	0.020		
			55589	Fixierstück	Bracket	Fixation	0.025		
			57070	Rohrschelle	Clamp	Bride			
			62148	Rohrklemme	Bracket	Fixation	0.015		
			78450	Zwischenkühler 1./2. St.	Inter-cooler 1st/2nd st.	Refroid. intermed. 1er/2e ét.	0.135		
			78452	Zwischenkühler 2. Stufe	Inter-cooler 2nd stage	Refroid. intermed. 2e étage	0.220		
			78755	Nachkühler kpl.	After-cooler assy.	Refroidisseur final cpl.	0.360		
			78758	Rohrleitung	Tube assy.	Tuyau cpl.			
			79047	Luftleitblech	Baffle	Conduite d'air			
			N102	Scheibe	Washer	Rondelle	0.005	Ø 6,4	DIN125
			N158	Innensechskantschraube	Allen screw	Vis à six pans creux	0.005	M6x16	DIN 912
			N191	Sechskantschraube	Hex. screw	Vis hexagonale	0.008	M 6 x 30	DIN933
			N1042	Sechskantmutter, selbsts	Hex. nut, self locking	Ecrou hex., auto-freinant	0.002	NM 6	DIN980
			N3313	Scheibe	Washer	Rondelle	0.002	A 6,4	DIN9021
			N3786	Stiftschraube	Stud	Goujon fileté		M 6 x 30	DIN835
			N4640	Scheibe	Washer	Rondelle	0.002	6; Fst; A3A	DIN 6796
			N15317	Innensechskantschraube	Allen screw	Vis à six pans creux		M 6 x 35	DIN7991
			N20007	Winkelverschraubung	Male elbow	Raccord coudé mâle	0.057	WES 10 - LRK	
			N20153	Gerade Rohverschraubg.	Male connector	Raccord droit mâle		GES10 LRK; G1/4";St.	
			N20172	Winkelverschraubung	Male elbow	Raccord coudé mâle	0.057	WES 8 - SRK	
			N20213	Einstellbare L-Versch.	Adjustable male run Tee	Raccord en T renversé or.	0.058	ELS - 10 L-SV	

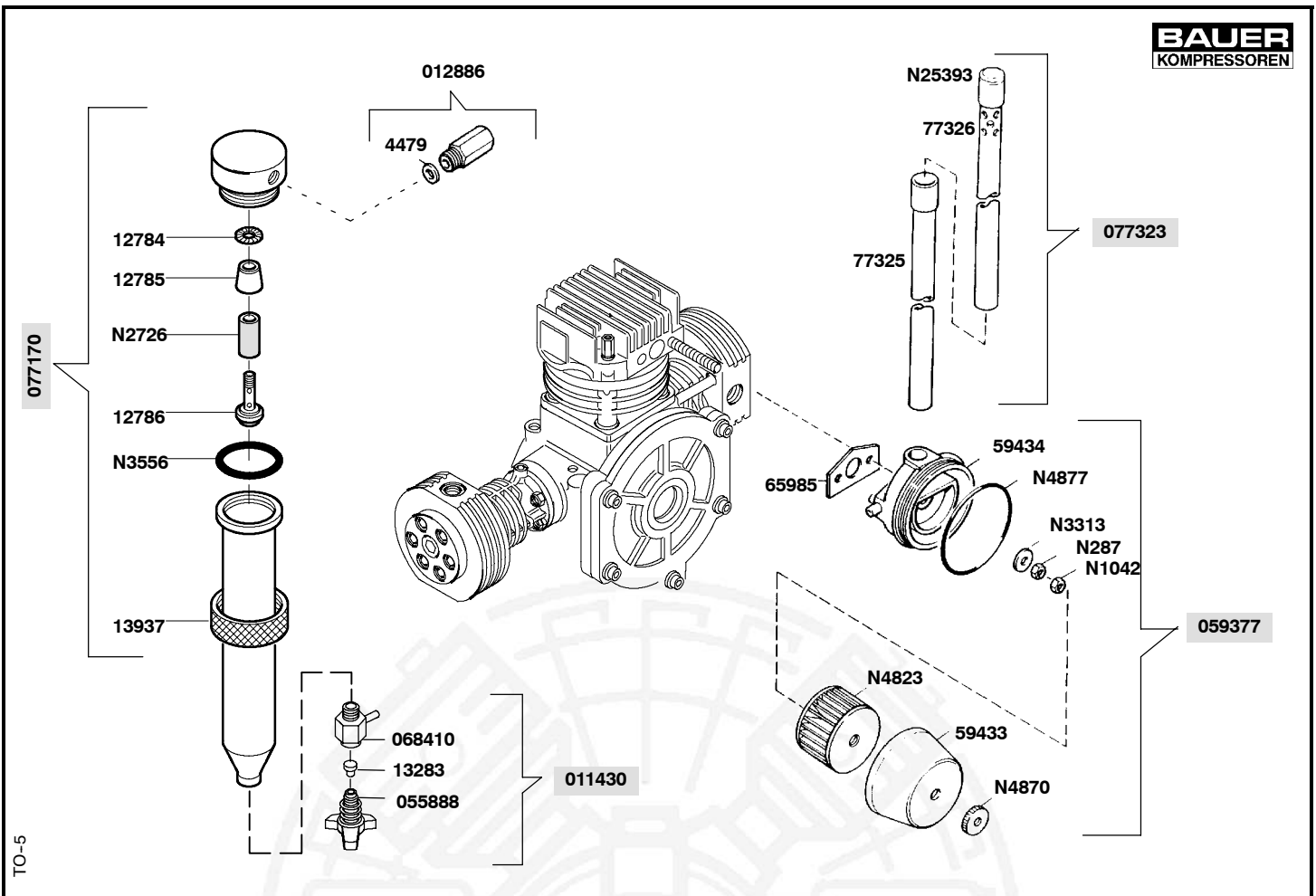

Wartungssätze
Maintenance sets
Kits d'entretien

Bildtafel TO-5 Ansaugfilter, Zwischenfilter
Figure TO-5 Intake filter , intermediate separator
Planche TO-5 Filtre d'aspiration, séparateur intermédiaire

Klasse/ Class/ Classe			Bestell-Nr. Part No. No. de cde.	Benennung	Designation	Dénomination	Gewicht Weight Poids (kg)	Abmessungen Dimensions Dimensions	
a	b	c							
			011430	Kondensatablaßhahn kpl	Condensate drain tap	Robinet de purge de cond.			
			012886	Sicherheitsventil, 2. St.	Safety valve, 2nd stage	Soupape de sûreté, 2e étage	0.055	PN80	
			055888	Knebelschraube kpl.	Tommy screw assy.	Vis a garret avec ressort			
			059377	Ansaugfilter kpl.	Intake filter assy.	Filtre d'aspiration cpl.	0.182	nur/only/seulem. O2B	
			068410	Ablaßhahnkörper, kpl.	Drain valve body	Corps de robinet de purge			
			077170	Zwischenfilter kpl.	Intermediate separator	Séparateur intermédiaire cpl.	0.700		
			077323	Ansaugteleskop	Telescopic intake tube	Télescope d'aspiration	0.253		
			12784	Verteilerblech	Distribution plate	Toile de distribution			
			12785	Prallrichter	Cône de dispersion	Entonnoir de chicane			
			12786	Mittelschraube	Center screw	Vis centrale			
X			13283	Dichtung	Gasket	Joint			
			13937	Überwurfmutter	Threaded collar	Ecrou	0.125		
			59433	Filterkappe	Filter cap	Chapeau de filtre	0.020		
			59434	Ansaugfilteraufnahme	Filter support	Support de filtre	0.065		
			64498	Dichtung	Gasket	Joint	0.002		
			65985	Dichtung	Gasket	Joint			
			77325	Ansaugteleskoprohr	Telescopic intake tube	Télescope d'aspiration			
			77326	Ansaugteleskoprohr	Telescopic intake tube	Télescope d'aspiration			
			N287	Sechskantmutter	Hex. nut	Ecrou hex.	0.005	M 6	DIN934
			N1042	Sechskantmutter,selbsts	Lock nut	Ecrou hex., auto-freinant	0.005	NM 6	DIN980
X			N2726	Filtereinsatz	Filter insert	Element filtrant		17x13x30	
			N3313	Scheibe	Washer	Rondelle	0.005	A 6.4	DIN9021
X			N3556	O-Ring	O-ring	Joint torique	0.001	Ø 45 x 2	
X			N4823	Filterpatrone	Filter cartridge	Cartouche filtrante	0.037		
			N4870	Rändelmutter	Knurled nut	Ecrou moleté	0.017	M 6	DIN467
X			N4877	O-Ring	O-ring	Joint torique	0.001	Ø 76 x 2	
			N25393	Blindstopfen	Plug	Bouchon			

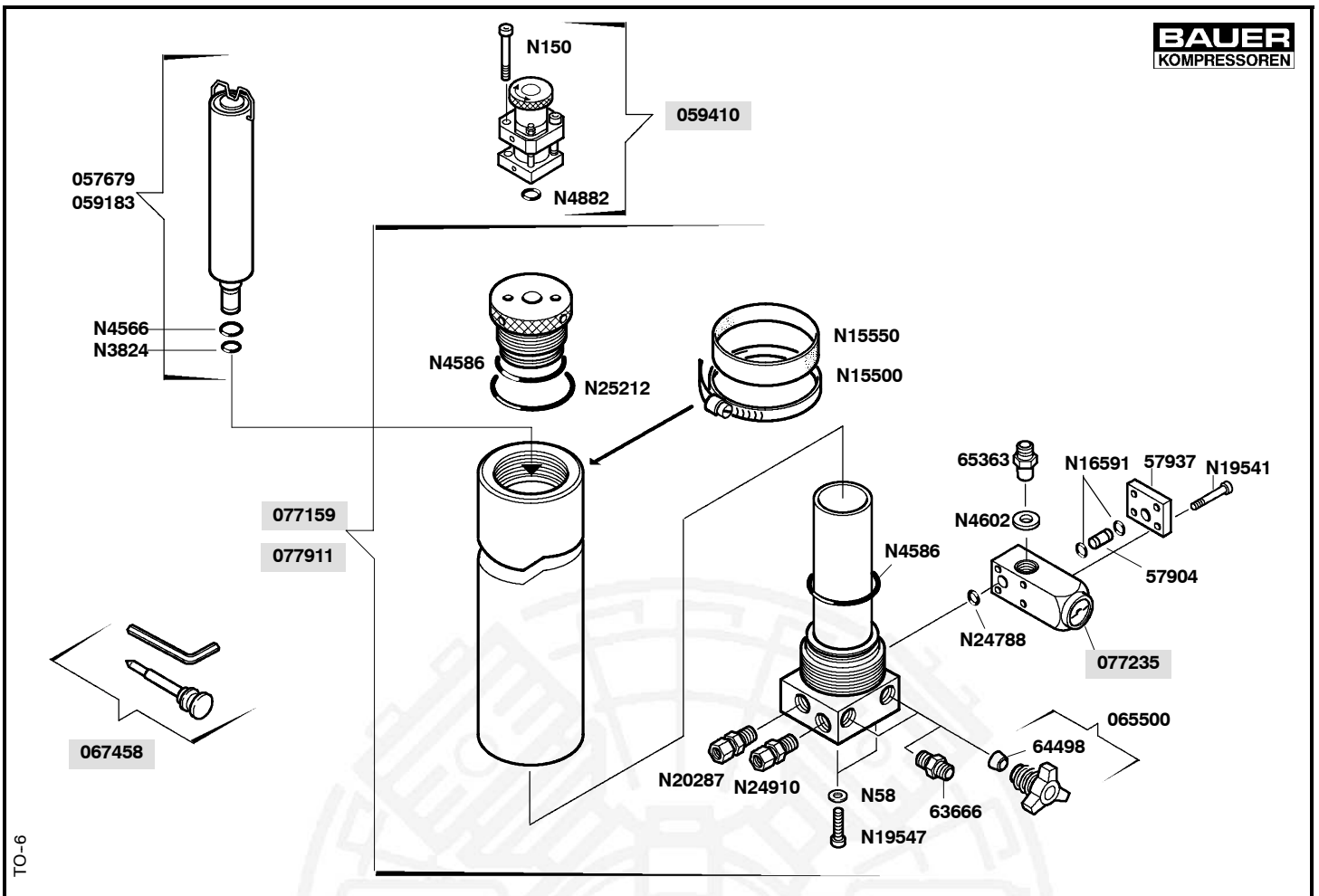

Wartungssätze Maintenance sets Kits d'entretien	Bildtafel	TO-6	Filtersystem P21
	Figure	TO-6	Filter system P21
	Planche	TO-6	Système de filtration P21

Klasse/ Class/ Classe			Bestell-Nr. Part No. No. de cde.	Benennung	Designation	Dénomination	Gewicht Weight Poids (kg)	Abmessungen Dimensions Dimensions
a	b	c						
			057679	Triplexpatrone	Triplex cartridge	Cartouche Triplex	0.300	MS-AC-MS
			059183	Triplexpatrone mit CO-E.	Triplex cart. with CO rem	Cart. Triplex avec éli. CO	0.300	AC-MS-MS-HP
			**059410	Sicherheitsventil	Safety valve	Soupape de sûreté	0.500	100 - 350 bar
			065500	Kondensatablaßhahn kpl	Condensate drain tap	Robinet de purge cpl.	0.090	
			067458	Werkzeugsatz f. Knebels	Tool set for petcock hand	Jeu d'out. pour rob. de pur		Zubehör/accessory
			077159***	Filter P21 (ohne Patrone)	Filter P21 (without cartr.)	Syst. P21 (sans cartouche)		Austria,Germany,France
			077235	Druckhalteventil	Pressure maintaining v.	Clapet de maintien de pr.	0.240	
			077911***	Filter P21 (ohne Patrone)	Filter P21 (without cartr.)	Syst. P21 (sans cartouche)		nur Japan/Japan only
			57904	Verbindungsrohr	Connection pipe	Conduite de connexion		
			57937	Abschlußdeckel	Cover	Couvercle de recouvrement	0.048	
			61452	Drehstift f. Patronenwech	Pin for cartridge change	Broche		nicht abgeb./not shown
			63666	Gerade Rohrverschr.	Male connector	Raccord droit mâle		
			64498	Dichtung	Gasket	Joint	0.002	
			65363	UNIMAM-Verschraub.	Connection	Raccord		
			N58	Scheibe	Washer	Rondelle	0.005	B 8.4 DIN 125
			N150	Innensechskantschraube	Allen screw	Vis à six pans creux		M8x60, DIN 912
			N3824	O-Ring	O-ring	Joint torique	0.004	Ø 7,59 x 2,62
			N4566	O-Ring	O-ring	Joint torique	0.001	Ø 9,19 x 2,62
X			N4586	O-Ring	O-ring	Joint torique	0.004	Ø 59,92 x 3,53
	X		N4602	USIT-Ring	USIT-Ring	Joint	0.001	U 14-18.7-1.5
			N4882	O-Ring	O ring	Joint torique		16x2
			N15500	Gummiprofil	Rubber	Profilé en caoutschouc		12 mm; 260 mm
			N15550	Schlauchschelle	Clamp	Collier		T1; 80 - 100; St
	X		N16591	O-Ring	O-ring	Joint torique	0.005	Ø 5 x 1,5; FPM; 90 Sh.
			N19541	Innensechskantschraube	Allen screw	Vis à six pans creux	0.015	M 6 x 60 DIN912
			N19547	Innensechskantschraube	Allen screw	Vis à six pans creux	0.015	M 8 x 20 DIN912
			N20287	Gerade Rohrverschraub.	Male connector	Raccord droit mâle	0.055	GES 8 SR - WD
X			N24788	O-Ring	O-ring	Joint torique	0.006	Ø 11 x 1,5; NBR; 70 Sh.

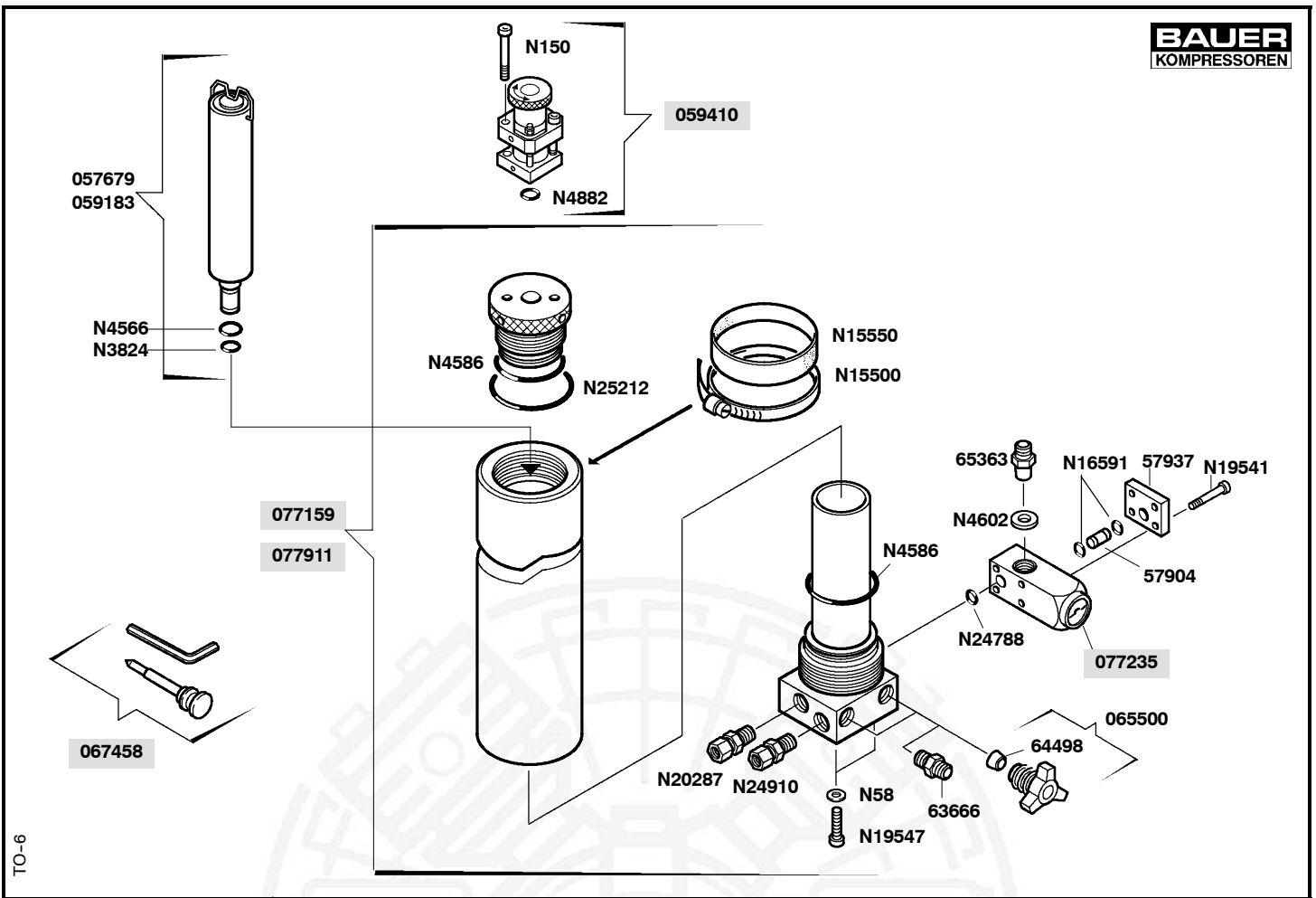

Wartungssätze
Maintenance sets
Kits d'entretien

Bildtafel TO-6 Filtersystem P21
Figure TO-6 Filter system P21
Planche TO-6 Système de filtration P21

Klasse/ Class/ Classe			Bestell-Nr. Part No.	Benennung	Designation	Dénomination	Gewicht Weight Poids (kg)	Abmessungen Dimensions Dimensions
a	b	c	No. de cde.					
			N24910	L-Schnellverschraubung	Male run T connector	Raccord en T renversé		
X			N25212	O-Ring	O-ring	Joint torique	0.008	Ø 63,17 x 2,62 90Sh.
			*	nur zusammen lieferbar	available only as a set	ne sont livrées qu'ensemble		
			**	Druck bei Bestellung angeben	Indicate pressure on order	Indiquer la pression à la commande		
			***	bei Bestellung angeben:/please specify on order:/spécifier sur commande s.v.p.:				
			077159-A-V001	Austria without switch-over device (see TO-8)				
			077159-A-V002	Austria with switch-over device (see TO-8)				
			077159-D-V001	Germany without switch-over device (see TO-8)				
			077159-D-V002	Germany with switch-over device (see TO-8)				
			077159-F-V001	France without switch-over device (see TO-8)				
			077159-F-V002	France with switch-over device (see TO-8)				
			077911-V001	Japan without switch-over device (see TO-8)				
			077911-V002	Japan with switch-over device (see TO-8)				

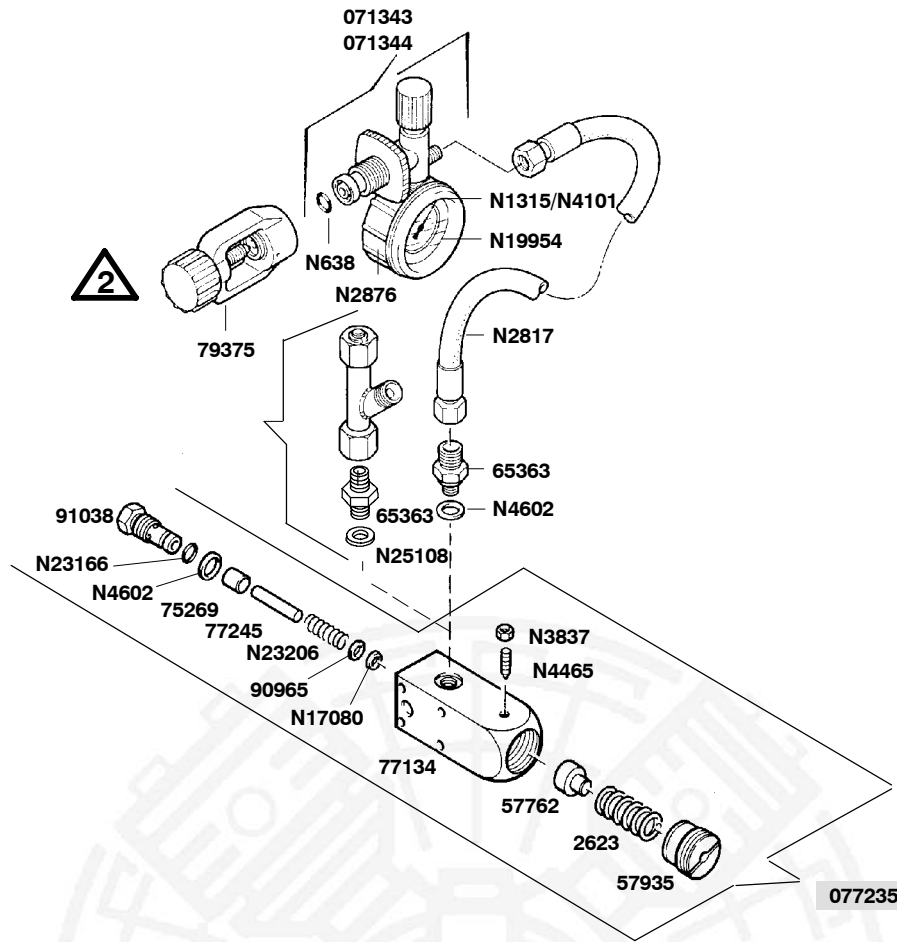

TO-7

Wartungssätze
Maintenance sets
Kits d'entretien
Bildtafel TO-7 **Druckhalteventil, Fülleinrichtung**
Figure TO-7 **Pressure maintaining valve, filling device**
Planche TO-7 **Soupage de maintien de pression, dispositif de remplissage**

Klasse/ Class/ Classe			Bestell-Nr. Part No. No. de cde.	Benennung	Designation	Dénomination	Gewicht Weight Poids (kg)	Abmessungen Dimensions Dimensions
a	b	c						
			071343	Füllventil	Filling valve	Robinet de remplissage		200 bar
			071344	Füllventil	Filling valve	Robinet de remplissage		300 bar
	X		072349	Reparatursatz für Füllv.	Repair kit for filling valve	Kit de rép. p. robinet de remp		
			073080	Verteiler	Distributor	Distributeur		
			077235	Druckhalteventil	Pressure maintaining v.	Clapet de maintien de press.	0.240	
			2623	Druckfeder	Spring	Ressort		
			57762	Federaufnahme	Spring seat	Siège de ressort		
			57935	Einstellschraube	Adjustment screw	Vis de réglage		
			65363	Schlauchnippel	Hose nipple	Raccord pour tuyau		UNIMAM
	X		75269	Ventilkolben	Valve piston	Piston de clapet	0.020	
			77134	Ventilkörper	Valve housing	Corps de clapet		
	X		77245	Zylinderstift	Pressure pin	Cheville cylindrique	0.005	
			79375	Internat. Füllanschluß	International connection	Raccord international		200 bar
			90965	Scheibe	Washer	Rondelle		
			91038	Druckhalteventilsitz	Valve seat	Siège du clap. maint. de pre.	0.025	
			N638	O-Ring	O-ring	Joint torique	0.005	Ø 11 x 2,5
			N781	Innensechskantschr.	Allen screw	Vis à six pans creux	0.015	M 6 x 60 DIN912
			N1315	Manometer	Pressure gauge	Manomètre	0.332	PN200
			N2817	Füllschlauch	Filling hose	Tuyau de remplissage		
			N2876	Schutzkappe	Protection cap	Chapeau de protection	0.036	
	X		N3837	Sechskantmutter	Hex. nut	Ecrou hexagonal		NM 4 DIN980
			N4101	Manometer	Pressure gauge	Manomètre	0.332	PN300
			N4465	Gewindestift	Stud	Vis sans tête	0.001	M 4 x 10 DIN553
	X		N25108	USIT-Ring	USIT-Ring	Joint USIT	0.001	
	X		N17080	Dichtung	Gasket	Joint		5 x 8 x 2.3
			N19954	Ersatzglas	Replacement glas	Verre de rEchange		
	X		N23166	O-Ring	O-ring	Joint torique	0.005	Ø 7 x1.5; NBR; 90 Sh.
			N23206	Druckfeder	Spring	Ressort		
			*	nur zusammen lieferbar	available only as a set	ne sont livrées qu'ensemble		
			**	Druck bei Bestellung angeben	Indicate pressure on order	Indiquer la pression à la commande		

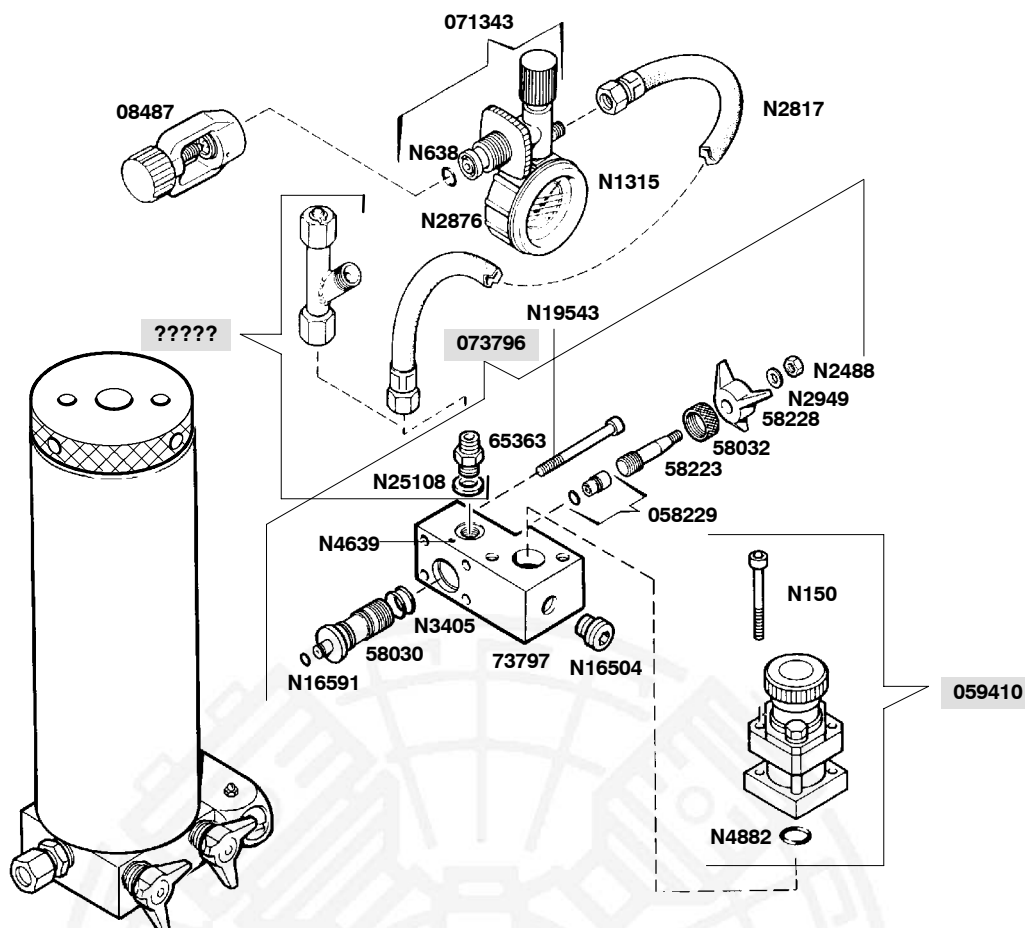

TO-8

Wartungssätze
Maintenance sets
Kits d'entretien
Bildtafel TO-8 Umschalteinrichtung PN200/PN300
Figure TO-8 Switch over device PN200/PN300
Planche TO-8 Dispositif sélecteur PN200/PN300

Klasse/ Class/ Classe			Bestell-Nr. Part No. No. de cde.	Benennung	Designation	Dénomination	Gewicht Weight Poids (kg)	Abmessungen Dimensions Dimensions
a	b	c						
			08487	Internat. Füllanschluß	International connection	Raccord international		
			014532	Verteiler	Distributor	Distributeur		
	X		058229	Spindelkolben kpl.	Spindle piston assy.	Piston de broche cpl.	0.005	
			059410	Sicherheitsventil	Safety valve	Soupape de sûreté	0.310	225 bar
			071343	Füllventil	Filling valve	Robinet de remplissage		PN200
			073796	Umschalteinrichtung kpl.	Switch over device assy.	Dispositif sélecteur cpl.		
			58030	Spindelaufnahme	Spindle carrier	Porte broche	0.054	
			58032	Sicherungsmutter	Lock nut	Contre-écrou	0.010	
			58223	Spindel	Spindle	Broche		
			58228	Knebelgriff	Tap	Manette	0.023	
			65363	UNIMAM-Verschraubung	Connection	Raccord		
			73797	Umschalteinrichtung	Switch-over block	Bloc sélecteur	0.254	
			N150	Innensechskantschraube	Allen screw	Vis à six pans creux		M8x60, DIN 912
			N638	O-Ring	O-ring	Joint torique	0.005	Ø 11 x 2,5
			N1315	Manometer	Pressure gauge	Manomètre	0.332	PN200
			N2488	Sechskantmutter, selbsts.	Hex. nut, self locking	Ecrou hex., auto-freinant	0.002	NM 5 DIN980
			N2817	Füllschlauch	Filling hose	Tuyau de remplissage		
			N2876	Schutzkappe	Protection cap	Capot de protection	0.036	
			N2949	Scheibe	Washer	Rondelle	0.005	Ø 5,3 DIN125
			N3405	O-Ring	O-ring	Joint torique	0.005	Ø 12,42 x 1,78
			N4602	USIT-Ring	USIT-ring	Joint USIT		U 14-18.7-1.5
			N4639	Zylinderkerbstift	Straight grooved pin	Goupille cylindrique cann.	0.001	2.5 x 12, DIN1473
			N4882	O-Ring	O ring	Joint torique		16x2
			N16504	Verschlusschraube	Cover screw	Vis de fermeture	0.006	VS-R 1/8-WD;G 1/8; St
	X		N16591	O-Ring	O-ring	Joint torique		Ø 5 x 1,5
			N19543	Innensechskantschraube	Allen screw	Vis à six pans creux	0.015	M 6 x 80 DIN912

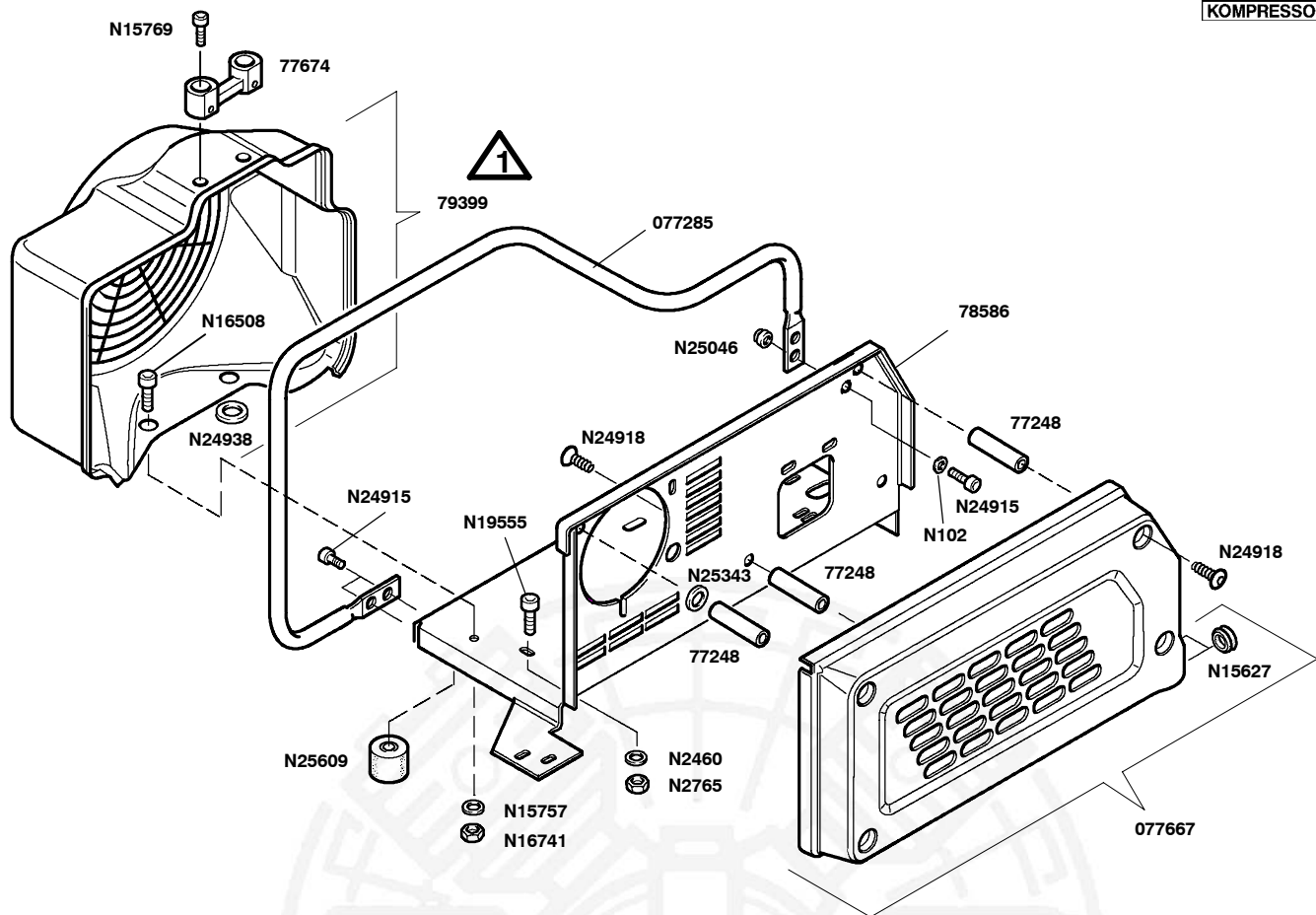

TO-9

Wartungssätze
Maintenance sets
Kits d'entretien

Bildtafel TO-9 **Rahmen mit Zubehör**
Figure TO-9 **Frame with accessories**
Planche TO-9 **Cadre avec accessoires**



ÄM 6553

Klasse/ Class/ Classe			Bestell-Nr. Part No.	Benennung	Designation	Dénomination	Gewicht Weight Poids (kg)	Abmessungen Dimensions Dimensions
a	b	c	No. de cde.					
			077285	Griff	Handle	Poignée		
			077667	Riemenschutz kpl.	V-belt cover assy.	Protection de courroie cpl.		
			77248	Bolzen	Bolt	Goujon		SW13;L63;PA6
			77674	Halterung	Bracket	Dixation		Füllventil; Lüfterschutz;
			78586	Rahmen	Frame	Cadre		RAL 7024; graphitgrau
			79399	Lüfterradschutz kpl.	Fanwheel cover	Protection de ventilateur		Oceanus
			N102	Scheibe	Washer	Rondelle	1 g	DIN 125;B 6.4;St;A3A
			N2460	Scheibe	Washer	Rondelle	7 g	DIN 9021;A 8.4;St;A3A
			N2765	Sechskantmutter	Hexagon nut	Ecrou hexagonal		DIN 980; M8; A3A
			N15627	Durchführungsstülpe	Grommet	Douille		DG21; AD28; ID21; H2
			N15757	Scheibe	Washer	Rondelle	7 g	DIN 125;B8.4;1.4571
			N15769	Zylinderschraube	Allen screw	Vis a six pans creux	6 g	DIN 912;M6x16;1.4571
			N16508	Zylinderschraube	Allen screw	Vis a six pans creux	12 g	DIN 912;M8x16;1.4571
			N16741	Sechskantmutter, selbsts	Hexagon nut, self-lock	Ecrou hexagonal, auto-frein		DIN 980; NM8; 1.4571
			N19555	Zylinderschraube	Allen screw	Vis a six pans creux		DIN 912;M8x60;8.8;A3A
			N24915	Linsenkopfschraube	Lens head allen screw	Vis à tête goutte-de-suif		ISO7380;M6x16
			N24918	Linsenkopfschraube	Lens head allen screw	Vis à tête goutte-de-suif		WN1451;K60x12
			N24938	Durchführungsstülpe	Grommet	Douille		AD24; ID14
			N25046	Endkappe	End cap	Chapeau		DI8;H13; H7; PVC
			N25343	Fächerscheibe	Washer	Rondelle		
			N25609	Schwingmetall	Vibration isolator	Amortisseur de vibration	,121 kg	D50;H45;40Shore;M10

			N24957	Winkelschraubendreher	Screw driver	Tournevis		Torx-1X25; CrVa
--	--	--	--------	-----------------------	--------------	-----------	--	-----------------

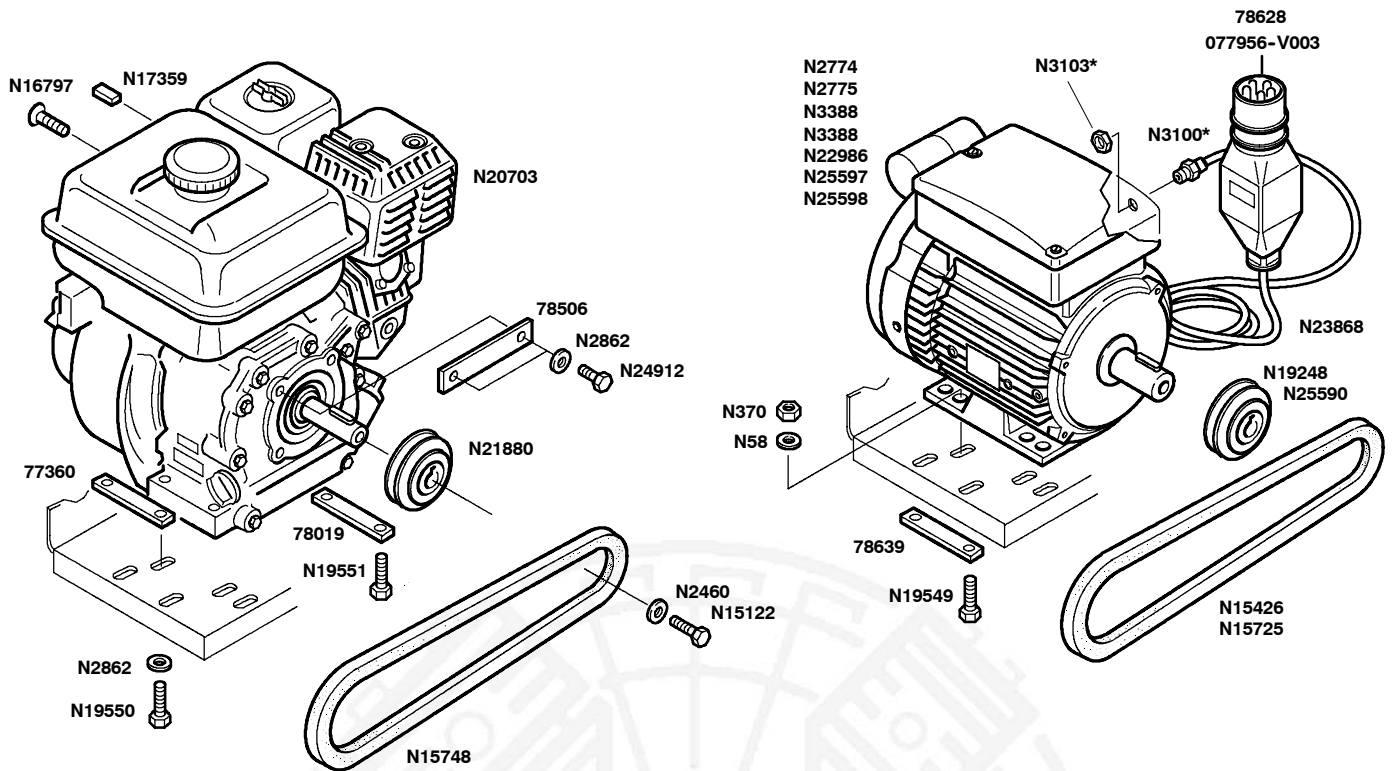

TO-10

Wartungssätze
Maintenance sets
Kits d'entretien
Bildtafel TO-10 Antriebsmotoren mit Zubehör
Figure TO-10 Driving motors with accessories
Planche TO-10 Moteurs d'entraînement avec équipement

Klasse/ Class/ Classe			Bestell-Nr. Part No. No. de cde.	Benennung	Designation	Dénomination	Gewicht Weight Poids (kg)	Abmessungen Dimensions Dimensions
a	b	c						
			077956-V003*	Motorschutzschalter	Motor protection switch	Interrupteur de prot. p. mot.		3kW; 220-240V
			77360	Leiste	Bracket	Entretoise		O2B
			78506	Scheibe	Washer	rondelle		
			78019	Leiste	Bracket	Entretoise		
			78639	Leiste	Bracket	Entretoise		
			78628*	Motorschutzschalter	Motor protection switch	Interrupteur de prot. p. mot.		3kW; 400V
			N58	Scheibe	Washer	Rondelle	2 g	DIN125;B 8.4;St;A3A
			N108	Federring	Spring washer	Rondelle-ressort	1 g	DIN127;A 8;St;A3A
			N370	Selbstsichernde Mutter	Hex. nut self-locking	Ecrou hexagonal auto-frein.		DIN980;NM8;8;A3A
			N2460	Scheibe	Washer	Rondelle	7 g	DIN 9021;A 8.4;St;A3A
			N2774	Drehstrommotor	Three phase motor	Moteur à courant triphasé		50-60 Hz, 3 kW;
			N2775	Wechselstrommotor	Single phase motor	Moteur à courant alternatif		50 Hz, 3 kW, 240 V
			N2862	Scheibe	Washer	Rondelle	7 g	DIN7349;A 8.4;St;A3A
			N3100*	Kabelverschraubung	Cable stuffing	Racc. presse-étoupe		Pg 16;m.Dichtg.
			N3103*	Gegenmutter	Counternut	Contre-ecrou		DIN46320;Pg 16;PA/GV
			N3388	Drehstrommotor	Three-phase motor	Moteur triphasé	13,50	50 Hz, 2.2 kW, 220 V
			N15122	Sechskantschraube	Hexagon screw	Vis hexagonale	,011 kg	8.8 DIN933
	X		N15426	Keilriemen 60 Hz	H-belt 60 Hz	Courroie trapezoidale 60 Hz	,065 kg	DIN7753;SPZ;Lw 900
	X		N15725	Keilriemen 50 Hz	V-belt 50 Hz	Courroie trapezoidale 50 Hz	,06 kg	DIN7753;SPZ;Lw 925
	X		N15748	Keilriemen Benzinmotor	V-belt petrol engine	Courroie trap. moteur à ess.	,06 kg	DIN7753;SPZ;Lw 912
			N16797	Kreuzlochschraube	Capsten headed screw	Vis a tete percee en croix	5 g	DIN404;M5x25;5.8;A3A
			N17359	Schutzkappe	Protection cap	Capot protecteur		
			N19248	Keilriemenscheibe 50Hz	V-belt pulley 50 Hz	Poulie a gorge 50 Hz	1,1 kg	SPZ;dw100;1-ril.;ID24
			N19549	Innensechskantschr.	Allen screw	Vis six pans creux		DIN912;M8x30;12.9
			N19550	Innensechskantschr.	Allen screw	Vis six pans creux		DIN912;M8x35;12.9
			N19551	Innensechskantschr.	Allen screw	Vis six pans creux		DIN912;M8x40;12.9
			N20703	Benzin-Motor	Gasoline engine	Moteur à essence	13,50	Honda 4,0 kW
			N21880	Keilriemensch. Benzinm.	V-belt pulley petrol eng.	Poulie a gorge moteur à ess.		SPZ;dw80;1-ril.;ID19
			N22986	Wechselstrommotor	Single phase motor	Moteur à courant alternatif		50 Hz, 3 kW, 230 V
			*	nur Drehstrommotor	Three phase motor only	Seulem. pour moteur tri-ph		
			N23868*	Gummischlauchleitung	Cable	Cable		5 m; H07RN-F; 5x2,5

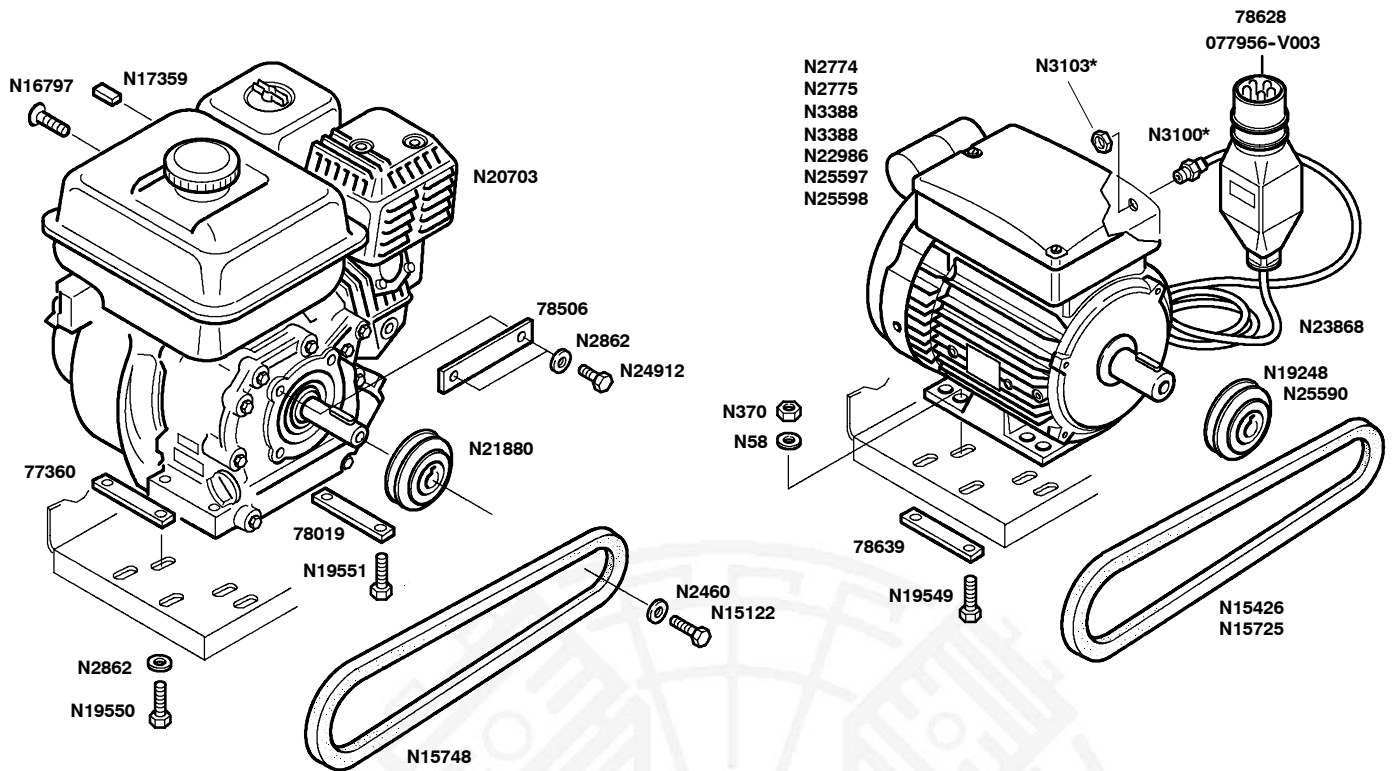

TO-10

Wartungssätze
Maintenance sets
Kits d'entretien

Bildtafel TO-10 Antriebsmotoren mit Zubehör
Figure TO-10 Driving motors with accessories
Planche TO-10 Moteurs d'entraînement avec équipement

Klasse/ Class/ Classe			Bestell-Nr. Part No. No. de cde.	Benennung	Designation	Dénomination	Gewicht Weight Poids (kg)	Abmessungen Dimensions Dimensions
a	b	c						
			N25590	Keilriemenscheibe 60Hz	V-belt pulley 60 Hz	Poulie à gorge, moteur 60 Hz	,531 kg	SPZ;dw80;1-riL.;ID24
			N25597	Wechselstrommotor	Single phase motor	Moteur à courant alternatif		60 Hz, 3 kW, 230 V
			N25598	Wechselstrommotor	Single phase motor	Moteur à courant alternatif		60 Hz, 3 kW, 110 V
			N24912	Sechskantschraube	Hexagon screw	Vis hexagonale		DIN933;5/16;24 UNFx1"
			N3388	Drehstrommotor	Three-phase motor	Moteur triphasé		50 HZ, 2.2 kW, 220 V
			*	nur Drehstrommotor	Three phase motor only	Seulem. pour moteur tri-ph		

			N25238	Keilriemenvorspannungs-Meßgerät	V-belt tension meter	mesure de prétension de la courroie trapézoïdale		
--	--	--	--------	---------------------------------	----------------------	--	--	--

