

ERSATZTEILLISTE
SPARE PARTS CATALOGUE
CATALOGUE DES PIECES

TMV3-1/0

Atemluft-Kompressoranlagen
Breathing air compressor units
Groupes compresseurs à air respirable

Mini-Verticus 3

Auflage / edition / édition 10/ 2006

BAUER KOMPRESSOREN GmbH

Postfach 710260 D-81452 München Tel. 089/78049-0 Fax 089/78049167

HINWEIS

Diese Ersatzteilliste ist für unterschiedliche Konfigurationen gültig; Der tatsächliche Lieferumfang kann insbesondere bei den Anbau- und Zubehörteilen von den dargestellten Baugruppen und Teilen abweichen.

NOTE

This parts list covers different configurations; the delivery scope, especially for the mounting and accessory parts may differ from the assemblies and parts shown.

NOTE

Cette liste de pièces est valable pour des configurations diverses; il est donc possible que les pièces et les assemblages livrés soient différents des pièces et assemblages indiqués, en particulier les pièces destinées au montage et les accessoires.

Ersatzteilliste
Spare parts catalogue
Liste des pièces

TMV3
TMV3
TMV3

Mini-Verticus 3 Kompressoranlagen
Mini-Verticus 3 Compressor units
Groupes compresseurs Mini-Verticus 3



Baugruppe	Assembly	Assemblage	Code
Kompressorblock	Compressor block	Bloc compresseur	A1.7
Filtersystem	Filter system	Système de filtration	B64.0
Kondensat-Ablaufautomatik	Automatic condensate drain	Purge automatique des condensats	C75.0
Armaturentafel	Instrument panel	Instruments de gonflage	D17.0
Rahmen	Frame	Châssis	E28.0
Antriebssystem	Drive system	Système d'entraînement	F16.0
Kompressorsteuerung	Compressor control system	Commande électrique	G68.0

Änder.-Nr. Change no. No. de change	Datum Date	Änderung	Change	Changement
0	01.10.2006	Grundausgabe	Basic edition	Edition de base

Wichtige Hinweise für Teilebestellung:

Bestell-Nr., die mit der Ziffer 0 beginnen, bezeichnen Baugruppen, die komplett geliefert werden. Teile ohne Bestell-Nr. sind nur zur Information für die Montage aufgeführt. Sie sind nicht als Ersatzteil erhältlich. Bei Ersatzteilbestellungen erwarten Sie unsere richtige Lieferung; deshalb benötigen wir von Ihnen folgende Angaben (siehe unten gezeigtes Typenschild):

1. Modellbezeichnung, Fabrik-Nr. sowie Fertigungsstand von Anlage/Block
2. Stückzahlen
3. Benennung und Best.-Nr. des gewünschten Teils

Bestell-Beispiel:

Für Kompressorblock ...
Fabrik-Nr. 524-0528/1/2 drei Dichtungen
8263-090

Important notes for spare parts orders:

Part nos. beginning with digit 0 indicate parts available as complete assemblies. Parts without part no. are indicated for assembly reference, only. These parts are not available as single parts. When placing an order for spare parts, please give the following items so as to ensure our correct delivery (see identification plate shown below):

1. Model, serial no. as well as design standard of unit/block
2. Quantity required
3. Name and part no.

Example for order:

For compressor block ...
serial no. 524-0528/1/2, three gaskets
8263-090

Avis important pour la commande de pièces:

Les nos. de commande commençant par le chiffre 0 indiquent les pièces livrées au complet. Les pièces sans no. de commande sont indiquées uniquement pour information de montage. Elles ne sont pas livrées individuellement. Pour que la livraison de pièces de rechange corresponde à la commande, veuillez bien nous fournir les données suivantes (voir plaque d'identité ci-dessous):

1. Modèle, no. de série et standard de construction de bloc compresseur/groupe
2. Quantité désirée
3. Dénomination et no. de commande de la pièce désirée

Exemple de commande:

Pour bloc compresseur ...
no. de série 524-0528/1/2, trois joints no. de cde. 8263-090



Wartungssätze

- a =Wartungssatz 1000 h
- b =Wartungssatz 2000 h
- c =Wartungssatz 4000 h



Maintenance kit

- a = Maintenance kit 1000 h
- b = Maintenance kit 2000 h
- c = Maintenance kit 4000 h



Kits de pièces d'entretien :

- a = Kit d'entretien 1000 h
- b = Kit d'entretien 2000 h
- c = Kit d'entretien 4000 h

In den Spalten sind die im entsprechenden Satz enthaltenen Teile angekreuzt. Bitte beachten, daß die höheren Sätze die untergeordneten nicht beinhalten, d.h. für eine 4000-Stunden-Wartung wird 1x Satz a, 1x Satz b und 1x Satz c benötigt.

The columns contain the parts that are included in the respective parts set. Please note that the higher graded kits do not include the lower ones, i.e. for a 4000 hours maintenance, one kit a, one kit b plus one kit c are required.

Les pièces contenues dans les kits correspondants sont marquées d'une croix dans les colonnes. Veuillez observer que les kits supérieurs ne contiennent pas les kits subordonnés, c'est-à-dire pour un entretien de 4000 heures il faut avoir 1x kit a, 1x kit b et 1x kit c.

Anmerkungen zur Identifikation:
Remarks for identification:
Remarques pour l'identification:

Modell/Model/Modèle		Fabrik-Nr./Serial no./Numéro de série	
<input type="text"/>		<input type="text"/>	
<input type="checkbox"/>	<input type="checkbox"/>	<input type="checkbox"/>	<input type="checkbox"/>
Volumenstrom m ³ /min	n/min.	Jahr	Year
Free air delivery Scfm	r.p.m.	<input type="text"/>	<input type="text"/>
Betriebsüberdruck bar	kW	<input type="text"/>	<input type="text"/>
Max. working press. psig		<input type="text"/>	<input type="text"/>

Fertigungsstand / Modification no. / No. de modification
 Anlage/Unit/Groupe
 Kompressorblock/ Compressor block/ Bloc compresseur



ACHTUNG

Nur Schrauben und Stiftschrauben der Qualität 8.8 verwenden!



ATTENTION

Use only screws and studs in quality 8.8! This quality is equivalent to SAE J 429 d grade 5.



ATTENTION

N'utiliser que des vis et des goujons filetés de la qualité 8.8!

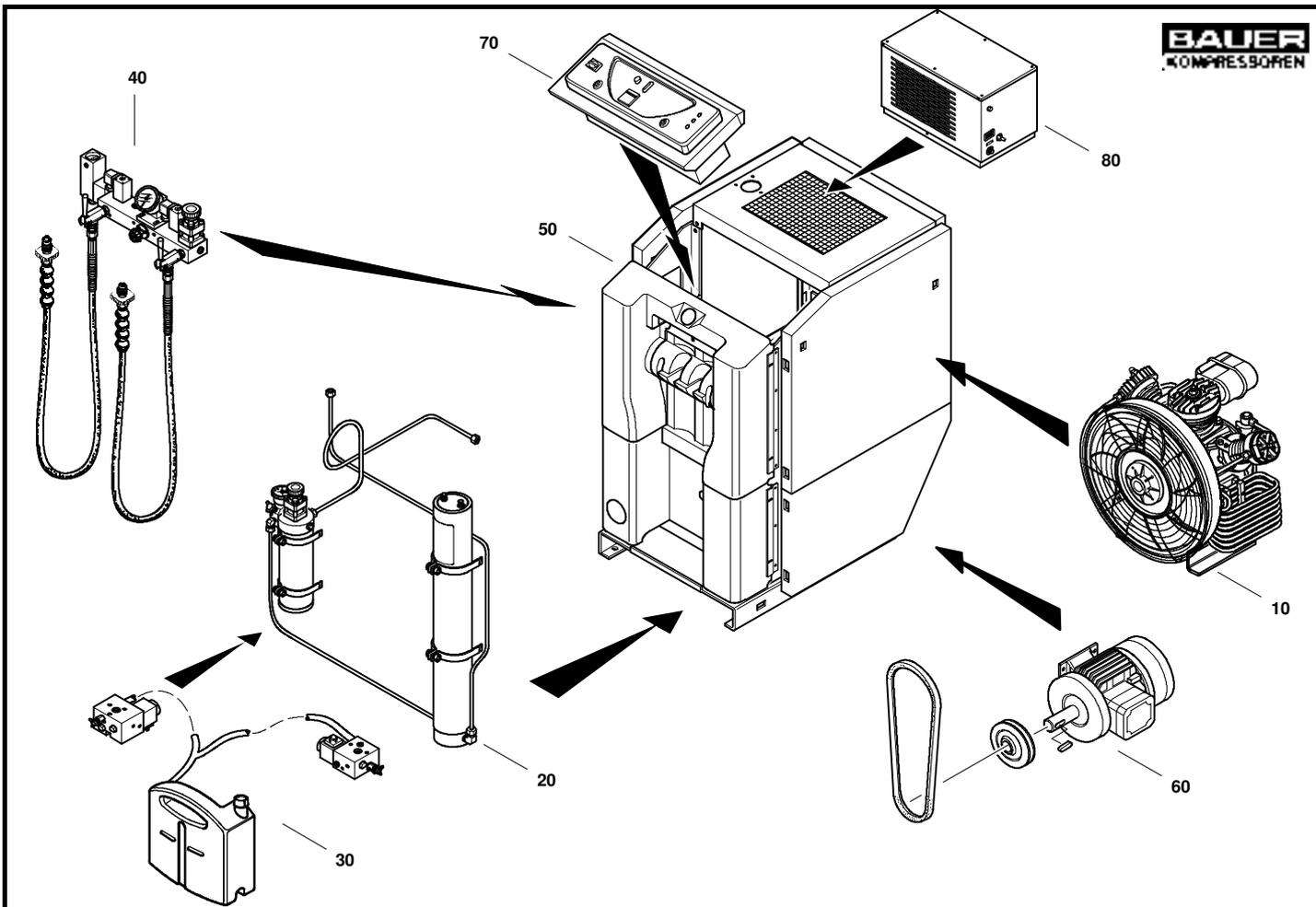

Wartungssätze
Mainenance kits
Kits d'entretien

Baugruppe
Assembly
Assemblage

Mini-Verticus 3
Mini-Verticus 3
Mini-Verticus 3

Mini-Verticus 3 Kompressoranlagen
Mini-Verticus 3 Compressor units
Groupes compresseurs Mini-Verticus 3

TMV3- 1

Klasse/ Class/ Classe			Pos.	Ersatzteilliste Spare parts catalog Liste des pièces détachées	Benennung	Designation	Dénomination
a	b	c					
			10	A1.7	Kompressorblock	Compressor block	Bloc compresseur
			20	B64.0	Filtersystem	Filter system	Système de filtration
			30	C75.0	Kondensatautomatik	Automatic condensate drain	Purge auto. des condensats
			40	D17.0	Armaturentafel	Instrument panel	Tableau de gonflage
			50	E28.0	Rahmen und Verkleidung	Frame assy	Châssis et carrosserie
			60	F16.0	Drehstrommotor + Motorzubehör	Electric motor + accessories	Moteur électrique + accessoires
			70	G68.0	Kompressorsteuerung	Control unit	Commande électronique

Zubehör / Accessories / Accessoires

			80	G64.0	Air-Kool	Air-Kool	Air-Kool
--	--	--	----	-------	----------	----------	----------

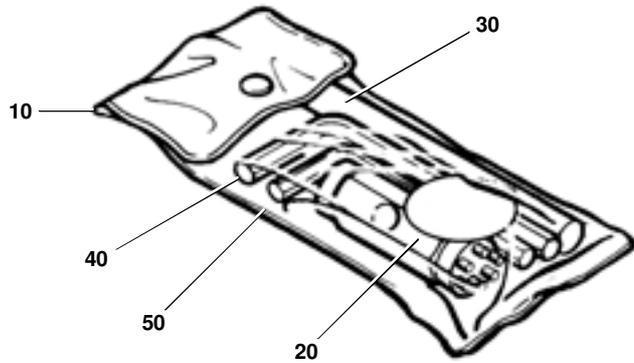
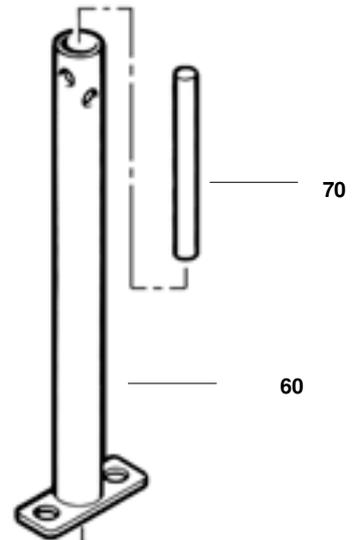
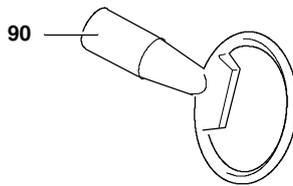
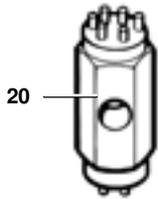
 Wartungssätze
 Maintenance sets
 Kits d'entretien

 Baugruppe 84161
 Assembly 84161
 Assemblage 84161

 Werkzeug und Zubehör
 Tools and accessories
 Outils et accessoires

TMV3- 2

Klasse/ Class/ Classe			Pos.	Bestell-Nr. Part No. No. de cde.	Benennung	Designation	Dénomination
a	b	c					
			10	78469	Werkzeugtasche	bag	poche
			20	82048	Ventilkopfschlüssel	valve head key	clef de culasse
			30	77781	Stift	pin	levier
			40	N2777	Winkelschraubendreher	allen key	clef allen
			50	N2776	Winkelschraubendreher	allen key	clef allen
			60	66690	Filterschlüssel	filter key	clef de filtre
			70	66691	Stange	bar	barre
			80	N28342	Halterung	support	support
			90	N16230	Schlüssel	pipe key	clef

Wichtige Hinweise für Teilebestellung:

Bestell-Nr., die mit der Ziffer 0 beginnen, bezeichnen Baugruppen, die komplett geliefert werden. Teile ohne Bestell-Nr. sind nur zur Information für die Montage aufgeführt. Sie sind nicht als Ersatzteil erhältlich. Bei Ersatzteilbestellungen erwarten Sie unsere richtige Lieferung; deshalb benötigen wir von Ihnen folgende Angaben (siehe unten gezeigtes Typenschild):

1. Modellbezeichnung, Fabrik-Nr. sowie Fertigungsstand von Anlage/Block
2. Stückzahlen
3. Benennung und Best.-Nr. des gewünschten Teils

Bestell-Beispiel:

Für Kompressorblock ...
Fabrik-Nr. 5124-0528/1/2 drei Dichtungen
8263-090

Important notes for spare parts orders:

Part nos. beginning with digit 0 indicate parts available as complete assemblies. Parts without part no. are indicated for assembly reference, only. These parts are not available as single parts. When placing an order for spare parts, please give the following items so as to ensure our correct delivery (see identification plate shown below):

1. Model, serial no. as well as design standard of unit/block
2. Quantity required
3. Name and part no.

Example for order:

For compressor block ...
serial no. 5124-0528/1/2, three gaskets
8263-090

Avis important pour la commande de pièces:

Les nos. de commande commençant par le chiffre 0 indiquent les pièces livrées au complet. Les pièces sans no. de commande sont indiquées uniquement pour information de montage. Elles ne sont pas livrées individuellement. Pour que la livraison de pièces de rechange corresponde à la commande, veuillez bien nous fournir les données suivantes (voir plaque d'identité ci-dessous):

1. Modèle, no. de série et standard de construction de bloc compresseur/groupe
2. Quantité désirée
3. Dénomination et no. de commande de la pièce désirée

Exemple de commande:

Pour bloc compresseur ...
no. de série 5124-0528/1/2, trois joints no. de cde. 8263-090



Wartungssätze

	Atemluft/Industrie
a = Wartungssatz	500/1000 h
b = Wartungssatz	1000/2000 h
c = Wartungssatz	2000/4000 h



Maintenance kit

	Breathing air/industry
a = Maintenance kit	500/1000 h
b = Maintenance kit	1000/2000 h
c = Maintenance kit	2000/4000 h



Kits de pièces d'entretien :

	Air respirable/industrie
a = Kit d'entretien	500/1000 h
b = Kit d'entretien	1000/2000 h
c = Kit d'entretien	2000/4000 h

In den Spalten sind die im entsprechenden Satz enthaltenen Teile angekreuzt. Bitte beachten, daß die höheren Sätze die untergeordneten nicht beinhalten, d.h. für eine 4000-Stunden-Wartung wird 1x Satz a, 1x Satz b und 1x Satz c benötigt.

The columns contain the parts that are included in the respective parts set. Please note that the higher graded kits do not include the lower ones, i.e. for a 4000 hours maintenance, one kit a, one kit b plus one kit c are required.

Les pièces contenues dans les kits correspondants sont marquées d'une croix dans les colonnes. Veuillez observer que les kits supérieurs ne contiennent pas les kits subordonnés, c'est-à-dire pour un entretien de 4000 heures il faut avoir 1x kit a, 1x kit b et 1x kit c.

Anmerkungen zur Identifikation:
Remarks for identification:
Remarques pour l'identification:

Modell/Model/Modèle		Fabrik-Nr./Serial no./Numéro de série	
<input type="checkbox"/> - <input type="checkbox"/> / <input type="checkbox"/> / <input type="checkbox"/>		Jahr / Year <input type="text"/> n/min. / r.p.m. <input type="text"/> kW <input type="text"/>	
Volumenstrom m ³ /min	<input type="text"/>	KB 73708 CE	Fertigungsstand / Modification no. / No. de modification <input type="text"/>
Free air delivery Scfm	<input type="text"/>		Anlage/Unit/Groupe <input type="text"/>
Betriebsüberdruck bar	<input type="text"/>		Kompressorblock/ Compressor block/ Bloc compresseur <input type="text"/>
Max. working press. psig	<input type="text"/>		



ACHTUNG

Nur Schrauben und Stiftschrauben der Qualität 8.8 verwenden!



ATTENTION

Use only screws and studs in quality 8.8! This quality is equivalent to SAE J 429 d grade 5.



ATTENTION

N'utiliser que des vis et des goujons filetés de la qualité 8.8!

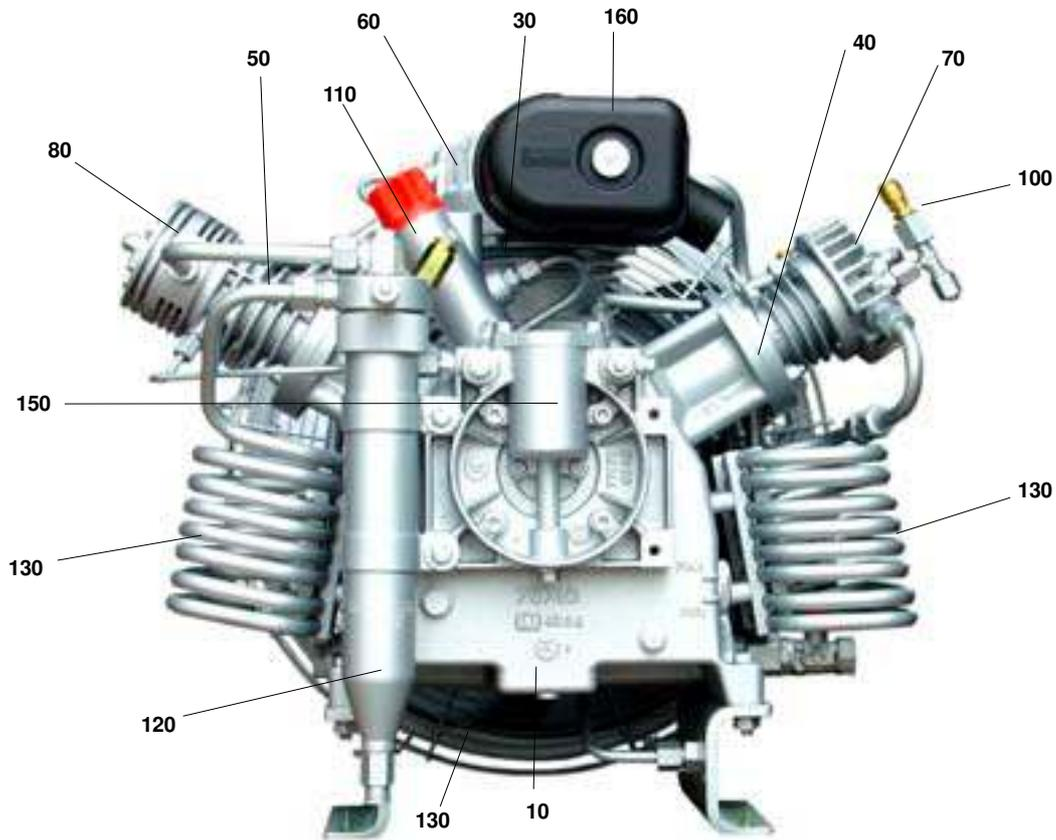

Wartungssätze
 Maintenance sets
 Kits d'entretien

Baugruppe IK100-V001
 Assembly IK100-V001
 Assemblage IK100-V001

IK100-Kompressorblock
 IK100 compressor block
 IK100 bloc compresseur

IK100

Klasse/ Class/ Classe			Pos.	Bestell-Nr. Part No. No. de cde.	Anz. Qty. Qté.	Benennung	Designation	Dénomination
a	b	c						
			10	076743	1	Kurbelgehäuse	crankcase	carter
			20	83452	1	Triebwerk	driving gear	embielage
			30	066665	1	Zylinder	cylinder	cyindre
			40	062899	1	Zylinder	cylinder	cyindre
			50	83400	1	Zylinder	cylinder 3. stage	cyindre 3. étage
			60	81632	1	Ventilkopf	valve head 1st stage	culasse 1er étage
			70	069955	1	Ventilkopf	valve head	culasse
			80	82096	1	Ventilkopf	valve head	culasse
			90	82552	1	Schwungrad	flywheel	roue volant
			100	81802	1	Sicherheitsventil 9 bar	safety valve 9 bar	soupape de sûreté 9 bar
			110	072935	1	Sicherheitsventil 60 bar	safety valve 60 bar	soupape de sûreté 60 bar
			120	81799	1	Zwischenfilter	inter filter	filtre intermédiaire
			130	83453	1	Kühlung	cooling system	refroidissement
			140	81574	1	Zubehör	accessories	accessoires
			150	83417	1	Druckölschmierung	lubricating system	lubrification
			160	79577	1	Ansaugfilter	intake filter	filtre d'aspiration

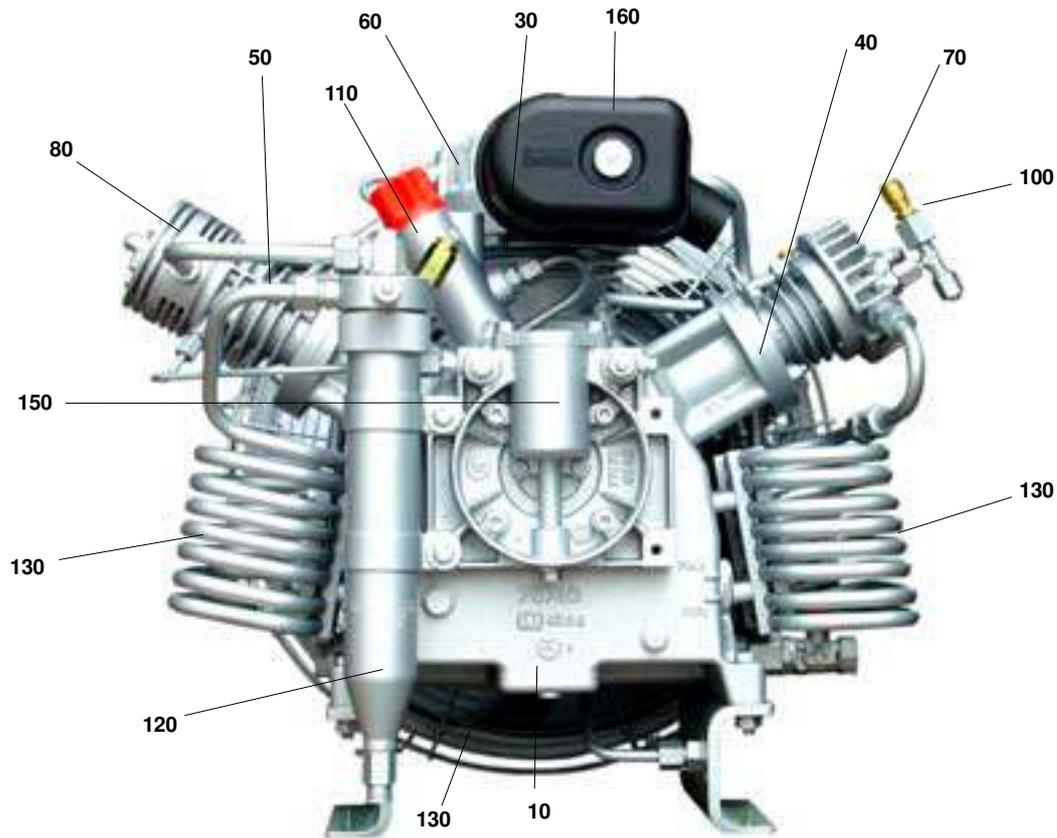

Wartungssätze
 Maintenance sets
 Kits d'entretien

Baugruppe IK120-V001
 Assembly IK120-V001
 Assemblage IK120-V001

IK120-Kompressorblock
 IK120 Compressor Block
 IK120 Bloc compresseur

IK120

Klasse/ Class/ Classe			Pos.	Bestell-Nr. Part No. No. de cde.	Anz. Qty. Qté.	Benennung	Designation	Dénomination
a	b	c						
			10	076743	1	Kurbelgehäuse	crankcase	carter
			20	83399	1	Triebwerk	driving gear	embiellage
			30	80826	1	Zylinder	cylinder	cylindre
			40	062899	1	Zylinder	cylinder	cylindre
			50	83400	1	Zylinder	cylinder 3. stage	cylindre 3. étage
			60	80688	1	Ventilkopf	valve head 1st stage	culasse 1er étage
			70	069955	1	Ventilkopf	valve head	culasse
			80	82096	1	Ventilkopf	valve head	culasse
			90	82552	1	Schwungrad	flywheel	roue volant
			100	81802	1	Sicherheitsventil 9 bar	safety valve 9 bar	soupape de sûreté 9 bar
			110	072935	1	Sicherheitsventil 60 bar	safety valve 60 bar	soupape de sûreté 60 bar
			120	81799	1	Zwischenfilter	inter filter	filtre intermédiaire
			130	83456	1	Kühlung	cooling system	refroidissement
			140	81567	1	Zubehör	accessories	accessoires
			150	83417	1	Druckölschmierung	lubricating	lubrification
			160	79577	1	Ansaugfilter	intake filter	filtre d'aspiration

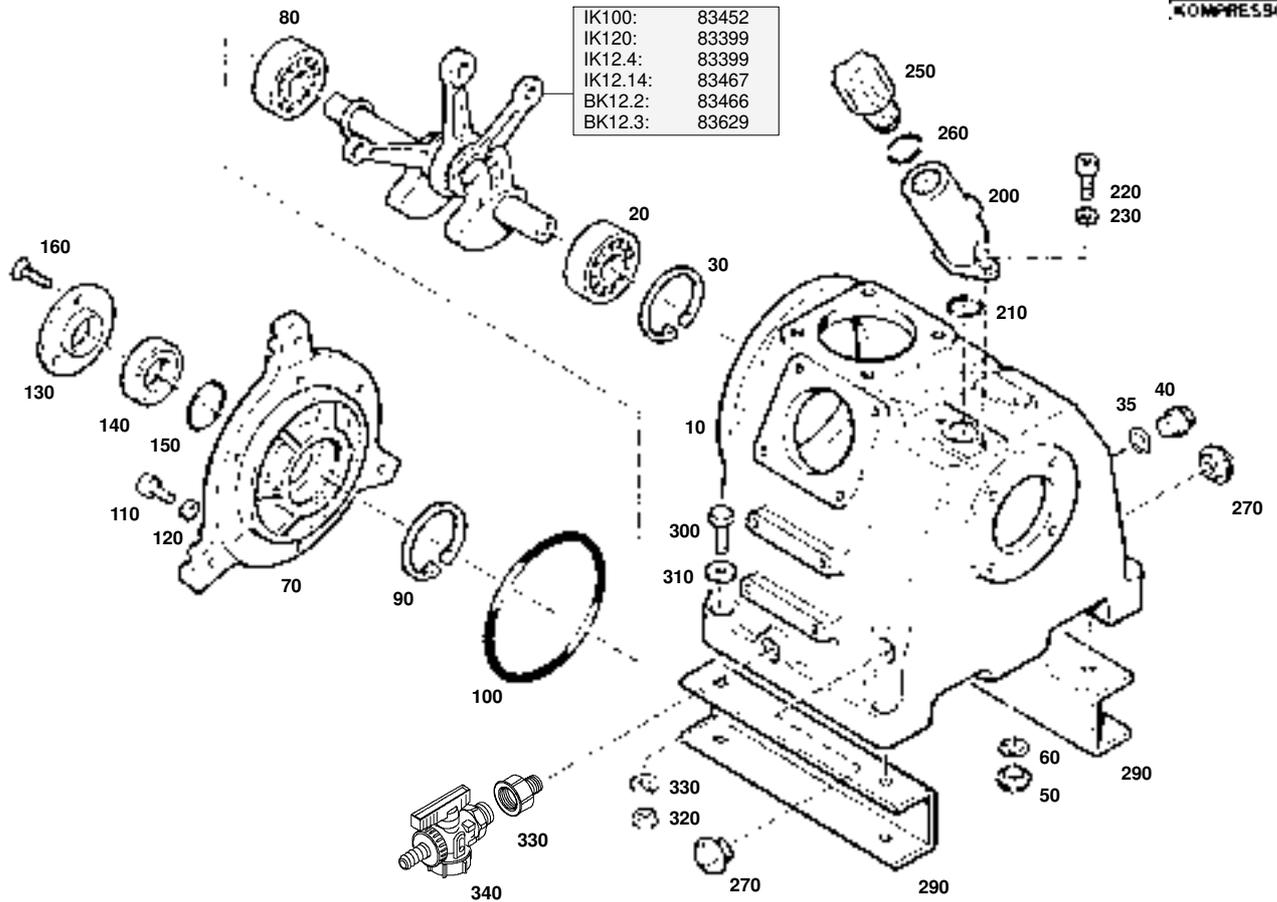

Wartungssätze
Maintenance sets
Kits d'entretien

Baugruppe 076743 Kurbelgehäuse, m. Zubehör, Triebwerk
Assembly 076743 Crankcase with accessories, driving gear
Assemblage 076743 Carter avec accessoires, embiellage

A1.7- 1

Klasse/ Class/ Classe			Pos.	Bestell-Nr. Part No. No. de cde.	Anz. Qty. Qté.	Benennung	Designation	Dénomination
a	b	c						
			10	76740	1	Kurbelgehäuse	crankcase	carter
			20	N2638	1	Zylinderrollenlager	cylindrical roller bearing	roulement à rouleaux
			30	N2635	1	Sicherungsring	circlip ring	rondelle de sûreté
X			35	N4261	1	Dichtring	gasket	joint
			40	N2796	1	Verschlußschraube	plug	bouchon fileté
			50	N4570	1	Verschlußschraube	plug	bouchon fileté
			60	N1316	1	Dichtring	gasket	joint
			70	66209	1	Lagerdeckel	bearing cap	couvercle de palier
			80	N15406	1	Zylinderrollenlager	cylindrical roller bearing	roulement à rouleaux
			90	N2635	1	Sicherungsring	circlip ring	rondelle de sûreté
			100	N15265	1	O-Ring	o-ring	joint torique
			110	N756	6	Sechskantschraube	hexagon screw	vis hexagonale
			120	N58	6	Scheibe	washer	rondelle
			130	66684	1	Deckel	cover	couvercle
			140	N170	1	Wellendichtring	shaft seal	bague d'étanchéité
			150	N3745	1	O-Ring	o-ring	joint torique
			160	N16128	3	Senkschraube	countersunk screw	vis à tête fraisée
			200	73830	1	Öleinfüllstutzen	oil filling pipe	tubulure de remplissage
			210	N4776	1	O-Ring	o-ring	joint torique
			220	N88	2	Sechskantschraube	hexagon screw	vis hexagonale
			230	N58	2	Scheibe	washer	rondelle
			250	61054	1	Verschlußschraube	plug	bouchon fileté
			260	N15412	1	O-Ring	o-ring	joint torique
			270	N25475	2	Ölstandsauge	oil sight gauge	regard d'huile
			290	78038	2	Kompressorfuß	support	ped de compresseur
			300	N350	4	Sechskantschraube	hexagon screw	vis hexagonale
			310	N16	4	Scheibe	washer	rondelle
			320	N176	4	Federring	spring washer	rondelle-ressort
			330	N177	4	Sechskantmutter	hexagon nut	écrou hexagonal

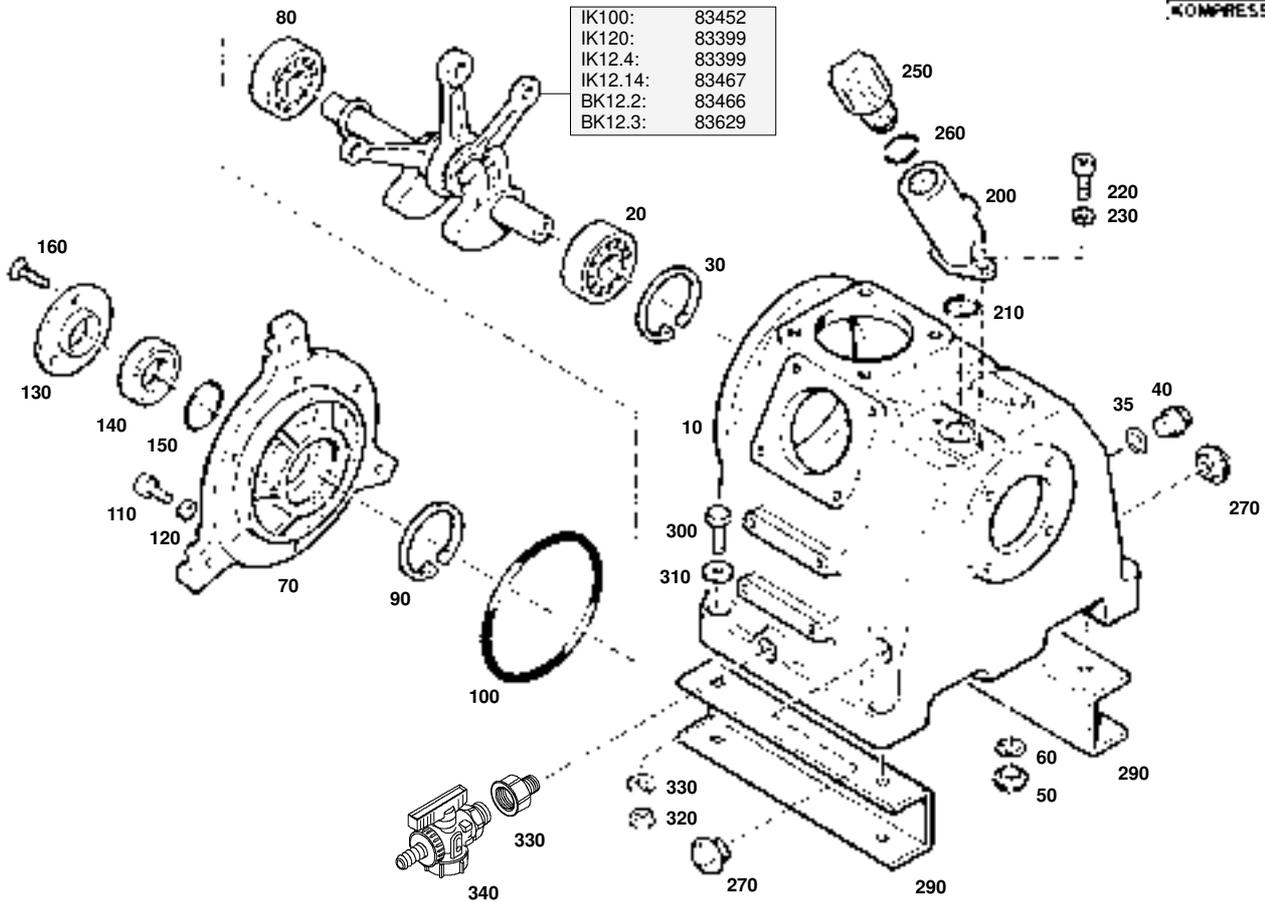

Wartungssätze
Maintenance sets
Kits d'entretien

Baugruppe 076743 Kurbelgehäuse, m. Zubehör, Triebwerk
 Assembly 076743 Crankcase with accessories, driving gear
 Assemblage 076743 Carter avec accessoires, embiellage

A1.7- 1

Klasse/ Class/ Classe			Pos.	Bestell-Nr. Part No. No. de cde.	Anz. Qty. Qté.	Benennung	Designation	Dénomination
a	b	c						
			330	N2375	1	Verschraubung	coupling	raccord
			340	N25638	1	Kugelhahn	ball valve	vanne

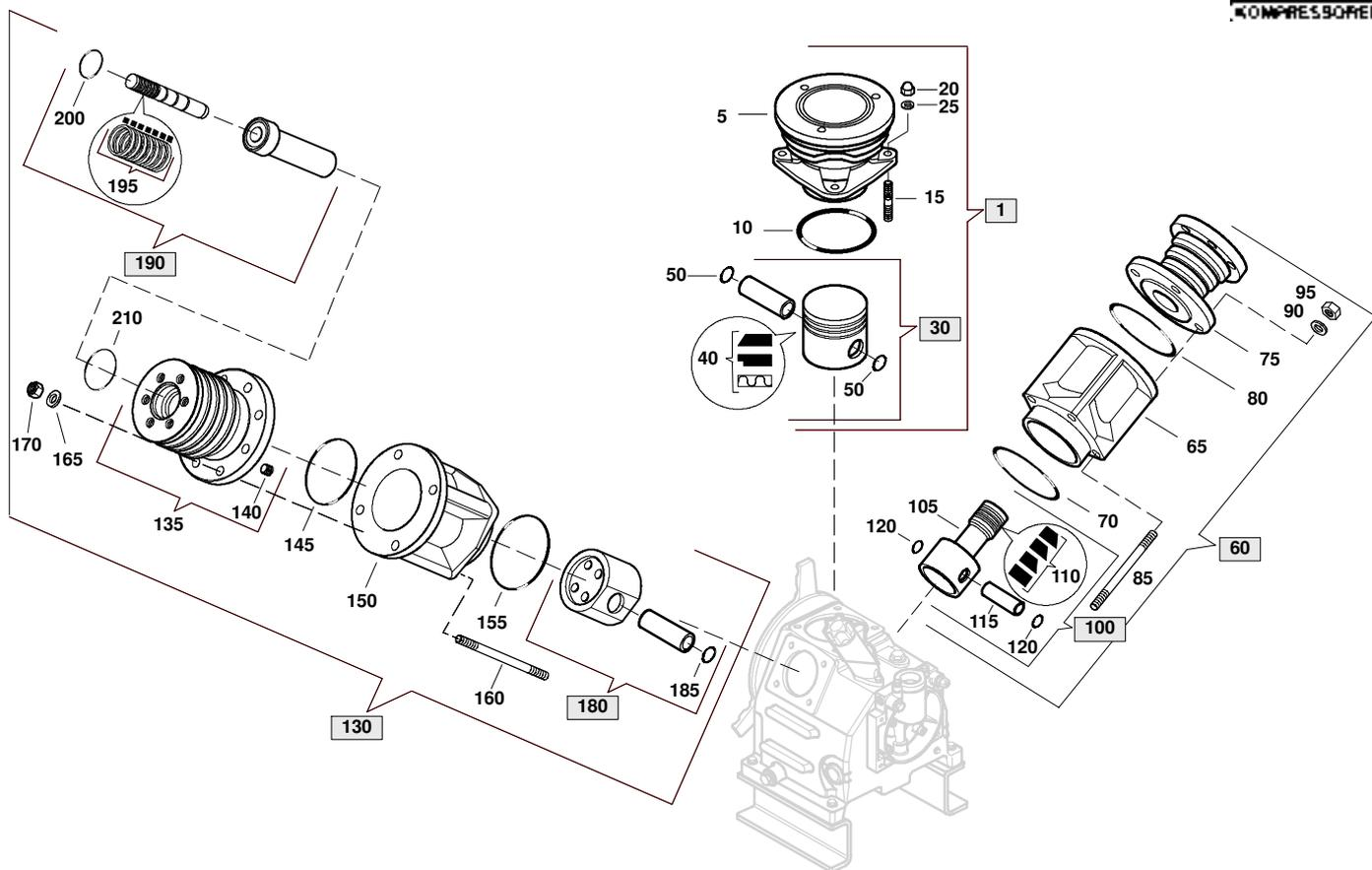



Wartungssätze
Maintenance sets
Kits d'entretien

Baugruppe Zylinder und Kolben, IK100
Assembly Cylinders and pistons, IK100
Assemblage Cylindres et pistons, IK100

A1.7- 2

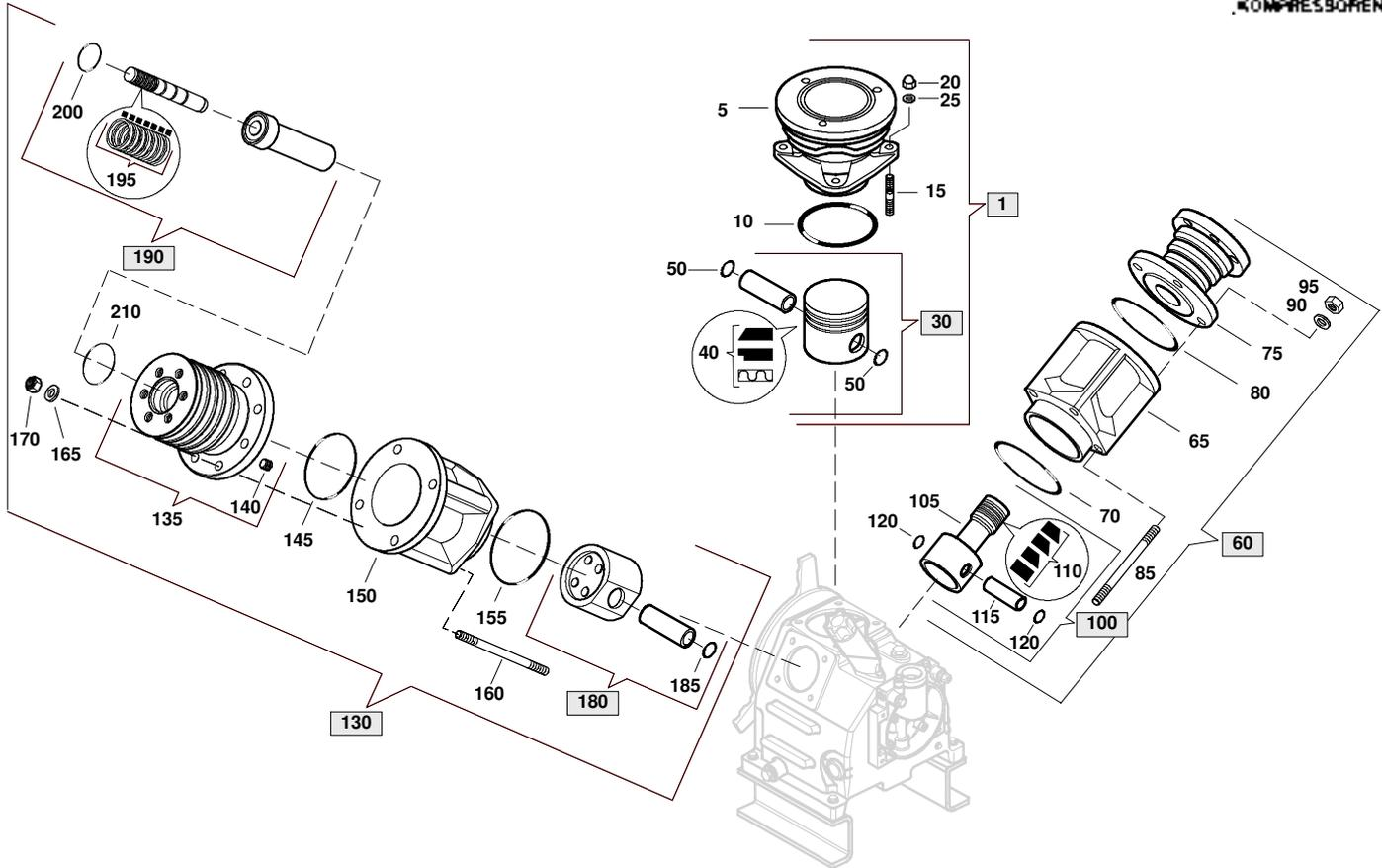
Klasse/ Class/ Classe			Pos.	Bestell-Nr. Part No. No. de cde.	Anz. Qty. Qté.	Benennung	Designation	Dénomination
a	b	c						
			1	066665	1	Zylinder kpl. 1.Stufe	cylinder assy. 1st stage	cylindre cpl. 1er étage
			5	66663	1	Zylinder	cylinder	cylindre
		X	10	N4654	1	O-Ring	o-ring	joint torique
			15	N215	4	Stiftschraube	stud	goujon fileté
		X	20	N370	4	Selbstsichernde Mutter	hexagon nut self-locking	écrou hexagonal auto-fr.
			25	N58	4	Scheibe	washer	rondelle
			30	069948	1	Kolben kpl.	piston cpl.	piston cpl.
			40	N3856	1	Kolbenringsatz	piston ring set	jeu des segments
			50	N484	2	Sicherungsring	circlip ring	rondelle de sûreté
			60	062899	1	Zylinder kpl. 2.Stufe	cylinder assy. 2nd stage	cylindre cpl. 2e étage
			65	83404	1	Führungszylinder	guide cylinder	cylindre guide
		X	70	N2640	1	O-Ring	o-ring	joint torique
			75	62477	1	Zylinder	cylinder	cylindre
		X	80	N7063	1	O-Ring	o-ring	joint torique
			85	N2790	4	Stiftschraube	stud	goujon fileté
			90	N58	4	Scheibe	washer	rondelle
		X	95	N370	4	Selbstsichernde Mutter	hexagon nut self-locking	écrou hexagonal auto-fr.
			100	072249	1	Kolben kpl.	piston cpl.	piston cpl.
			105	62487	1	Kolben	piston	piston
			110	N2647	1	Kolbenringsatz	piston ring set	jeu de segments
			115	N1429	1	Kolbenbolzen	piston pin	axe de piston
			120	N484	2	Sicherungsring	circlip ring	rondelle de sûreté
			130	83400	1	Zylinder kpl. 3.Stufe	cylinder assy. 3rd stage	cylindre cpl. 3e étage
			135	82480	1	Zylinder	cylinder	cylindre
			140	N27318	1	Verschlußstopfen	screw	bouchon
		X	145	N7063	1	O-Ring	o-ring	joint torique
			150	83404	1	Führungszylinder	guide cylinder	cylindre de guidage
		X	155	N2640	1	O-Ring	o-ring	joint torique
			160	N2790	4	Stiftschraube	stud	goujon fileté
			165	N58	4	Scheibe	washer	rondelle



Wartungssätze
 Maintenance sets
 Kits d'entretien

Baugruppe Zylinder und Kolben, IK100
 Assembly Cylinders and pistons, IK100
 Assemblage Cylindres et pistons, IK100

A1.7- 2

Klasse/ Class/ Classe			Pos.	Bestell-Nr. Part No. No. de cde.	Anz. Qty. Qté.	Benennung	Designation	Dénomination
a	b	c						
		X	170	N370	4	Sechskantmutter	hexagon nut self-locking	écrou hexagonal auto-fr.
			180	072165	1	Kolben kpl.	piston cpl.	piston cpl.
			185	N484	2	Sicherungsring	circlip ring	rondelle de sûreté
X			190	078043	1	Kolbenbüchse kpl.	sleeve	douille
			195	N25376	1	Kolbenringsatz	Pistonring set	Jeu des segments
X			200	N23755	1	O-Ring	o-ring	joint torique
X			210	N4868	1	O-Ring	o-ring	joint torique

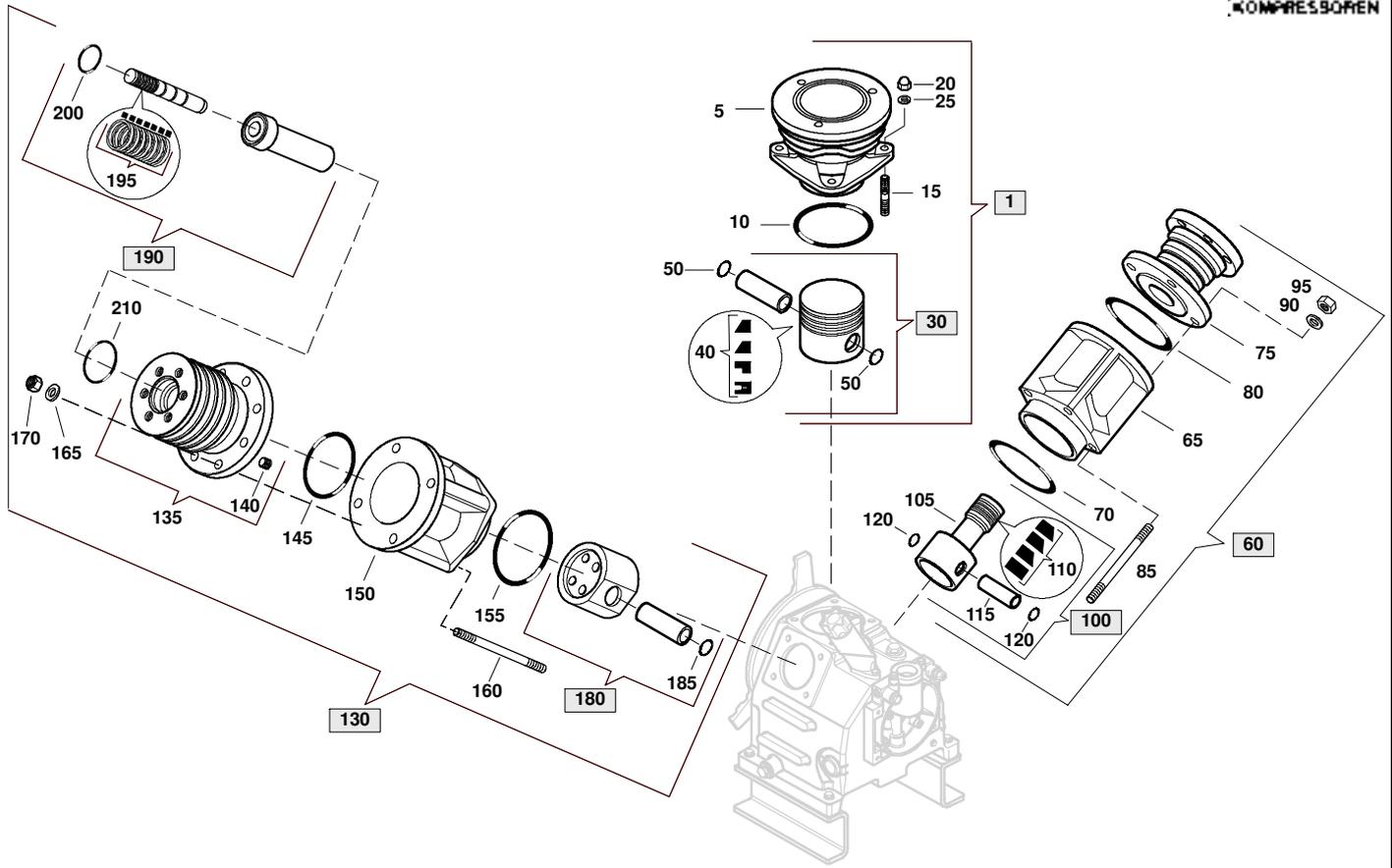



Wartungssätze
Maintenance sets
Kits d'entretien

Baugruppe Zylinder und Kolben, IK120
Assembly Cylinders and pistons, IK120
Assemblage Cylindres et pistons, IK120

A1.7- 3

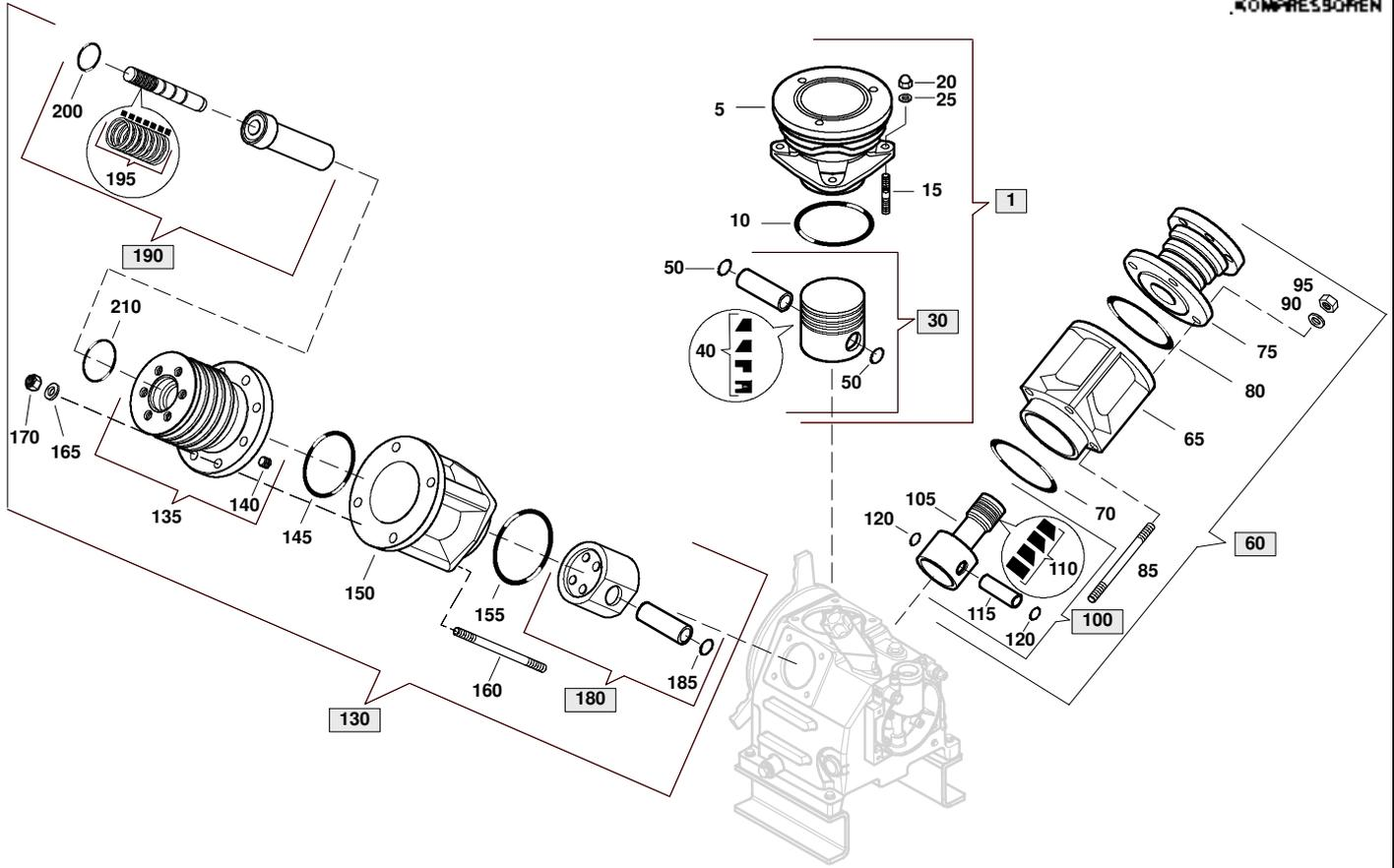
Klasse/ Class/ Classe			Pos.	Bestell-Nr. Part No. No. de cde.	Anz. Qty. Qté.	Benennung	Designation	Dénomination
a	b	c						
			1	80826	1	Zylinder kpl. 1.Stufe	cylinder assy. 1st stage	cylindre cpl. 1er étage
			5	80734	1	Zylinder	cylinder	cylindre
	X		10	N4654	1	O-Ring	o-ring	joint torique
			15	N215	4	Stiftschraube	stud	goujon fileté
	X		20	N370	4	Selbtsichernde Mutter	hexagon nut self-locking	écrou hexagonal auto-fr.
			25	N58	4	Scheibe	washer	rondelle
			30	069975	1	Kolben kpl.	piston cpl.	piston cpl.
			40	N1787	1	Kolbenringsatz	piston ring set	jeu des segments
			50	N484	2	Sicherungsring	circlip ring	rondelle de sûreté
			60	062899	1	Zylinder kpl. 2.Stufe	cylinder assy. 2nd stage	cylindre cpl. 2e étage
			65	83404	1	Führungszylinder	guide cylinder	cylindre guide
	X		70	N2640	1	O-Ring	o-ring	joint torique
			75	62477	1	Zylinder	cylinder	cylindre
	X		80	N7063	1	O-Ring	o-ring	joint torique
			85	N2790	4	Stiftschraube	stud	goujon fileté
			90	N58	4	Scheibe	washer	rondelle
	X		95	N370	4	Selbtsichernde Mutter	hexagon nut self-locking	écrou hexagonal auto-fr
			100	072249	1	Kolben kpl.	piston cpl.	piston cpl.
			105	62487	1	Kolben	piston	piston
			110	N2647	1	Kolbenringsatz	piston ring set	jeu de segments
			115	N1429	1	Kolbenbolzen	piston pin	axe de piston
			120	N484	2	Sicherungsring	circlip ring	rondelle de sûreté
			130	83400	1	Zylinder kpl. 3.Stufe	cylinder assy. 3rd stage	cylindre cpl. 3e étage
			135	82480	1	Zylinder	cylinder	cylindre
			140	N27318	1	Verschlußstopfen	screw	bouchon
	X		145	N7063	1	O-Ring	o-ring	joint torique
			150	83404	1	Führungszylinder	guide cylinder	cylindre de guidage
	X		155	N2640	1	O-Ring	o-ring	joint torique
			160	N2790	4	Stiftschraube	stud	goujon fileté
			165	N58	4	Scheibe	washer	rondelle



Wartungssätze
Maintenance sets
Kits d'entretien

Baugruppe Zylinder und Kolben, IK120
Assembly Cylinders and pistons, IK120
Assemblage Cylindres et pistons, IK120

A1.7- 3

Klasse/ Class/ Classe			Pos.	Bestell-Nr. Part No. No. de cde.	Anz. Qty. Qté.	Benennung	Designation	Dénomination
a	b	c						
		X	170	N370	4	Sechskantmutter	hexagon nut self-locking	écrou hexagonal auto-fr.
			180	072165	1	Kolben kpl.	piston cpl.	piston cpl.
			185	N484	2	Sicherungsring	circlip ring	rondelle de sûreté
X			190	078043	1	Kolbenbüchse kpl.	sleeve	douille
			195	N25376	1	Kolbenringsatz	Pistonring set	Jeu des segments
X			200	N23755	1	O-Ring	o-ring	joint torique
X			210	N4868	1	O-Ring	o-ring	joint torique

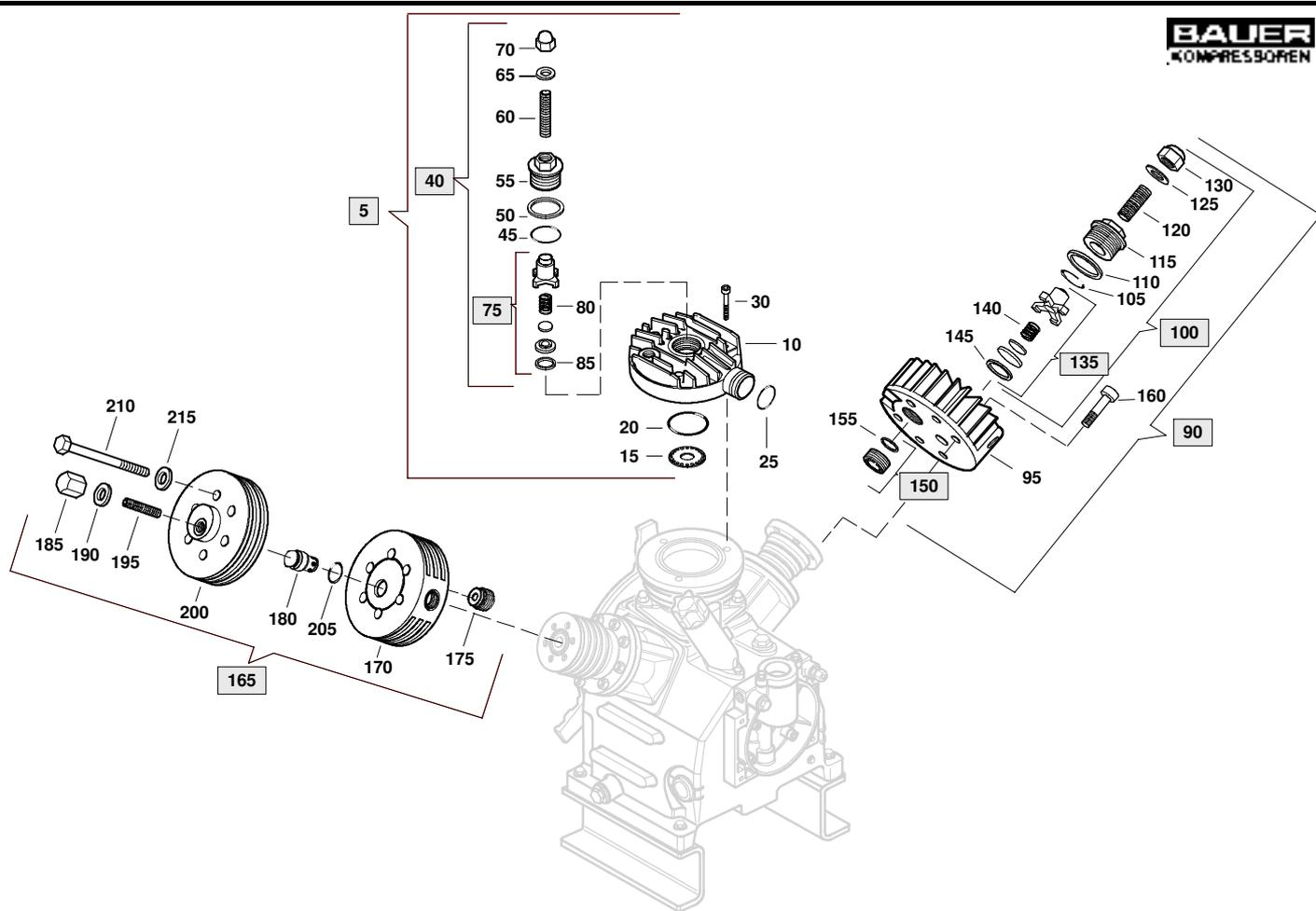

Wartungssätze
Maintenance sets
Kits d'entretien

Baugruppe Ventilköpfe, IK100
Assembly Valve heads, IK100
Assemblage Culasses, IK100

A1.7- 4

Klasse/ Class/ Classe			Pos.	Bestell-Nr. Part No. No. de cde.	Anz. Qty. Qté.	Benennung	Designation	Dénomination
a	b	c						
			5	069951	1	Ventilkopf 1. Stufe	valve head 1st stage	culasse 1er étage
			10	14907	1	Ventilkopf	valve head	culasse
	X		15	9884	1	Saugventilplatte	suction valve plate	clapet d'aspiration
X			20	N2169	1	O-Ring	o-ring	joint torique
			25	N1539	1	O-Ring	o-ring	joint torique
			30	N503	3	Zylinderschraube	allen screw	vis à six pans creux
			40	014583	1	Druckventil kpl.	pressure valve	soupape de compression
X			45	N3521	1	O-Ring	o-ring	joint torique
			50	14332	1	Tellerfeder	spring washer	rondelle-ressort
			55	14124	1	Verschraubung	coupling	raccord
	X		60	71064	1	Gewindestift	stud	goujon fileté
X			65	N380	1	Dichtung	gasket	joint
			70	N84	1	Sechskant-Hutmutter	acorn nut	écrou borgne
	X		75	012840	1	Druckventileinsatz kpl.	pressure valve insert	soupape de pression
			80	1026	1	Ventilfeder	valve spring	ressort de soupape
X			85	240	1	Dichtung	gasket	joint
			90	069955	1	Ventilkopf 2. Stufe	valve head 2nd stage	culasse 2e étage
			95	14123	1	Ventilkopf	valve head	culasse
			100	014582	1	Druckventil kpl.	discharge valve assy.	soupape de pression
X			105	N3521	1	O-Ring	o-ring	joint torique
			110	14332	1	Tellerfeder	spring washer	rondelle-ressort
			115	14124	1	Verschraubung	coupling	raccord
	X		120	71064	1	Gewindestift	stud	goujon fileté
X			125	N3625	1	Dichtung	gasket	joint
			130	N84	1	Sechskant-Hutmutter	acorn nut	écrou borgne
	X		135	012835	1	Druckventileinsatz kpl.	discharge valve insert	soupape de pression
			140	1026	1	Ventilfeder	valve spring	ressort de soupape
X			145	240	1	Dichtung	gasket	joint
X	X		150	012841	1	Saugventil	intake valve	soupape d'aspiration
X			155	240	1	Dichtung	gasket	joint

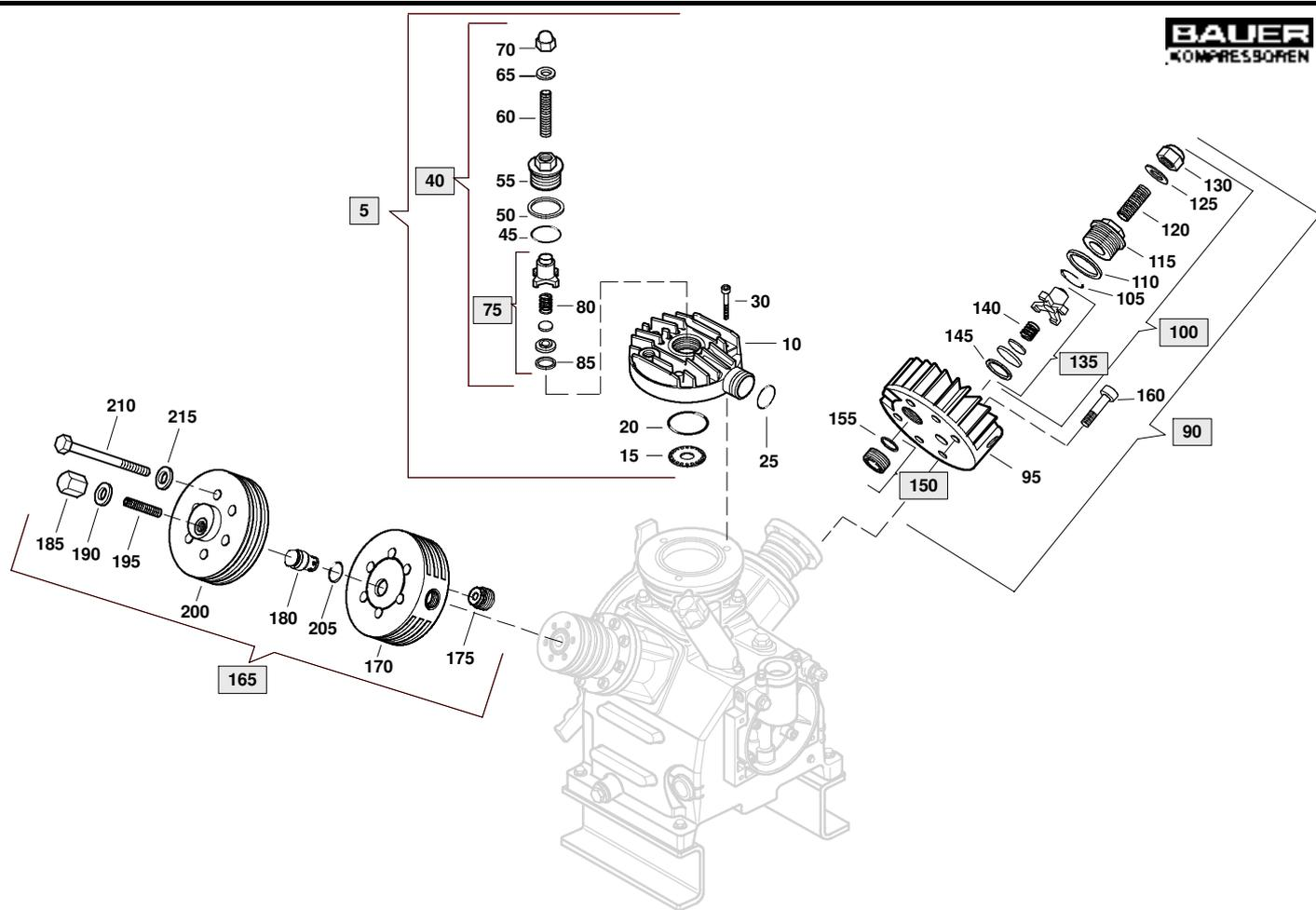



Wartungssätze
Maintenance sets
Kits d'entretien

Baugruppe Ventilköpfe, IK100
Assembly Valve heads, IK100
Assemblage Culasses, IK100

A1.7- 4

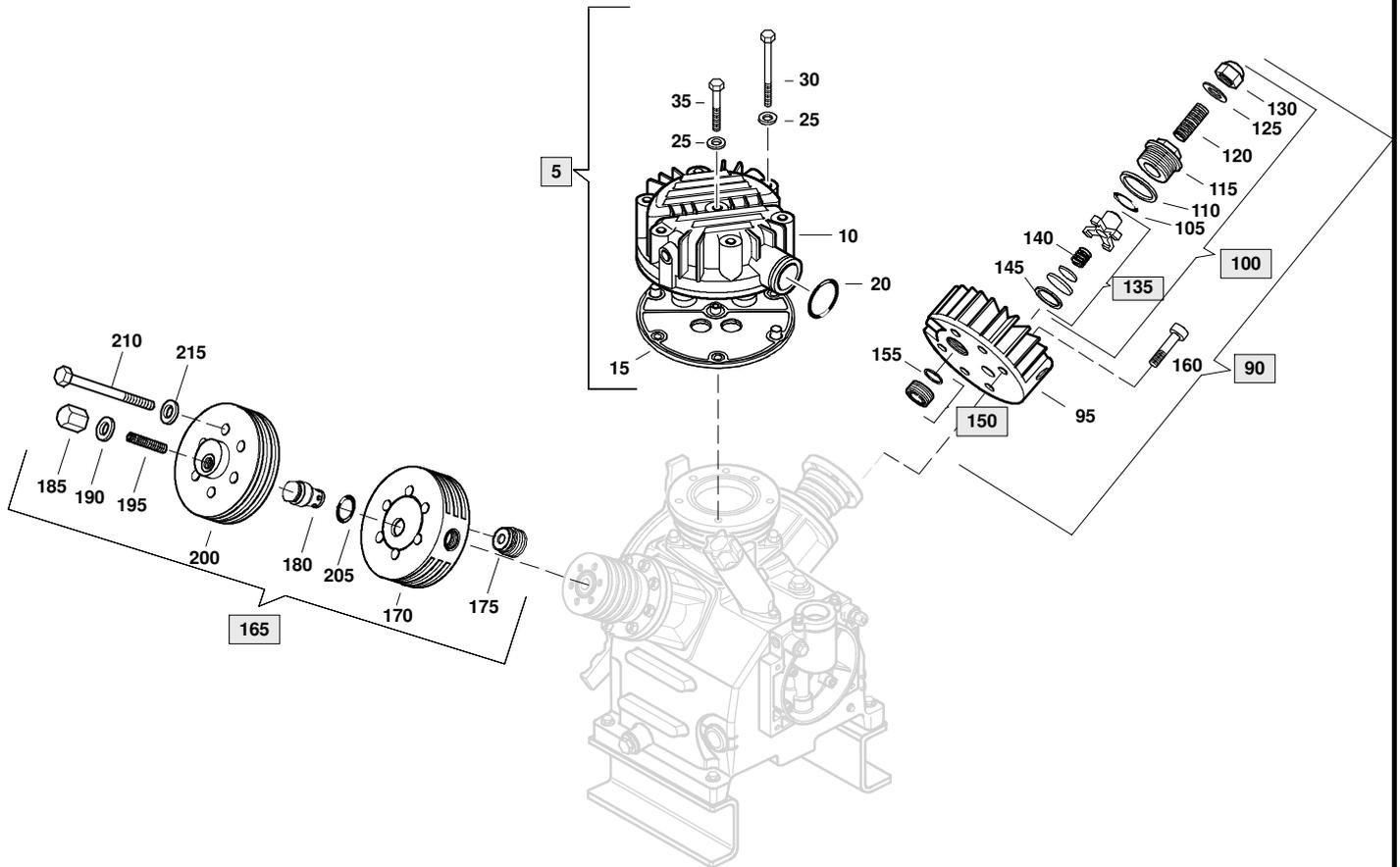
Klasse/ Class/ Classe			Pos.	Bestell-Nr. Part No. No. de cde.	Anz. Qty. Qté.	Benennung	Designation	Dénomination
a	b	c						
			160	N503	6	Zylinderschraube	allen screw	vis à six pans creux
			165	82096	1	Ventilkopf 3. Stufe	valve head 3rd stage	culasse 3e étage
			170	82087	1	Ventilkopf	valve head	culasse
	X		175	81409	1	Saugventil	suction valve	clapet d'aspiration
	X		180	014121	1	Druckventil	pressure valve	soupape de pression
			185	N3589	1	Sechskant-Hutmutter	acorn nut	écrou borgne
X			190	N3625	1	Dichtring	gasket	joint
	X		195	N3738	1	Gewindestift	stud	goujon fileté
			200	82086	1	Ventilkopf-Deckel	valve head cover	couvercle de culasse
			205	N2789	1	O-Ring	o-ring	joint torique
			210	N17730	6	Zylinderschraube	allen screw	vis à six pans creux
			215	N58	6	Scheibe	washer	rondelle



Wartungssätze
 Maintenance sets
 Kits d'entretien

Baugruppe Ventilköpfe, IK120
 Assembly Valve heads, IK120
 Assemblage Culasses, IK120

A1.7- 5

Klasse/ Class/ Classe			Pos.	Bestell-Nr. Part No. No. de cde.	Anz. Qty. Qté.	Benennung	Designation	Dénomination
a	b	c						
			5	80688	1	Ventilkopf 1. Stufe	valve head 1st stage	culasse 1er étage
			10	80677	1	Ventilkopf	valve head	culasse
			15	N26531	1	Lamellenventil	reed valve	soupage à lamelles
			20	N1539	1	O-Ring	o-ring	joint torique
			25	N102	1	Scheibe	washer	rondelle
			30	N26568	6	Sechskantschraube	hex. screw	vis six pans
			35	N26646	1	Sechskantschraube	hex. screw	vis six pans
			90	069955	1	Ventilkopf 2. Stufe	valve head 2nd stage	culasse 2e étage
			95	14123	1	Ventilkopf	valve head	culasse
			100	014582	1	Druckventil kpl.	discharge valve assy.	soupage de pression
X			105	N3521	1	O-Ring	o-ring	joint torique
			110	14332	1	Tellerfeder	spring washer	rondelle-ressort
			115	14124	1	Verschraubung	coupling	raccord
	X		120	71064	1	Gewindestift	stud	goujon fileté
X			125	N3625	1	Dichtung	gasket	joint
			130	N84	1	Sechskant-Hutmutter	acorn nut	écrou borgne
	X		135	012835	1	Druckventileinsatz kpl.	discharge valve insert	soupage de pression
			140	1026	1	Ventilfeder	valve spring	ressort de soupage
X			145	240	1	Dichtung	gasket	joint
	X		150	012841	1	Saugventil	intake valve	soupage d'aspiration
X			155	240	1	Dichtung	gasket	joint
			160	N503	6	Zylinderschraube	allen screw	vis à six pans creux
			165	82096	1	Ventilkopf 3. Stufe	valve head 3rd stage	culasse 3e étage
			170	82087	1	Ventilkopf	valve head	culasse
	X		175	81409	1	Saugventil	suction valve	clapet d'aspiration
	X		180	014121	1	Druckventil	pressure valve	soupage de pression
			185	N3589	1	Sechskant-Hutmutter	acorn nut	écrou borgne
X			190	N3625	1	Dichtring	gasket	joint
	X		195	N3738	1	Gewindestift	stud	goujon fileté
			200	82086	1	Ventilkopf-Deckel	valve head cover	couvercle de culasse

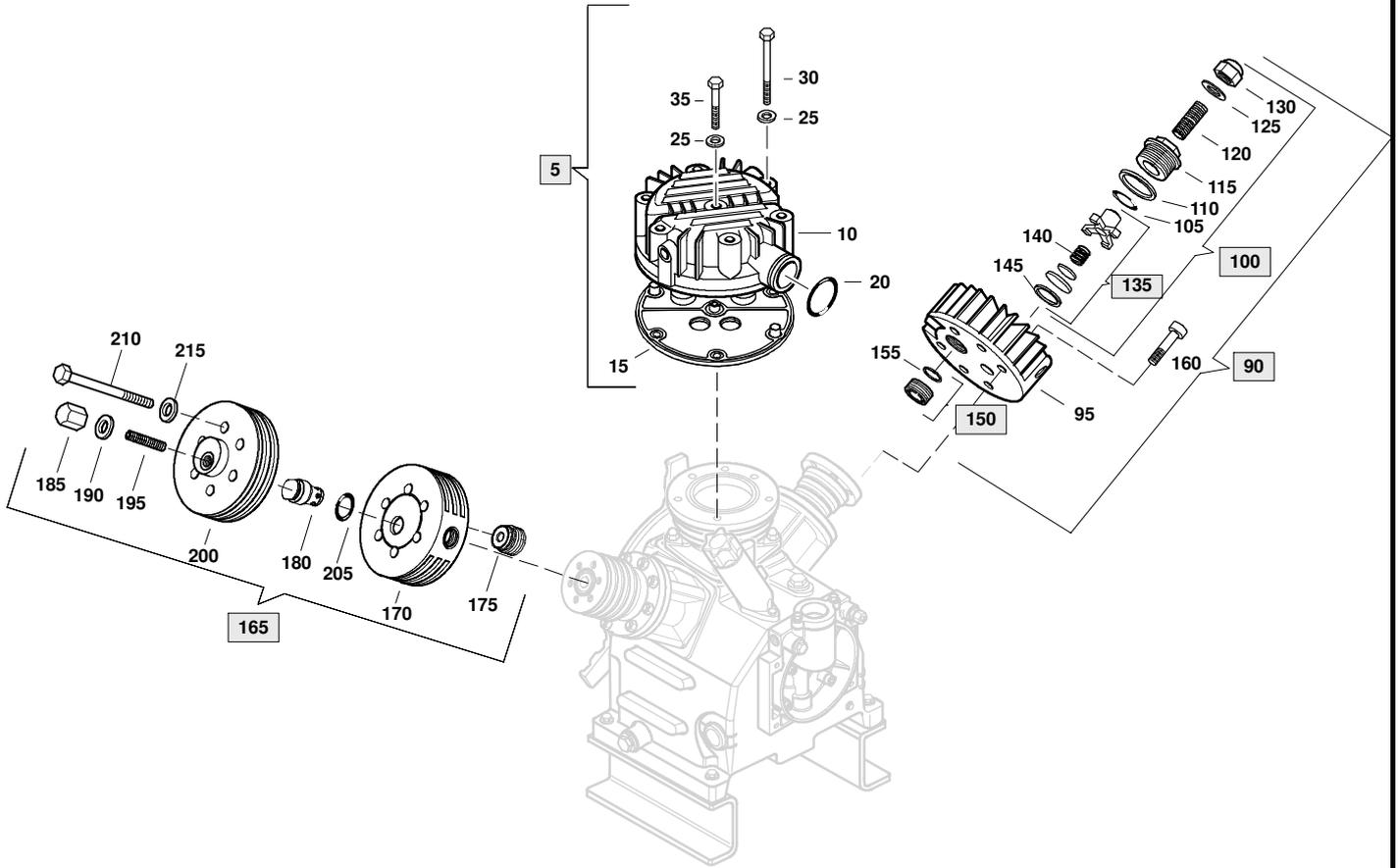

Wartungssätze
Maintenance sets
Kits d'entretien

Baugruppe Ventilköpfe, IK120
Assembly Valve heads, IK120
Assemblage Culasses, IK120

A1.7- 5

Klasse/ Class/ Classe			Pos.	Bestell-Nr. Part No. No. de cde.	Anz. Qty. Qté.	Benennung	Designation	Dénomination
a	b	c						
			205	N2789	1	O-Ring	o-ring	joint torique
			210	N17730	6	Zylinderschraube	allen screw	vis à six pans creux
			215	N58	6	Scheibe	washer	rondelle

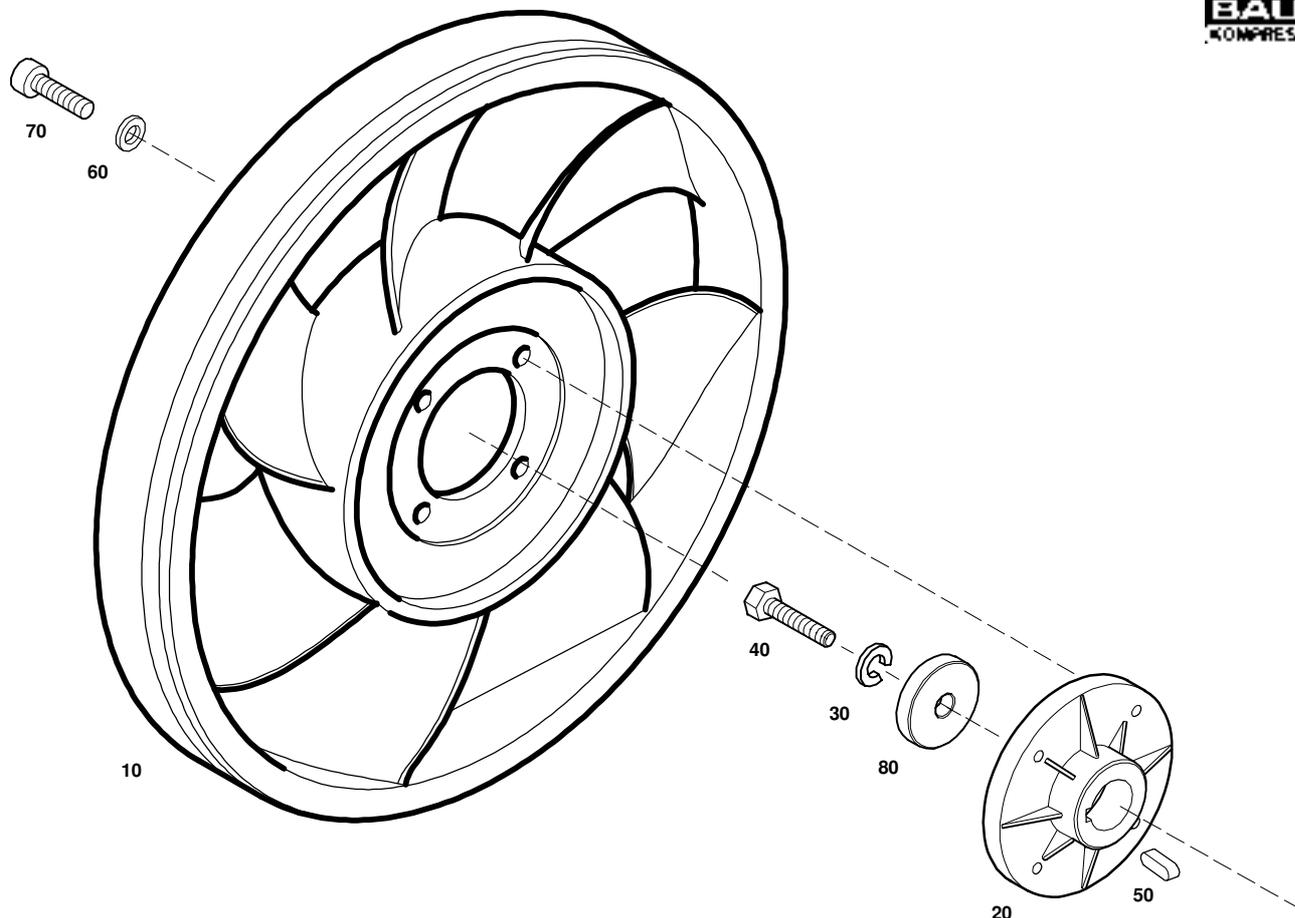

Wartungssätze
 Maintenance sets
 Kits d'entretien

Baugruppe 82552 Schwungrad
 Assembly 82552 Flywheel
 Assemblage 82552 Volant-ventilateur

A1.7- 6

Klasse/ Class/ Classe			Pos.	Bestell-Nr. Part No. No. de cde.	Anz. Qty. Qté.	Benennung	Designation	Dénomination
a	b	c						
			10	82496	1	Ventilatorrad	fanwheel	ventilateur
			20	82553	1	Ventilatorradnabe	fanwheel hub	moyeu de ventilateur
			30	N176	1	Federscheibe	spring washer	rondelle de sûreté
			40	N26666	4	Schraube	screw	vis à six pans
			50	N1386	1	Paßfeder	feather key	ressort d'ajustage
			60	N108	4	Federscheibe	spring washer	rondelle de sûreté
			70	N19548	4	Zylinderschraube	allen screw	vis allen
			80	80975	1	Scheibe	washer	rondelle

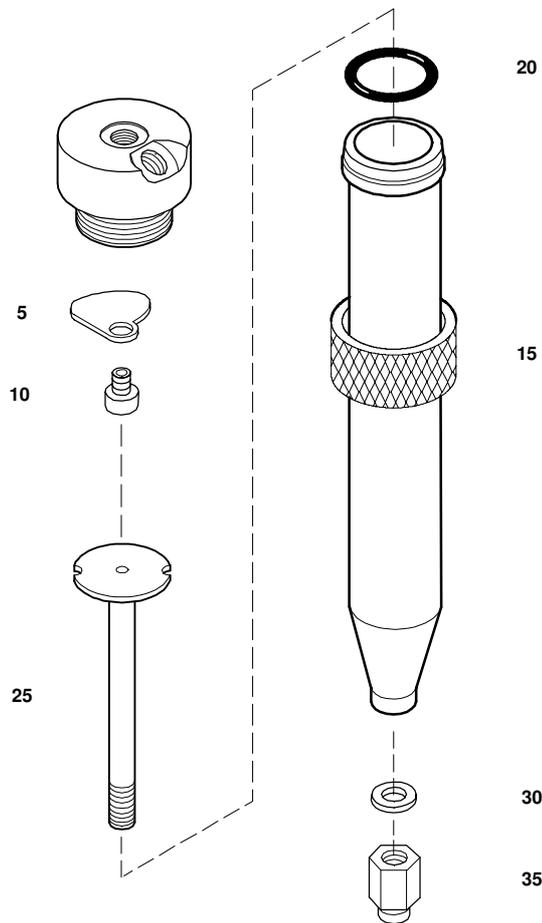

Wartungssätze
Maintenance sets
Kits d'entretien

Baugruppe 81799 Zwischenfilter
Assembly 81799 Inter filter
Assemblage 81799 Filtre intermédiaire

A1.7- 7

Klasse/ Class/ Classe			Pos.	Bestell-Nr. Part No. No. de cde.	Anz/ Qty/ Qté	Benennung	Designation	Dénomination
a	b	c						
			5	81148	1	Blech	plate	plaque
			10	81643	1	Hohlschraube	hollow screw	vis creuse
			15	13937	1	Überwurfmutter	screw cap	écrou borgne
X			20	N3556	1	O-Ring	o-ring	joint torique
			25	76613	1	Einschraubteil kpl.	insert assy.	pièce à visser cpl.
			30	N1316	1	Dichtung	gasket	joint
			35	N20215	1	Ger. Aufschraubst.	male fitting	manchon mâle

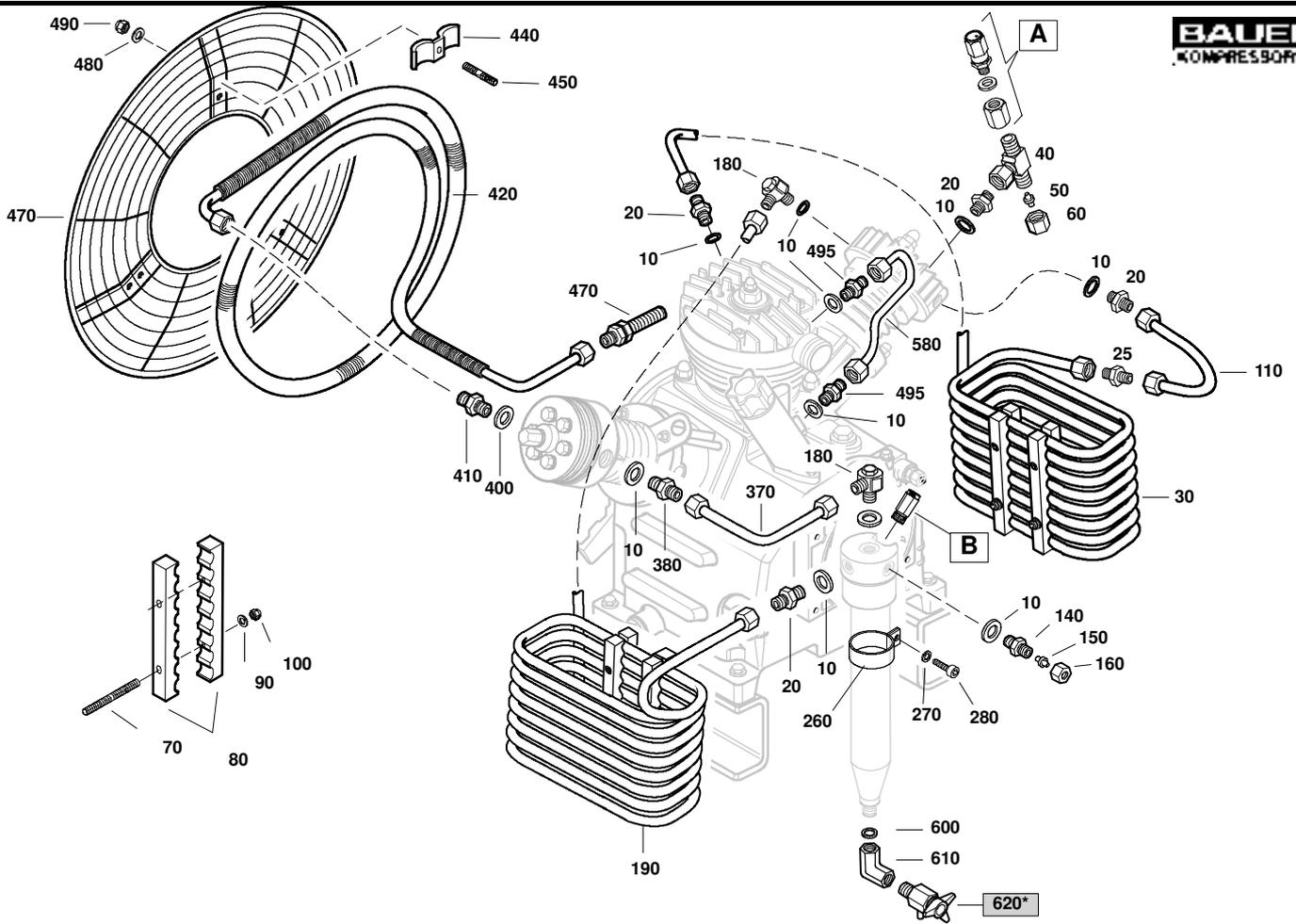

Wartungssätze
Maintenance sets
Kits d'entretien

Baugruppe 83453 **Kühlung IK100**
Assembly 83453 **Cooling system IK100**
Assemblage 83453 **Refroidissement IK100**

A1.7- 8

Klasse/ Class/ Classe			Pos.	Bestell-Nr. Part No. No. de cde.	Anz. Qty. Qté.	Benennung	Designation	Dénomination
a	b	c						
			A	81802	1	Sicherheitsventil 9 bar	safety valve 9 bar	Soupape de sûreté 9 bar
			B	072935	1	Sicherheitsventil 60 bar	safety valve 60 bar	Soupape de sûreté 60 bar
			10	N1316	8	Dichtring	gasket	joint
			20	N20059	3	G-Einschraubstutzen	fitting	raccord droit mâle
			25	N20310	1	G-Stutzen	coupling	raccord
			30	79486	1	Zwischenkühler kpl.	intermediate cooler cpl.	refroidisseur interméd.
			40	N20327	1	T-Stutzen	T connector	raccord T
			50	N15175	1	Verschlußstopfen	plug	bouchon
			60	N7433	1	Überwurfmutter	screw cap 6S	écrou borgne
			70	N3494	4	Stiftschraube	stud	goujon fileté
			80	62773	4	Fixierung	fixing for cooler	fixation de refroidisseur
			90	N102	4	Scheibe	washer	rondelle
			100	N1042	4	Sechskantmutter	hexagon nut self-locking	écrou hexagonal auto-fr
			110	81297	1	Verbindungsleitung kpl.	connecting tube assy.	conduite de liaison cpl.
			140	N20195	1	G-Einschraubstutzen	male connector	raccord droit mâle
			150	N4530	1	Verschlußstopfen	plug	bouchon
			160	N3610	1	Überwurfmutter	screw cap 6S	écrou borgne
			180	N26751	2	Schwenkstutzen	coupling	raccord
			190	78195	1	Zwischenkühler kpl.	intercooler	refroidisseur interméd.
			260	77894	2	Rohrschelle	clamp	collier
			270	N2460	2	Scheibe	washer	rondelle
			280	N88	2	Sechskantschraube	hexagon screw	vis hexagonale
			290	N1316	1	Dichtring	gasket	joint
			300	N52	1	Verschlußschraube	plug	bouchon fileté
			320	N20195	1	G-Einschraubstutzen	male connector	raccord droit mâle
			330	N4530	1	Verschlußstopfen	plug	bouchon
			340	N3610	1	Überwurfmutter	screw cap 6S	écrou borgne
			370	78197	1	Verbindungsleitung kpl.	connecting tube assy.	conduite de liaison cpl.
			380	N20195	1	G-Einschraubstutzen	male connector	raccord droit mâle
			400	56983	1	Dichtring	gasket	joint

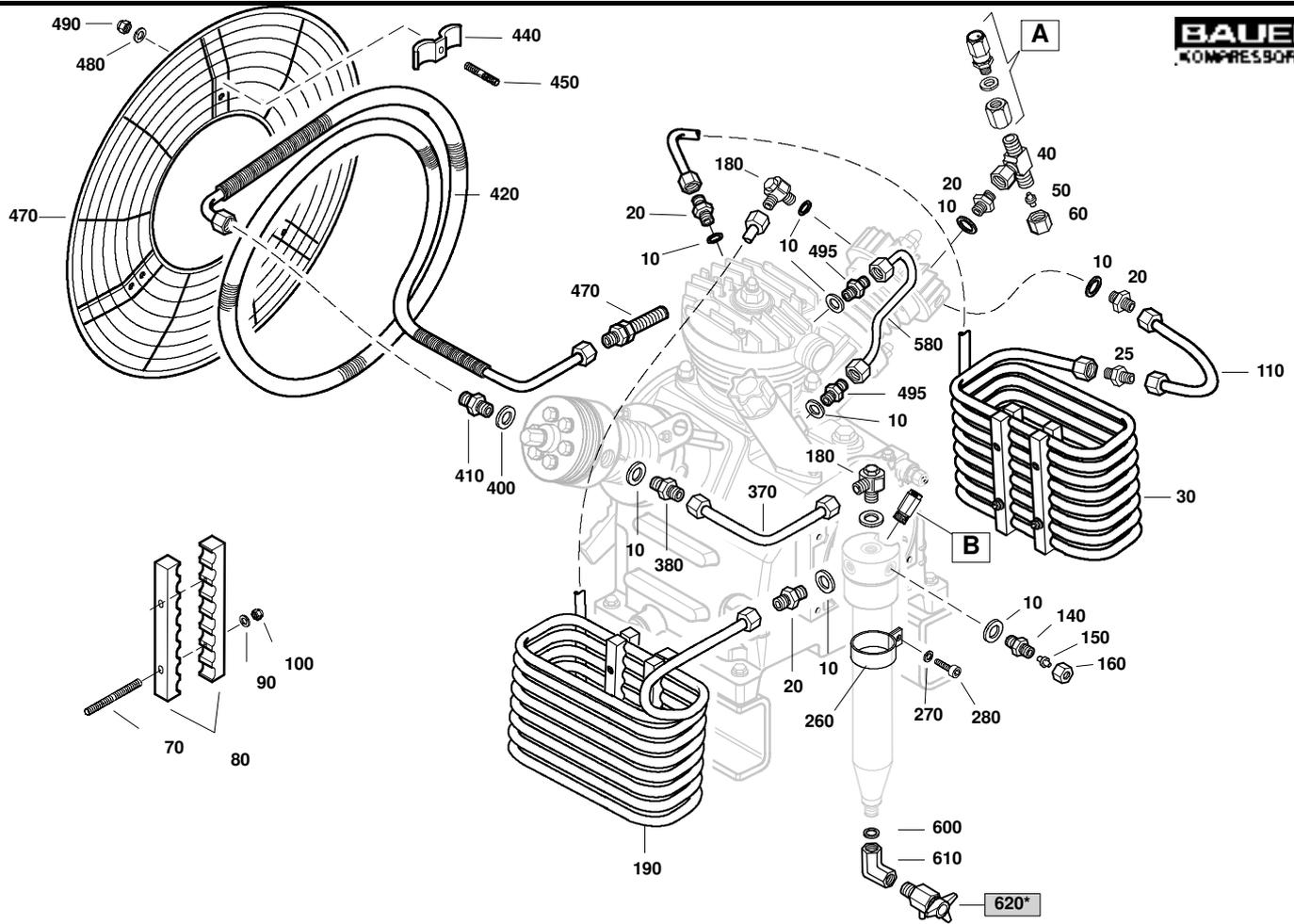

Wartungssätze
Maintenance sets
Kits d'entretien

Baugruppe 83453 **Kühlung IK100**
Assembly 83453 **Cooling system IK100**
Assemblage 83453 **Refroidissement IK100**

A1.7- 8

Klasse/ Class/ Classe			Pos.	Bestell-Nr. Part No. No. de cde.	Anz. Qty. Qté.	Benennung	Designation	Dénomination
a	b	c						
			410	71148	1	Rohrverschraubung	connector	raccord
			420	070724	1	Nachkühler kpl.	after cooler cpl.	refroidisseur final cpl.
			440	11887	3	Schelle	double strap	collier double
			450	78199	3	Gewindestift	headless screw	vis sans tête
			460	N20183	1	G-Schottstutzen	connector	raccord
			470	78200	1	Lüfterradschutz	flywheel protector	protection du ventilateur
			480	N58	3	Scheibe	washer	rondelle
			490	N370	3	Sechskantmutter	hexagon nut self-locking	écrou hexagonal auto-fr
			495	N20014	2	G-Einschraubstutzen	fitting	raccord
			500	82496	1	Ventilatorrad	fanwheel	ventilateur
			510	82553	1	Ventilatorradnabe	fanwheel hub	moyeu de ventilateur
			520	N176	1	Federscheibe	spring washer	rondelle de sûreté
			530	N26666	4	Schraube	screw	vis à six pans
			540	N1386	1	Paßfeder	feather key	ressort d'ajustage
			550	N108	4	Federscheibe	spring washer	rondelle de sûreté
			560	N19548	4	Zylinderschraube	allen screw	vis allen
			570	80975	1	Scheibe	washer	rondelle
			580	73583	1	Verbindungsleitung kpl.	connecting tube assy.	conduite de liaison cpl.
			600	N1316	1	Dichtung	gasket	joint
			610	N26972	1	W-Verschraubung	elbow coupling	coude
			620	011430*	1	Ablaßhahn kpl.	drain valve	vanne de purge cpl.

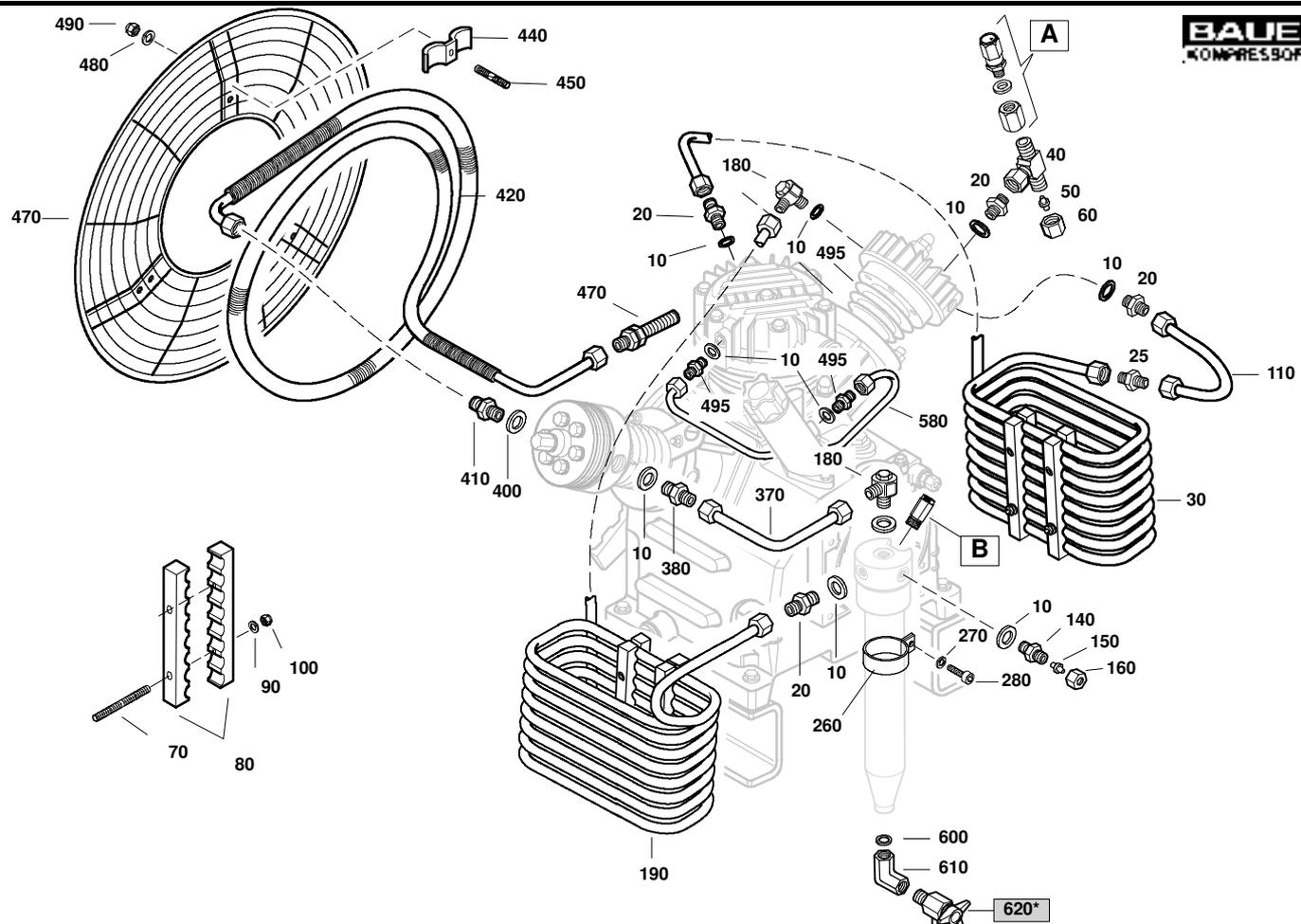

Wartungssätze
Maintenance sets
Kits d'entretien

Baugruppe 83456 **Kühlung, IK120**
Assembly 83456 **Cooling system, IK120**
Assemblage 83456 **Refroidissement, IK120**

A1.7- 9

Klasse/ Class/ Classe			Pos.	Bestell-Nr. Part No. No. de cde.	Anz. Qty. Qté.	Benennung	Designation	Dénomination
a	b	c						
			A	81802	1	Sicherheitsventil 9 bar	safety valve 9 bar	Soupape de sûreté 9 bar
			B	072935	1	Sicherheitsventil 60 bar	safety valve 60 bar	Soupape de sûreté 60 bar
			10	N1316	8	Dichtring	gasket	joint
			20	N20059	3	G-Einschraubstutzen	fitting	raccord droit mâle
			25	N20310	1	G-Stutzen	coupling	raccord
			30	79486	1	Zwischenkühler kpl.	intermediate cooler cpl.	refroidisseur interméd.
			40	N20327	1	T-Stutzen	T connector	raccord T
			50	N15175	1	Verschlußstopfen	plug	bouchon
			60	N7433	1	Überwurfmutter	screw cap 6S	écrou borgne
			70	N3494	4	Stiftschraube	stud	goujon fileté
			80	62773	4	Fixierung	fixing for cooler	fixation de refroidisseur
			90	N102	4	Scheibe	washer	rondelle
			100	N1042	4	Sechskantmutter	hexagon nut self-locking	écrou hexagonal auto-fr
			110	81297	1	Verbindungsleitung kpl.	connecting tube assy.	conduite de liaison cpl.
			140	N20195	1	G-Einschraubstutzen	male connector	raccord droit mâle
			150	N4530	1	Verschlußstopfen	plug	bouchon
			160	N3610	1	Überwurfmutter	screw cap 6S	écrou borgne
			180	N26751	2	Schwenkstutzen	coupling	raccord
			190	78195	1	Zwischenkühler kpl.	intercooler	refroidisseur interméd.
			260	77894	2	Rohrschelle	clamp	collier
			270	N2460	2	Scheibe	washer	rondelle
			280	N88	2	Sechskantschraube	hexagon screw	vis hexagonale
			290	N1316	1	Dichtring	gasket	joint
			300	N52	1	Verschlußschraube	plug	bouchon fileté
			320	N20195	1	G-Einschraubstutzen	male connector	raccord droit mâle
			330	N4530	1	Verschlußstopfen	plug	bouchon
			340	N3610	1	Überwurfmutter	screw cap 6S	écrou borgne
			370	78197	1	Verbindungsleitung kpl.	connecting tube assy.	conduite de liaison cpl.
			380	N20195	1	G-Einschraubstutzen	male connector	raccord droit mâle
			400	56983	1	Dichtring	gasket	joint

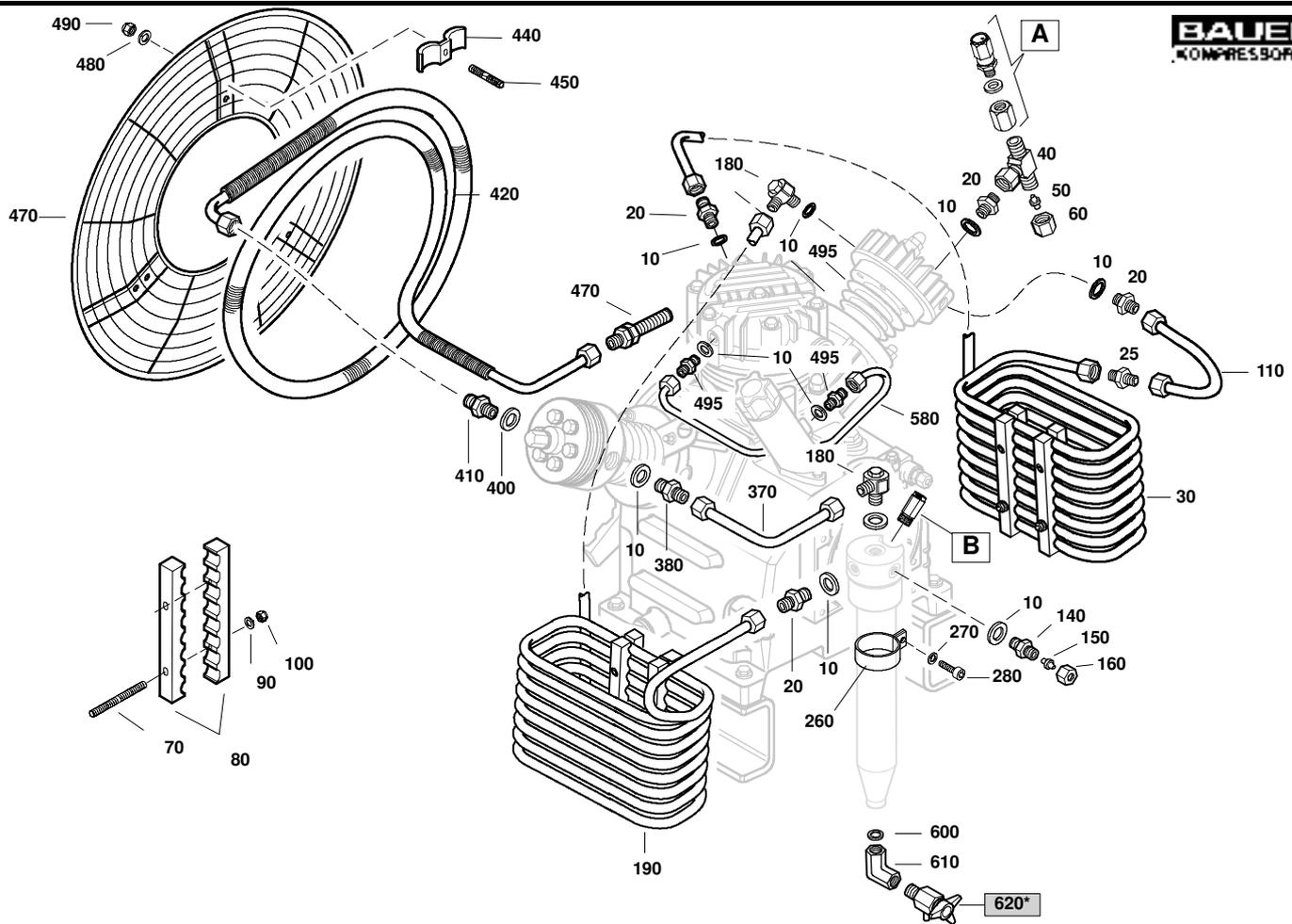

Wartungssätze
 Maintenance sets
 Kits d'entretien

Baugruppe 83456 Kühlung, IK120
 Assembly 83456 Cooling system, IK120
 Assemblage 83456 Refroidissement, IK120

A1.7- 9

Klasse/ Class/ Classe			Pos.	Bestell-Nr. Part No. No. de cde.	Anz. Qty. Qté.	Benennung	Designation	Dénomination
a	b	c						
			410	71148	1	Rohrverschraubung	connector	raccord
			420	070724	1	Nachkühler kpl.	after cooler cpl.	refroidisseur final cpl.
			440	11887	3	Schelle	double strap	collier double
			450	78199	3	Gewindestift	headless screw	vis sans tête
			460	N20183	1	G-Schottstutzen	connector	raccord
			470	78200	1	Lüfterradschutz	flywheel protector	protection du ventilateur
			480	N58	3	Scheibe	washer	rondelle
			490	N370	3	Sechskantmutter	hexagon nut self-locking	écrou hexagonal auto-fr
			495	N20014	2	G-Einschraubstutzen	fitting	raccord
			500	82496	1	Ventilatorrad	fanwheel	ventilateur
			510	82553	1	Ventilatorradnabe	fanwheel hub	moyeu de ventilateur
			520	N176	1	Federscheibe	spring washer	rondelle de sûreté
			530	N26666	4	Schraube	screw	vis à six pans
			540	N1386	1	Paßfeder	feather key	ressort d'ajustage
			550	N108	4	Federscheibe	spring washer	rondelle de sûreté
			560	N19548	4	Zylinderschraube	allen screw	vis allen
			570	80975	1	Scheibe	washer	rondelle
			580	81389	1	Verbindungsleitung kpl.	connecting tube assy.	conduite de liaison cpl.
			600	N1316	1	Dichtung	gasket	joint
			610	N26972	1	W-Verschraubung	elbow coupling	coude
			620	011430*	1	Ablaßhahn kpl.	drain valve	vanne de purge cpl.

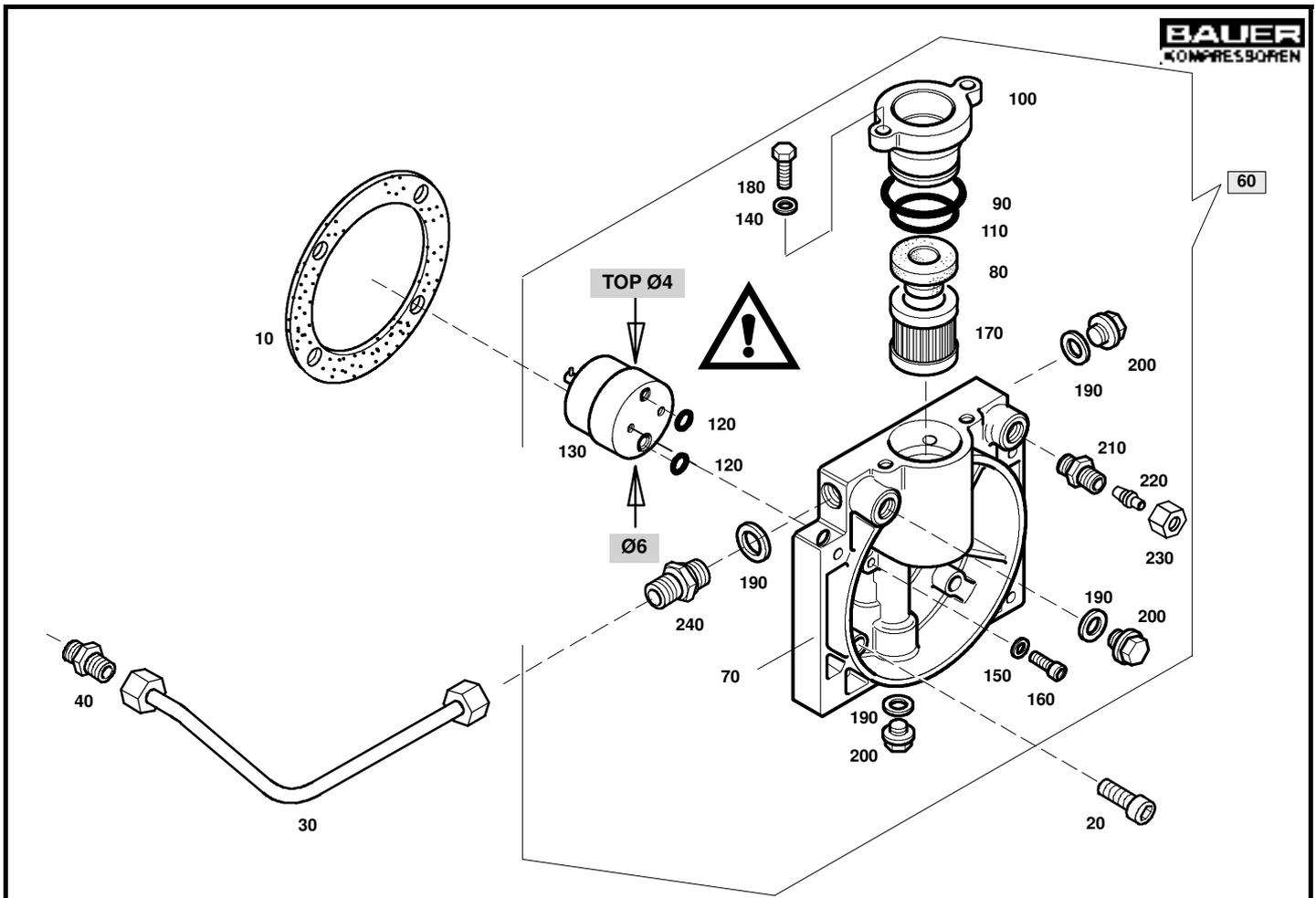

Wartungssätze
 Maintenance sets
 Kits d'entretien

Baugruppe 83417
 Assembly 83417
 Assemblage 83417

Druckölschmierung kpl.
 Lubricating system assy.
 Lubrification cpl.

A1.7- 10

Klasse/ Class/ Classe			Pos	Bestell-Nr. Part No. No. de cde.	Anz Qty. Qté.	Benennung	Designation	Dénomination
a	b	c						
			10	78421	1	Dichtung	gasket	joint
			20	N123	4	Zylinderschraube	allen screw	vis allen
			30	83420	1	Verbindungsleitung kpl.	connecting tube assy.	conduite cpl.
			40	N20237	1	G-Einschraubstutzen	straight coupling	raccord mâle droit
			60	81075	1	Druckölschmierung	lubricating system	système de lubrification
			70	77878	1	Deckel	cover plate	couvercle
			80	77774	1	Dichtung	gasket	joint
			90	N4058	1	O-Ring	o-ring	joint torique
			100	77885	1	Deckel	für Ölfilter	Deckel
			110	N25327	1	O-Ring	o-ring	joint torique
			120	N3489	2	O-Ring	o-ring	joint torique
			130	N24585	1	Zahnradpumpe	pump	pompe
			140	N58	2	Scheibe	washer	rondelle
			150	N2889	2	Dichtring	gasket	joint
			160	N25328	2	Zylinderschraube	allen screw	vis allen
			170	N25326	1	Filterelement	filter insert	élément filtrant
			180	N19506	2	Sechskantschraube	hex. screw	vis à six pans
			190	N1316	4	Dichtring	gasket	joint
			200	N52	3	Verschlussschraube	plug screw	bouchon
			210	N20065	1	G-Einschraubstutzen	coupling	raccord
			220	N16309	1	Verschlussstopfen	plug	bouchon
			230	N1049	1	Überwurfmutter	screw cap	écrou chapeau
			240	81050	1	Reguliventil	regulator valve	soupape de régulation

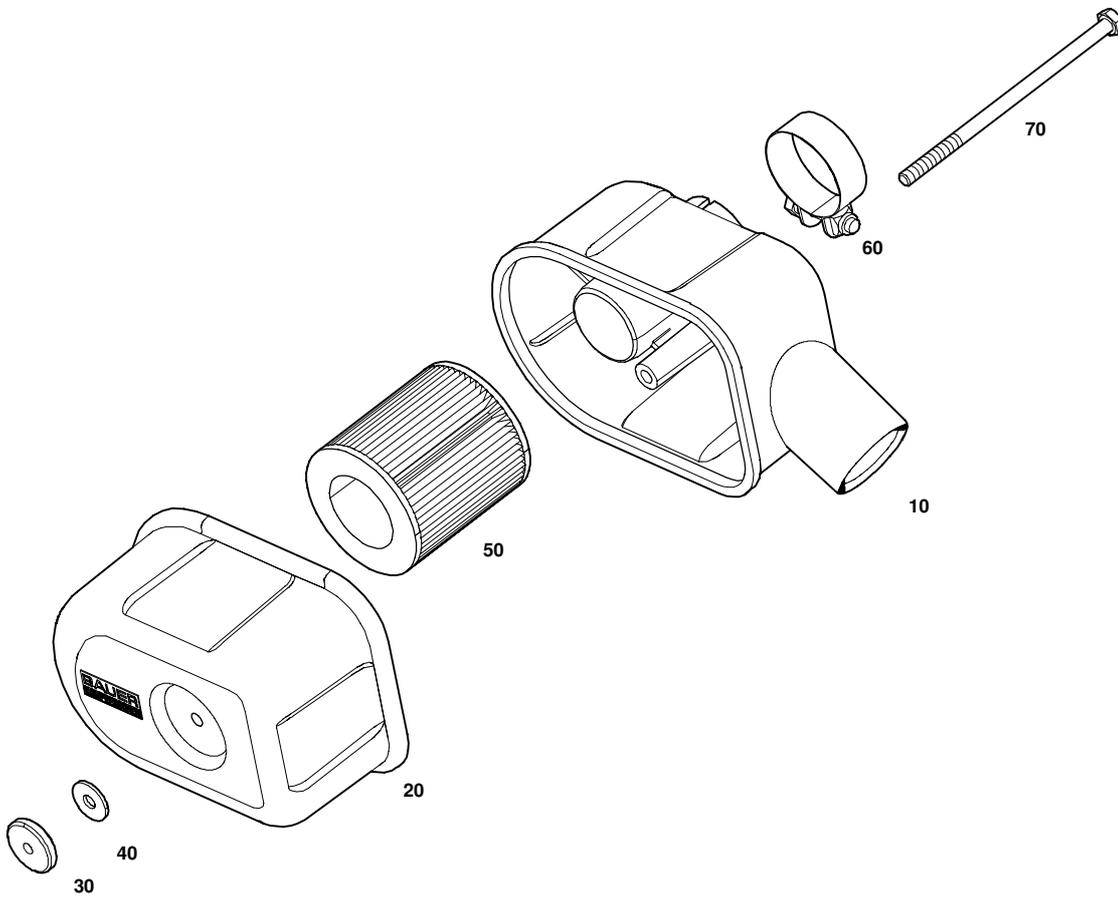

Ersatzteilsätze
Spare parts sets
Kits de pièces
dét.

Baugruppe 79577 Ansaugfilter
Assembly 79577 Intake filter
Assemblage 79577 Filtre d'aspiration

A1.7- 11

Klasse/ Class/ Classe			Pos.	Bestell-Nr. Part No. No. de cde.	Anz. Qty. Qté.	Benennung	Designation	Dénomination
a	b	c						
			10	79575	1	Ansaugfilter-Gehäuse	intake filter housing	boîtier de filtre
			20	79574	1	Ansaugfilter-Deckel	suction filter cover	couvercle de filtre
			30	N4870	1	Rändelmutter	nut	écrou
			40	N3313	1	Scheibe	washer	rondelle
X			50	N25950	1	Filtereinsatz	filter insert	élément filtrant
			60	N3374	1	Schelle	clamp	collier
			70	N19502	1	Sechskantschraube	hex. screw	vis 6 pans

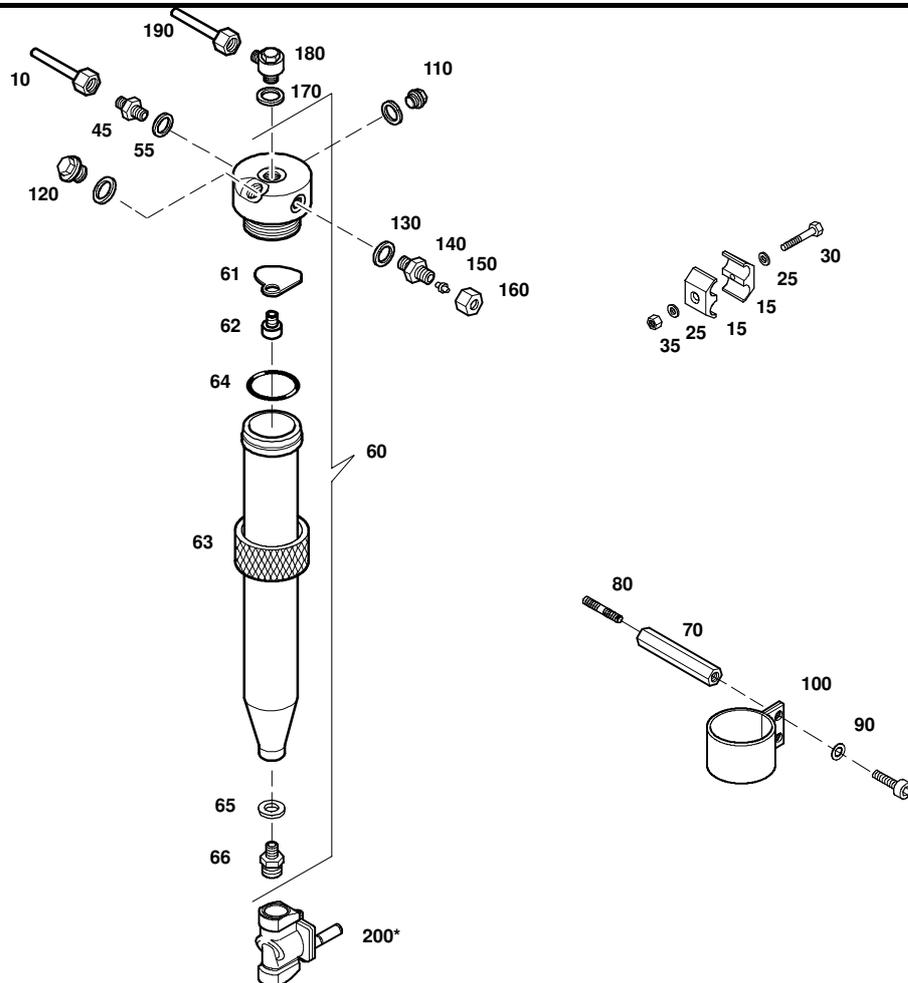

Wartungssätze
Maintenance sets
Kits d'entretien

Baugruppe 82175 **Zwischenfilter, 1 St.**
Assembly 82175 **Intermediate separator, 1st stage**
Assemblage 82175 **Séparateur intermédiaire, 1er étage**

A1.7- 12

Klasse/ Class/ Classe			Pos.	Bestell-Nr. Part No. No. de cde.	Anz. Qty. Qté.	Benennung	Designation	Dénomination
a	b	c						
			10	82180	1	Verbindungsleitung	connecting tube	tuyau de connexion
			15	55698-M	2	Fixierung	fixing for cooler	fixation de refroidisseur
			25	N102	2	Scheibe	washer	rondelle
			30	N3498	1	Sechskantschraube	hexagon screw	vis hexagonale
			35	N1042	1	Sechskantmutter	hexagon nut self-locking	écrou hexagonal auto-frein.
			45	N20059	1	G-Einschraubstutzen	straight male connector	raccord droit mâle
X			55	N1316	1	Dichtring	gasket	joint
			60	81106	2	Zwischenfilter	separator	séparateur
			61	81148	1	Blech	plate	plaque
			62	81643	1	Hohlschraube	hollow screw	vis creuse
			63	13937	1	Überwurfmutter	screw cap	écrou borgne
X			64	N3556	1	O-Ring	o-ring	joint torique
			65	N1316	1	Dichtung	gasket	joint
			66	N20059	1	G-Einschraubstutzen	straight male connector	raccord droit mâle
			70	69046	2	Sechskant	hex. stud	entretoise six pans
			80	N215	2	Stiftschraube	stud	goujon fileté
			90	N2460	2	Scheibe	washer	rondelle
			100	77894	2	Rohrschelle	clamp	collier
			110	N4570	2	Verschlußschraube	plug	bouchon fileté
			120	N204	1	Verschlußschraube	plug	bouchon fileté
X			130	4479	1	Dichtring	gasket	joint
			140	N20195	1	G-Einschraubstutzen	straight male connector	raccord droit mâle
			150	N4530	1	Verschlußstopfen	plug	bouchon
			160	N3610	1	Überwurfmutter	screw cap	écrou chapeau
			170	N1316	1	Dichtung	gasket	joint
			180	N26751	1	Schwenkstutzen	connector	raccord
			190	79062	1	Verbindungsleitung	connecting tube	tuyau de connexion
			200	80047*	1	Magnetventil	solenoid valve	électrovanne

*

Option

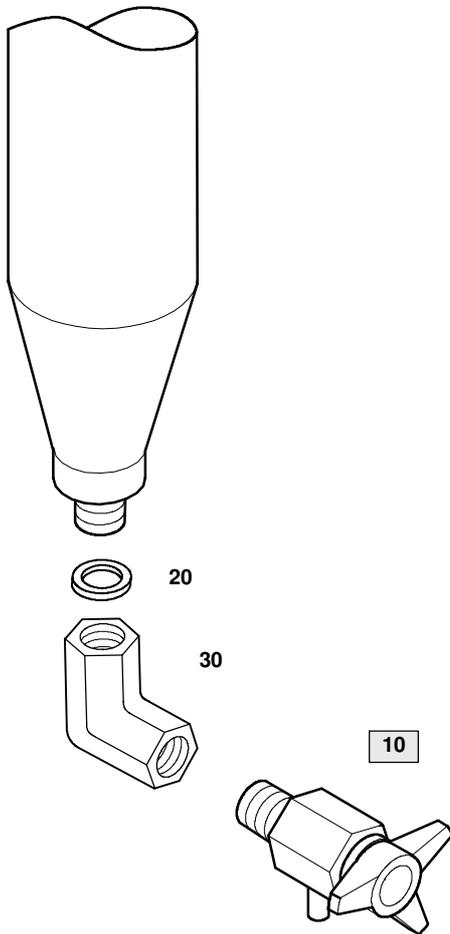

Wartungssätze
Maintenance sets
Kits d'entretien

Baugruppe 81758 **Kondensatablaßhahn**
Assembly 81758 **Condensate drain tap**
Assemblage 81758 **Robinet de purge**

A1.7- 13

Klasse/ Class/ Classe			Pos.	Bestell-Nr. Part No. No. de cde.	Anz. Qty. Qté.	Benennung	Designation	Dénomination
0	2	5						
			10	011430	1	Ablaßhahnkörper, kpl.	drain valve body	corps de robinet de purge
X			20	N19368	1	Dichtung	gasket	joint
			30	N26972	1	W-Verschraubung	elbow coupling	coude

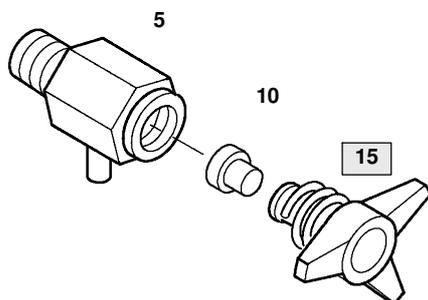
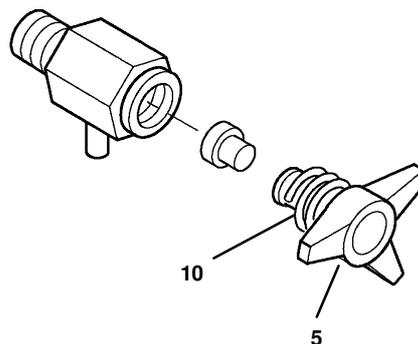
A1.7- 13a

A1.7- 13b

Wartungssätze
Maintenance sets
Kits de maintenance
Baugruppe 011430 Kondensatablaßhahn
Assembly 011430 Condensate drain tap
Assemblage 011430 Robinet de purge
A1.7- 13a

Klasse/ Class/ Classe			Pos.	Bestell-Nr. Part No. No. de cde.	Anz. Qty. Qté.	Benennung	Designation	Dénomination
0	2	5						
			5	068410	1	Abläßhahnkörper, kpl.	drain valve housing	corps de robinet de purge
X			10	13283	1	Dichtung	gasket	joint
			15	055888	1	Knebelschraube m. Feder	tommy screw with spring	molette avec ressort

Wartungssätze
Maintenance sets
Kits de maintenance
Baugruppe 055888 Knebelschraube mit Sicherungsfeder
Assembly 055888 Tommy screw with retaining spring
Assemblage 055888 Molette avec ressort
A1.7- 13b

Klasse/ Class/ Classe			Pos.	Bestell-Nr. Part No. No. de cde.	Anz. Qty. Qté.	Benennung	Designation	Dénomination
a	b	c						
			5	11392	1	Knebelschraube	tommy screw	molette
			10	13284	1	Sicherungsfeder	locking spring	ressort d'arrêt

Ersatzteilliste	B64.0	Filtersystem
Spare parts catalogue	B64.0	Filter system
Liste des pièces	B64.0	Système de filtration



Mini-Verticus III
 Mini-Verticus III
 Mini-Verticus III

Baugruppe	Assembly	Assemblage	Bild/Fig.
Endabscheider	Final separator	Séparateur d'huile et d'eau	B64.0- 1
Filterbehälter P41	Filter P41	Filtre P41	B64.0- 2
Filterbehälter P61	Filter P61	Filtre P61	B64.0- 3

HINWEIS

Diese Ersatzteilliste ist für unterschiedliche Konfigurationen gültig; Der tatsächliche Lieferumfang kann insbesondere bei den Anbau- und Zubehörteilen von den dargestellten Baugruppen und Teilen abweichen.

NOTE

This parts list covers different configurations; the delivery scope, especially for the mounting and accessory parts may differ from the assemblies and parts shown.

NOTE

Cette liste de pièces est valable pour des configurations diverses; il est donc possible que les pièces et les assemblages livrés soient différents des pièces et assemblages indiqués, en particulier les pièces destinées au montage et les accessoires.

Änder.-Nr. Change no. No. de change	Datum Date	Änderung	Change	Changement
0	01.10.2006	Grundaussgabe	Basic edition	Edition de base

Wichtige Hinweise für Teilebestellung:

Bestell-Nr., die mit der Ziffer 0 beginnen, bezeichnen Baugruppen, die komplett geliefert werden. Teile ohne Bestell-Nr. sind nur zur Information für die Montage aufgeführt. Sie sind nicht als Ersatzteil erhältlich. Bei Ersatzteilbestellungen erwarten Sie unsere richtige Lieferung; deshalb benötigen wir von Ihnen folgende Angaben (siehe unten gezeigtes Typenschild):

1. Modellbezeichnung, Fabrik-Nr. sowie Fertigungsstand von Anlage/Block
2. Stückzahlen
3. Benennung und Best.-Nr. des gewünschten Teils

Bestell-Beispiel:

Für Kompressorblock ...
Fabrik-Nr. 524-0528/1/2 drei Dichtungen
8263-090

Important notes for spare parts orders:

Part nos. beginning with digit 0 indicate parts available as complete assemblies. Parts without part no. are indicated for assembly reference, only. These parts are not available as single parts. When placing an order for spare parts, please give the following items so as to ensure our correct delivery (see identification plate shown below):

1. Model, serial no. as well as design standard of unit/block
2. Quantity required
3. Name and part no.

Example for order:

For compressor block ...
serial no. 524-0528/1/2, three gaskets
8263-090

Avis important pour la commande de pièces:

Les nos. de commande commençant par le chiffre 0 indiquent les pièces livrées au complet. Les pièces sans no. de commande sont indiquées uniquement pour information de montage. Elles ne sont pas livrées individuellement. Pour que la livraison de pièces de rechange corresponde à la commande, veuillez bien nous fournir les données suivantes (voir plaque d'identité ci-dessous):

1. Modèle, no. de série et standard de construction de bloc compresseur/groupe
2. Quantité désirée
3. Dénomination et no. de commande de la pièce désirée

Exemple de commande:

Pour bloc compresseur ...
no. de série 524-0528/1/2, trois joints no. de cde. 8263-090



Wartungssätze

- a =Wartungssatz 1000 h
- b =Wartungssatz 2000 h
- c =Wartungssatz 4000 h

In den Spalten sind die im entsprechenden Satz enthaltenen Teile angekreuzt. Bitte beachten, daß die höheren Sätze die untergeordneten nicht beinhalten, d.h. für eine 4000-Stunden-Wartung wird 1x Satz a, 1x Satz b und 1x Satz c benötigt.



Maintenance kit

- a = Maintenance kit 1000 h
- b = Maintenance kit 2000 h
- c = Maintenance kit 4000 h

The columns contain the parts that are included in the respective parts set. Please note that the higher graded kits do not include the lower ones, i.e. for a 4000 hours maintenance, one kit a, one kit b plus one kit c are required.



Kits de pièces d'entretien :

- a = Kit d'entretien 1000 h
- b = Kit d'entretien 2000 h
- c = Kit d'entretien 4000 h

Les pièces contenues dans les kits correspondants sont marquées d'une croix dans les colonnes. Veuillez observer que les kits supérieurs ne contiennent pas les kits subordonnés, c'est-à-dire pour un entretien de 4000 heures il faut avoir 1x kit a, 1x kit b et 1x kit c.

**Anmerkungen zur Identifikation:
Remarks for identification:
Remarques pour l'identification:**

Modell/Model/Modèle		Fabrik-Nr./Serial no./Numéro de série	
<input type="text"/>		<input type="text"/>	
Volumenstrom m ³ /min		Jahr	KB 73708
Free air delivery Scfm		n/min	
Betriebsüberdruck bar		r.p.m.	
Max. working press. psig		kW	
		Fertigungsstand / Modification no. / No. de modification	
		Anlage/Unit/Groupe	
		Kompressorblock/ Compressor block/ Bloc compresseur	



Nur Schrauben und Stiftschrauben der Qualität 8.8 verwenden!



Use only screws and studs in quality 8.8! This quality is equivalent to SAE J 429 d grade 5.



N'utiliser que des vis et des goujons filetés de la qualité 8.8!

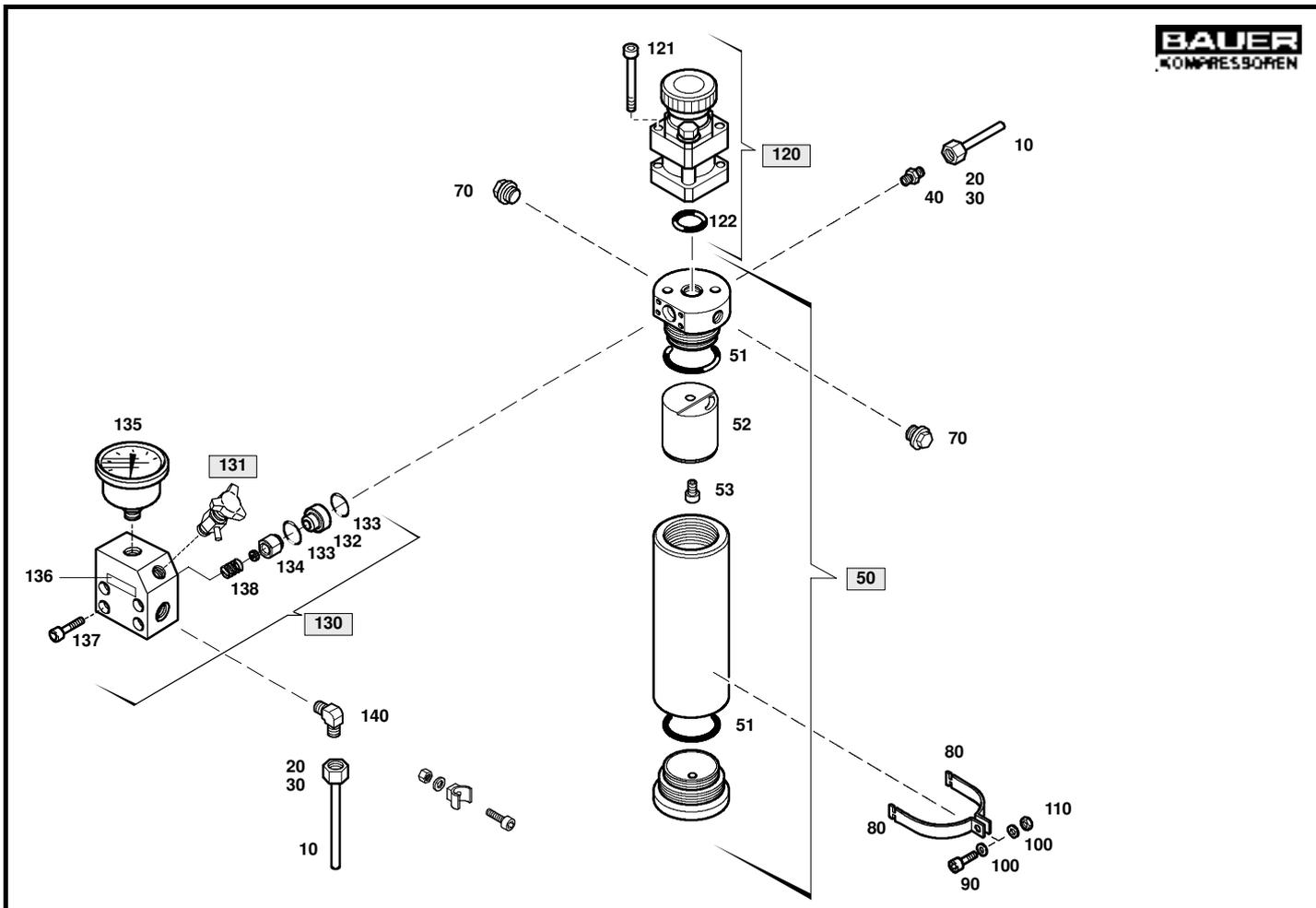

	Wartungssätze Mainenance kits Kits d'entretien	Baugruppe Assembly Assemblage	Endabscheider Final separator Séparateur final	B64.0- 1
--	---	--	---	-----------------

Klasse/ Class/ Classe			Pos.	Bestell-Nr. Part No. No. de cde.	Benennung	Designation	Dénomination
a	b	c					
			10	N3619	Rohr	hose	tuyau
			20	N3608	Überwurfmutter	screw cap	écrou-chapeau
			30	N3609	Schneidring	cutting ring	bague coupante
			40	N20211	G-Einschraubstutzen	straight male coupling	raccord
			50	83111-EU	Öl- und Wasserabscheider, PN370	oil and water separator, PN370	séparateur d'huile et d'eau, PN370
X			51	N4586	O-Ring	o-ring	joint torique
			52	84823	Schutzkappe	protecting bell	cloche
			53	81643	Hohlschraube	hole screw	vis creuse
			60	N4602	USIT-Ring	usit-ring	joint usit
			70	N17133	Verschlusschraube	screwing plug	bouchon
			80	78115	Schelle	clamp	collier
			90	N19535	Zylinderschraube	allen screw	vis allen
			100	N102	Scheibe	washer	rondelle
			110	N1042	Sechskantmutter	nut	écrou
			120	059410*	Sicherheitsventil	safety valve	soupape de sûreté
			121	N19555	Zylinderschraube	allen screw	vis allen
			122	N4882	O-Ring	o-ring	joint torique
			130	78122	Rückschlagventil	non-return valve	clapet anti-retour
			131	011430**	Knebelschraube	condensate drain knob	robinet de purge
			132	63843	Ventilsitz	non-return valve seat	siège de clapet anti-ret.
			133	N4178	O-Ring	o-ring	joint torique
			134	056674	Ventilkolben	valve piston	soupape de piston
			135	N17062	Manometer	gauge	manomètre
			136	64179	Schild	label	vignette
			137	N19538	Zylinderschraube	cylinder screw	vis à six pans creux
			138	3089	Druckfeder	Pressure spring	Ressort
			140	N20172	W-Einschraubstutzen	elbow male coupling	raccord coudé

 *
 **

 Druck bei Bestellung angeben
 Siehe A1.7- 13

 Indicate pressure on order
 Refer to A1.7- 13

 Indiquer la pression sur la commande
 Voir A1.7- 13

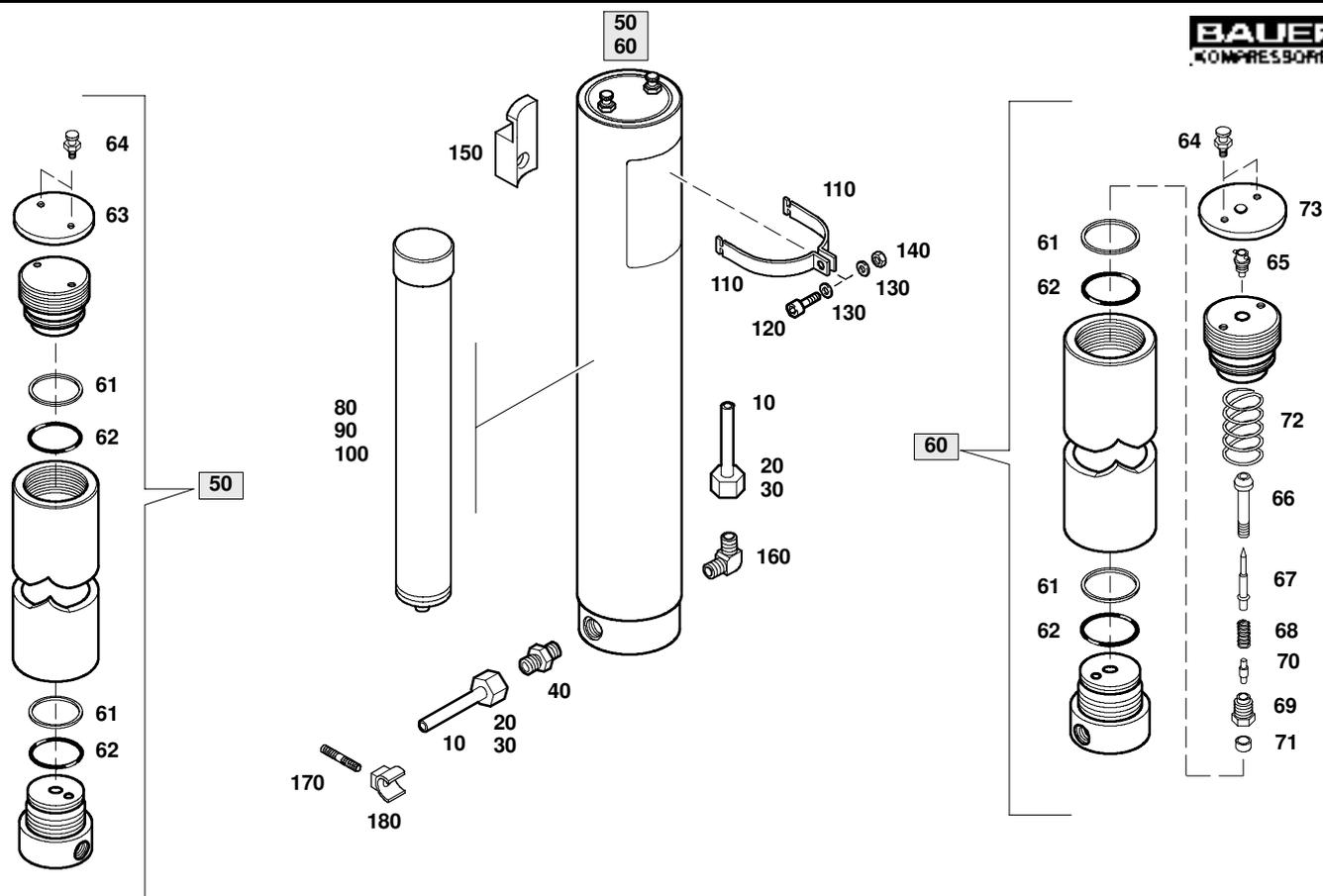
 Wartungssätze
 Maintenance kits
 Kits d'entretien

Baugruppe P41-Filter
Assembly P41 filter
Assemblage Filtre P41
B64.0- 2

Klasse/ Class/ Classe			Pos.	Bestell-Nr. Part No. No. de cde.	Anz. Qty. Qté.	Benennung	Designation	Dénomination
a	b	c						
			10	N3619		Rohr	hose	tuyau
			20	N3608	1	Überwurfmutter	screw cap	écrou-chapeau
			30	N3609	1	Schneidring	cutting ring	bague coupante
			40	N20211	1	G-Einschraubstutzen	straight male coupling	raccord
			50	062042-EU	3	Filterbehälter, 20", Standard	filter, 20", standard	filtre, 20", standard
			60	061685-EU	1	Filterbehälter, 20", Securus	filter, 20", Securus	filtre, 20", Securus
X			61	N4736	2	Stützring	back-up ring	bague d'appui
X			62	N4735	2	O-Ring	o-ring	joint torique
			63	61237	1	Schutzdeckel	protective cover	couvercle protecteur
			64	12293	2	Schraube	screw	vis
			65	59850	1	Buchse BNC	socket BNC	Prise BNC
			66	59851	1	Bolzen	bolt	boulon creux
			67	59853	1	Stift	stud	goupille
			68	60062	1	Druckfeder	spring	ressort
			69	59852	1	Schraube	screw	vis
			70	59854	1	Stift	stud	goupille
			71	59855	1	Mutter	nut	écrou
			72	2181	1	Druckfeder	spring	ressort
			73	60135	1	Schutzdeckel	protective cover	couvercle protecteur
			80	062565	1	Filterpatrone, H ₂ O-Oel	filter cartridge, H ₂ O-Oil	cartouche, H ₂ O-huile
			90	061686	1	Filterpatrone, Securus, H ₂ O-Oel	filter cartridge, Securus, H ₂ O-Oil	cartouche, Securus, H ₂ O-huile
			100	061687	1	Filterpatrone, Securus, H ₂ O-Oel-CO	filter cartridge, Securus, H ₂ O-Oil-CO	cartouche, Securus, H ₂ O-huile-CO
			110	84110	4	Schelle	clamp	collier
			120	N19535	2	Zylinderschraube	allen screw	vis allen
			130	N102	4	Scheibe	washer	rondelle
			140	N1042	2	Sechskantmutter	nut	écrou
			150	61933	2	Halterung	support	support
			160	N7727	1	W-Einschraubstutzen	elbow male coupling	raccord coudé
			170	N3202	4	Rohrclip	tube clamp	collier
			180	N7490	4	Gewindestift	stud	goujon

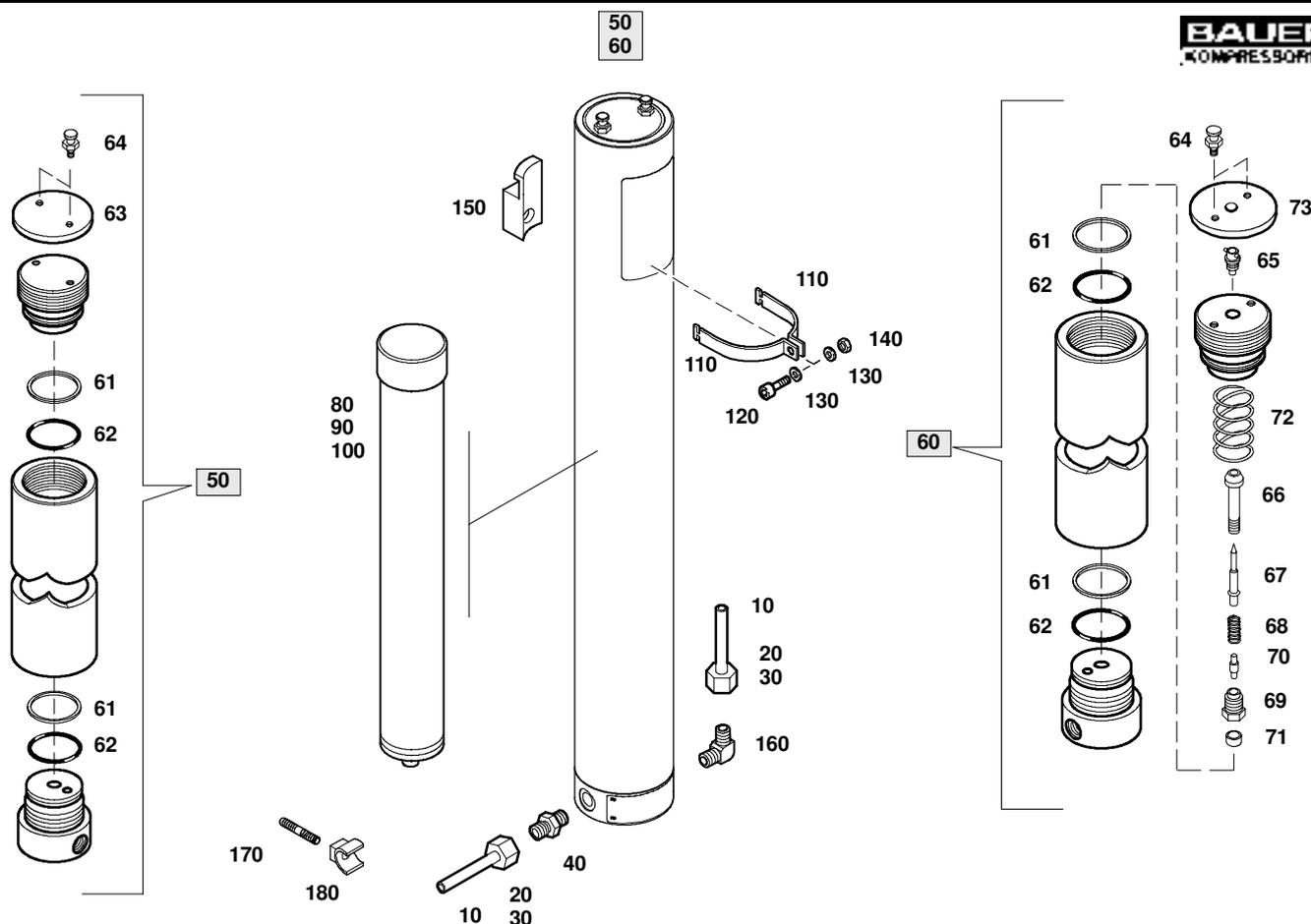

Wartungssätze
 Maintenance kits
 Kits d'entretien

Baugruppe P61-Filter
 Assembly P61 filter
 Assemblage Filtre P61

B64.0- 3

Klasse/ Class/ Classe			Pos.	Bestell-Nr. Part No. No. de cde.	Anz. Qty. Qté.	Benennung	Designation	Dénomination
a	b	c						
			10	N3619		Rohr	hose	tuyau
			20	N3608	1	Überwurfmutter	screw cap	écrou-chapeau
			30	N3609	1	Schneidring	cutting ring	bague coupante
			40	N20211	1	G-Einschraubstutzen	straight male coupling	raccord
			50	061082-EU	1	Filterbehälter, 27", Standard	filter, 27", standard	filtre, 27", standard
			60	061224-EU	1	Filterbehälter, 27", Securus	filter, 27", Securus	filtre, 27", Securus
X			61	N4736	2	Stützring	back-up ring	bague d'appui
X			62	N4735	2	O-Ring	o-ring	joint torique
			63	61237	1	Schutzdeckel	protective cover	couvercle protecteur
			64	12293	2	Schraube	screw	vis
			65	59850	1	Buchse BNC	socket BNC	Prise BNC
			66	59851	1	Bolzen	bolt	boulon creux
			67	59853	1	Stift	stud	goupille
			68	60062	1	Druckfeder	spring	ressort
			69	59852	1	Schraube	screw	vis
			70	59854	1	Stift	stud	goupille
			71	59855	1	Mutter	nut	écrou
			72	2181	1	Druckfeder	sprinc	ressort
			73	60135	1	Schutzdeckel	protective cover	couvercle protecteur
			80	058826	1	Filterpatrone, H ₂ O-Oel	filter cartridge, H ₂ O-Oil	cartouche, H ₂ O-huile
			90	060036	1	Filterpatrone, Securus, H ₂ O-Oel	filter cartridge, Securus, H ₂ O-Oil	cartouche, Securus, H ₂ O-huile
			100	060037	1	Filterpatrone, Securus, H ₂ O-Oel-CO	filter cartridge, Securus, H ₂ O-Oil-CO	cartouche, Securus, H ₂ O-huile-CO
			110	78114	4	Schelle	clamp	collier
			120	N19535	2	Zylinderschraube	allen screw	vis allen
			130	N102	4	Scheibe	washer	rondelle
			140	N1042	2	Sechskantmutter	nut	écrou
			150	61933	2	Halterung	support	support
			160	N7727	1	W-Einschraubstutzen	elbow male coupling	raccord coudé
			170	N3202	4	Rohrclip	tube clamp	collier
			180	N7490	4	Gewindestift	stud	goujon

Ersatzteilliste C75.0
 Spare parts catalogue C75.0
 Liste des pièces C75.0

Kondensat-Ablaufautomatik
 Automatic condensate drain unit
 Purge automatique des condensats



Mini-Verticus III

Baugruppe	Assembly	Assemblage	Bild/Fig.
Kondensat-Ablaufautomatik	Automatic cond. drain unit	Purge automatique des condensats	C75.0- 1
Kondensatablaufventil 84184	Condensate drain valve 84184	Soupape de purge cpl. 84184	C75.0- 2
Kondensatablaufventil 81457	Condensate drain valve 81457	Soupape de purge cpl. 81457	C75.0- 3

Änder.-Nr. Change no. No. de change	Datum Date	Änderung	Change	Changement
0	01.10.2006	Grundausgabe	Basic edition	Edition de base

Wichtige Hinweise für Teilebestellung:

Bestell-Nr., die mit der Ziffer 0 beginnen, bezeichnen Baugruppen, die komplett geliefert werden. Teile ohne Bestell-Nr. sind nur zur Information für die Montage aufgeführt. Sie sind nicht als Ersatzteil erhältlich. Bei Ersatzteilbestellungen erwarten Sie unsere richtige Lieferung; deshalb benötigen wir von Ihnen folgende Angaben (siehe unten gezeigtes Typenschild):

1. Modellbezeichnung, Fabrik-Nr. sowie Fertigungsstand von Anlage/Block
2. Stückzahlen
3. Benennung und Best.-Nr. des gewünschten Teils

Bestell-Beispiel:

Für Kompressorblock ...
Fabrik-Nr. 524-0528/1/2 drei Dichtungen
8263-090

Important notes for spare parts orders:

Part nos. beginning with digit 0 indicate parts available as complete assemblies. Parts without part no. are indicated for assembly reference, only. These parts are not available as single parts. When placing an order for spare parts, please give the following items so as to ensure our correct delivery (see identification plate shown below):

1. Model, serial no. as well as design standard of unit/block
2. Quantity required
3. Name and part no.

Example for order:

For compressor block ...
serial no. 524-0528/1/2, three gaskets
8263-090

Avis important pour la commande de pièces:

Les nos. de commande commençant par le chiffre 0 indiquent les pièces livrées au complet. Les pièces sans no. de commande sont indiquées uniquement pour information de montage. Elles ne sont pas livrées individuellement. Pour que la livraison de pièces de rechange corresponde à la commande, veuillez bien nous fournir les données suivantes (voir plaque d'identité ci-dessous):

1. Modèle, no. de série et standard de construction de bloc compresseur/groupe
2. Quantité désirée
3. Dénomination et no. de commande de la pièce désirée

Exemple de commande:

Pour bloc compresseur ...
no. de série 524-0528/1/2, trois joints no. de cde. 8263-090



Wartungssätze

- a =Wartungssatz 1000 h
- b =Wartungssatz 2000 h
- c =Wartungssatz 4000 h



Maintenance kit

- a = Maintenance kit 1000 h
- b = Maintenance kit 2000 h
- c = Maintenance kit 4000 h



Kits de pièces d'entretien :

- a = Kit d'entretien 1000 h
- b = Kit d'entretien 2000 h
- c = Kit d'entretien 4000 h

In den Spalten sind die im entsprechenden Satz enthaltenen Teile angekreuzt. Bitte beachten, daß die höheren Sätze die untergeordneten nicht beinhalten, d.h. für eine 4000-Stunden-Wartung wird 1x Satz a, 1x Satz b und 1x Satz c benötigt.

The columns contain the parts that are included in the respective parts set. Please note that the higher graded kits do not include the lower ones, i.e. for a 4000 hours maintenance, one kit a, one kit b plus one kit c are required.

Les pièces contenues dans les kits correspondants sont marquées d'une croix dans les colonnes. Veuillez observer que les kits supérieurs ne contiennent pas les kits subordonnés, c'est-à-dire pour un entretien de 4000 heures il faut avoir 1x kit a, 1x kit b et 1x kit c.

Anmerkungen zur Identifikation:
Remarks for identification:
Remarques pour l'identification:

Modell/Model/Modèle		Fabrik-Nr./Serial no./Numéro de série	
<input type="text"/>		<input type="text"/>	
Volumenstrom m ³ /min		Jahr	KB 73708
Free air delivery Scfm		Year	
Betriebsüberdruck bar		n/min.	
Max. working press. psig		r.p.m.	Fertigungsstand / Modification no. / No. de modification
		kW	Anlage/Unit/Groupe
			Kompressorblock/ Compressor block/ Bloc compresseur



ACHTUNG

Nur Schrauben und Stiftschrauben der Qualität 8.8 verwenden!



ATTENTION

Use only screws and studs in quality 8.8! This quality is equivalent to SAE J 429 d grade 5.



ATTENTION

N'utiliser que des vis et des goujons filetés de la qualité 8.8!

Sonderausstattung/option/option:

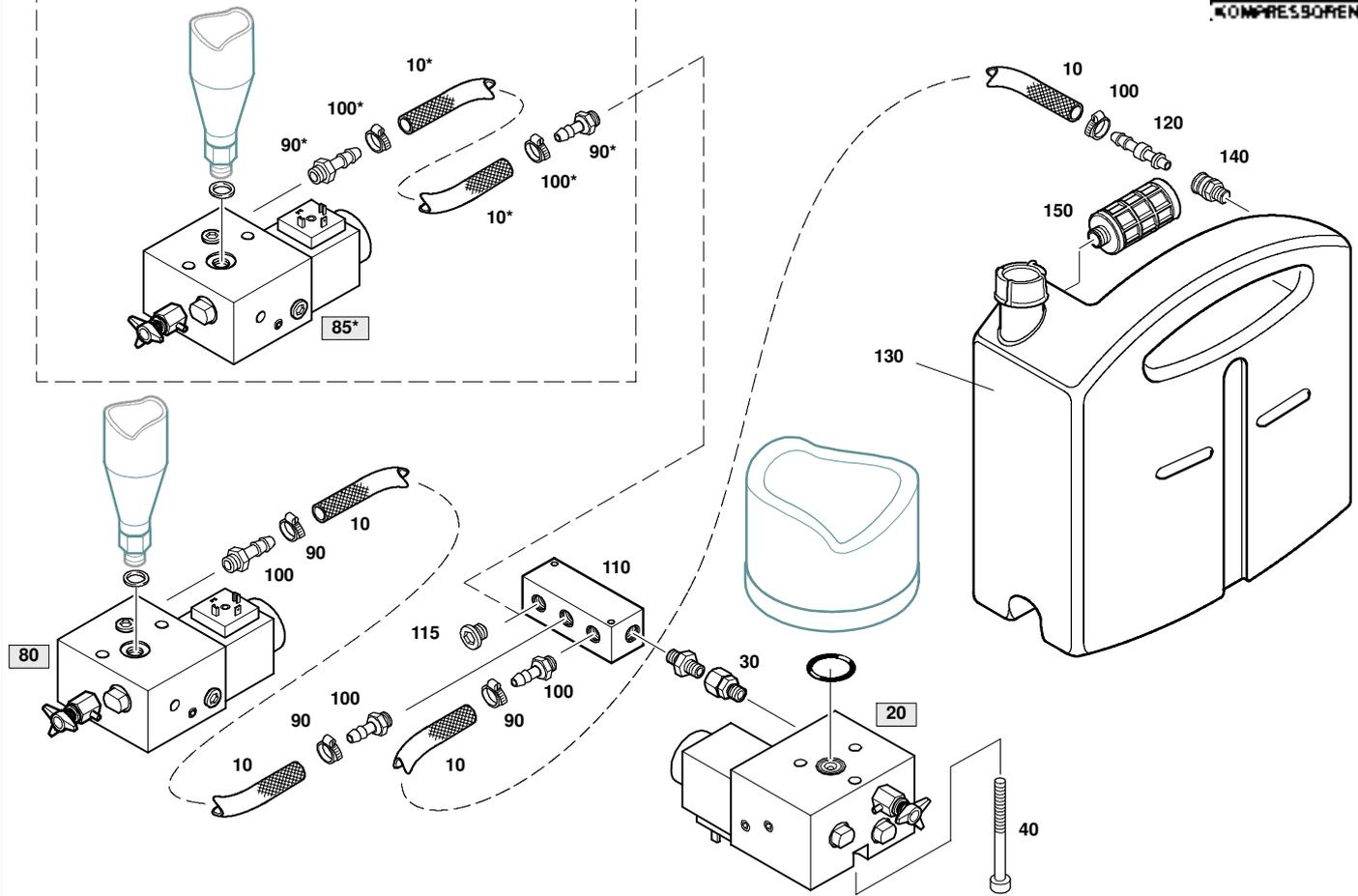

C75.0- 1

 **Wartungssätze**
Mainenance kits
Kits d'entretien

Baugruppe 84163 Kondensat-Ablaufautomatik kpl.
Assembly 84163 Automatic condensate drain assy.
Assemblage 84163 Purge automatique des condensats cpl.

Klasse/ Class/ Classe			Pos.	Bestell-Nr. Part No. No. de cde.	Anz. Qty. Qté.	Benennung	Designation	Dénomination
a	b	c						
			10	N3126	mm*	Schlauch	hose	tuyau
			20	84184	1	Kondensatventil HD	condensate drain valve HP	soupape de purge HP
	X		30	N4857	1	O-Ring	o-ring	joint torique
			40	N19555	3	Zylinderschraube	allen screw	vis à six pans creux
			80	81457	1	Kondensatventil MD	condensate drain valve MP	soupape de purge MP
			85*	81457	1	Kondensatventil MD	condensate drain valve MP	soupape de purge MP
			90	N28551	4	Schlauchtülle	hose coupling	raccord de tuyau
			100	N3133	7	Schlauchklemme	hose clamp	collier
			110	N29856	1	Verteiler	manifold	distributeur
			115	N27162	1	Verschlußschraube	screwing plug	bouchon
			120	N17180	1	Stecktülle	hose coupling	raccord
			130	81759-01	1	Kondensatbehälter	condensate collector	réservoir à condensats
			140	N17179	1	Kupplung	quick coupling	raccord rapide
			150	N3512	1	Schalldämpfer	silencer	silencieux
			160	N19368	1	Kupferring	gasket	joint

*

Nur Anlagen mit Zwischenfilter nach 1.Stufe

Only groups with filter after 1st stage

Seuls groupes avec filtre après le 1er étage

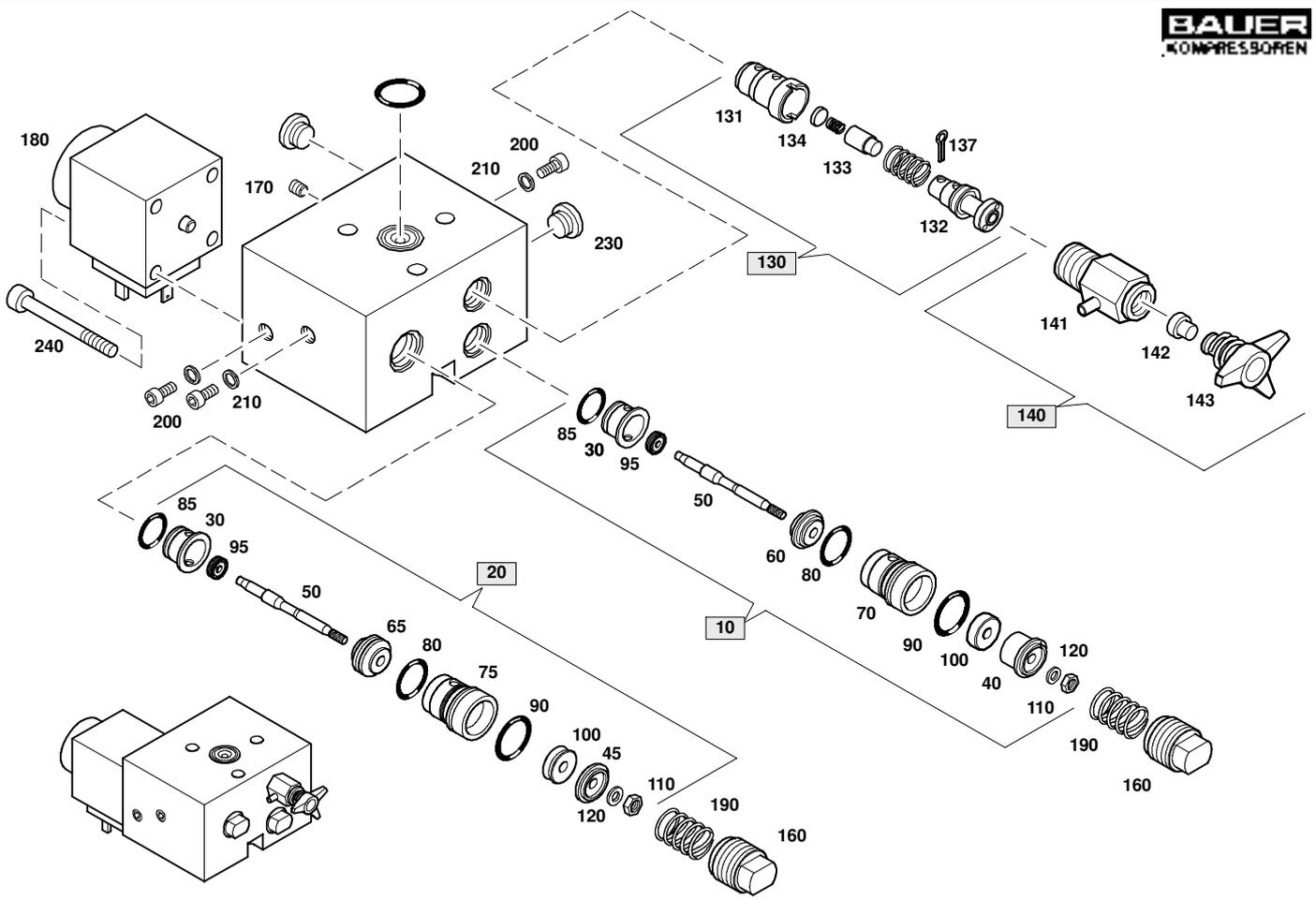



Wartungssätze
Mainenance kits
Kits d'entretien

Baugruppe 84184
Assembly 84184
Assemblage 84184

Kondensat-Ablaßventil, HD
Condensate drain valve, HP
Soupage de purge des condensats, HP

C75.0- 2

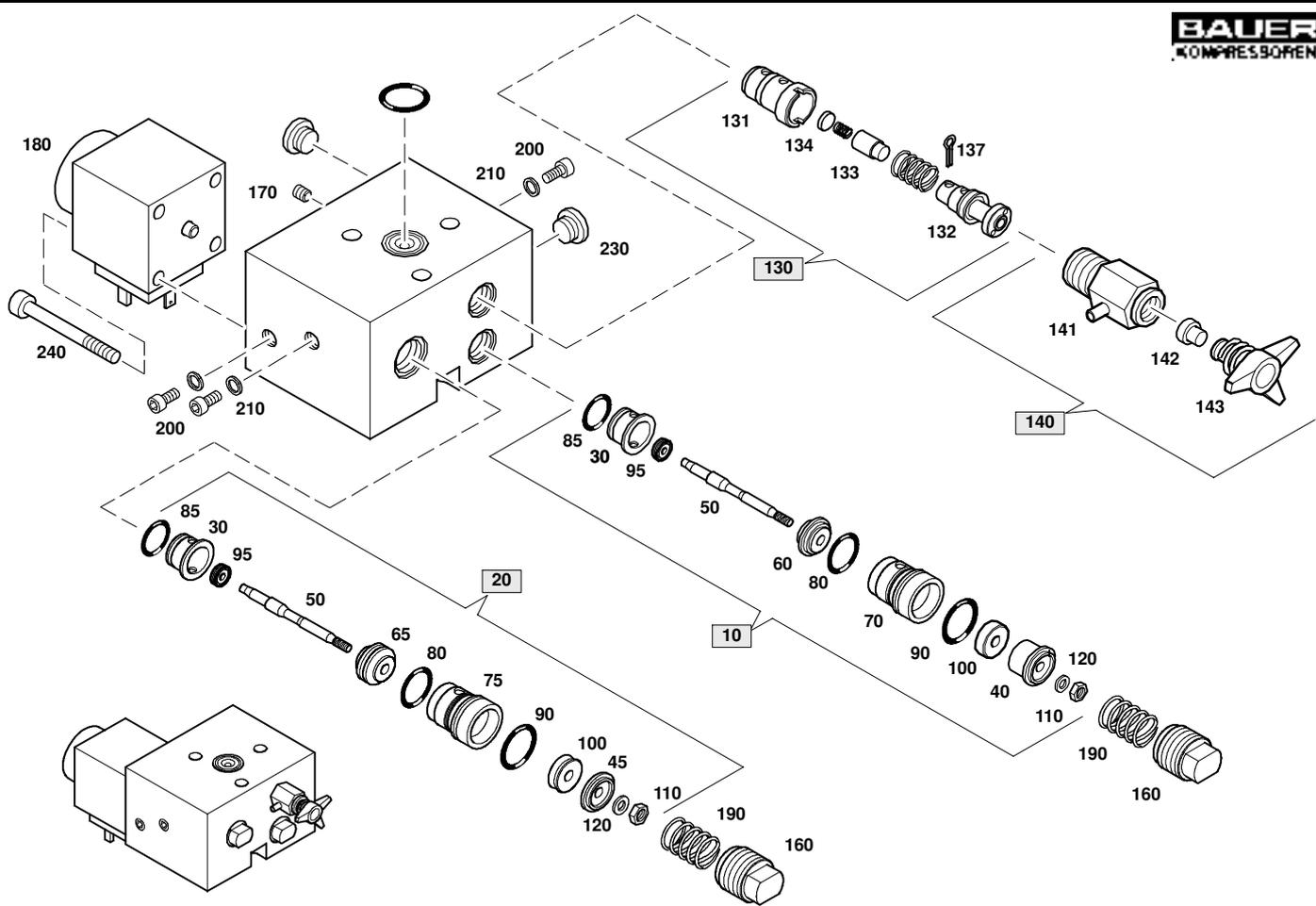
Klasse/ Class/ Classe			Pos.	Bestell-Nr. Part No. No. de cde.	Anz. Qty. Qté.	Benennung	Designation	Dénomination
a	b	c						
			10	81480	1	Ventileinsatz kpl.	valve core assy.	mécanisme de soupape cpl.
			20	81481	1	Ventileinsatz kpl.	valve core assy.	mécanisme de soupape cpl.
			30		1	Buchse	bushing	douille
			40	81461	1	Federteller	spring washer	rondelle-ressort
			45	81490	1	Federteller	spring washer	rondelle-ressort
			50	81487	1	Stift	stud	goupille
X			60	81488	1	Ventilsitz	valve seat	siège de soupape
X			65	81491	1	Ventilsitz	valve seat	siège de soupape
			70	81489	1	Buchse	bushing	douille
			75	81492	1	Buchse	bushing	douille
X			80	N26827	1	O-Ring	o-ring	joint torique
X			85	N1338	1	O-Ring	o-ring	joint torique
X			90	N18333	1	O-Ring	o-ring	joint torique
X			95	N26836	1	Nutring	grouded ring	rondelle à gorge
X			100	N26837	1	Nutring	grouded ring	rondelle à gorge
			110	N26828	1	Sechskantmutter	nut	écrou
			120	N26838	1	Sicherungsscheibe	safety washer	rondelle de sûreté
			130	81482	1	Spaltfilter kpl.	gap filter assy.	filtre à disque cpl.
			131	81466	1	Buchse	bushing	douille
			132		1	Kolben	piston	piston
			133		1	Kolben	piston	piston
			134	81469	1	Federteller	spring washer	rondelle-ressort
			135	N26829	1	Druckfeder	spring	ressort
			136	N26830	1	Druckfeder	spring	ressort
			137	N26831	1	Splint	split pin	goupille
			140	81470	1	Ablaßhahn kpl.	condensate drain tap assy.	robinet de purge cpl.
			141	81471	1	Ablaßhahnkörper	drain valve housing	corps de robinet de purge
			142	13283	1	Dichtung	gasket	joint
			143	055888	1	Knebelschraube m. Feder	tommy screw with spring	molette avec ressort
			160	81484	2	Hülse	sleeve	douille
			170	81475	1	Drosselschraube	nozzle	vis d'étranglement
			180	81476	1	Hubmagnet	solenoid	électro-aimant
			190	N26832	2	Druckfeder	spring	ressort
			200	N24170	3	Zylinderschraube	allen screw	vis à six pans creux
			210	N26839	3	USIT-Ring	usit-ring	joint usit
			220	N26835	1	Gewindestift	stud	goujon



	Wartungssätze Maintenance kits Kits d'entretien	Baugruppe 84184 Assembly 84184 Assemblage 84184	Kondensat-Abläbventil, HD Condensate drain valve, HP Soupape de purge des condensats, HP	C75.0- 2
--	---	---	--	----------

Klasse/ Class/ Classe			Pos.	Bestell-Nr. Part No. No. de cde.	Anz. Qty. Qté.	Benennung	Designation	Dénomination
a	b	c						
			230	N16504	1	Verschlußschraube	screwing plug	bouchon
			240	N17888	4	Zylinderschraube	allen screw	vis à six pans creux

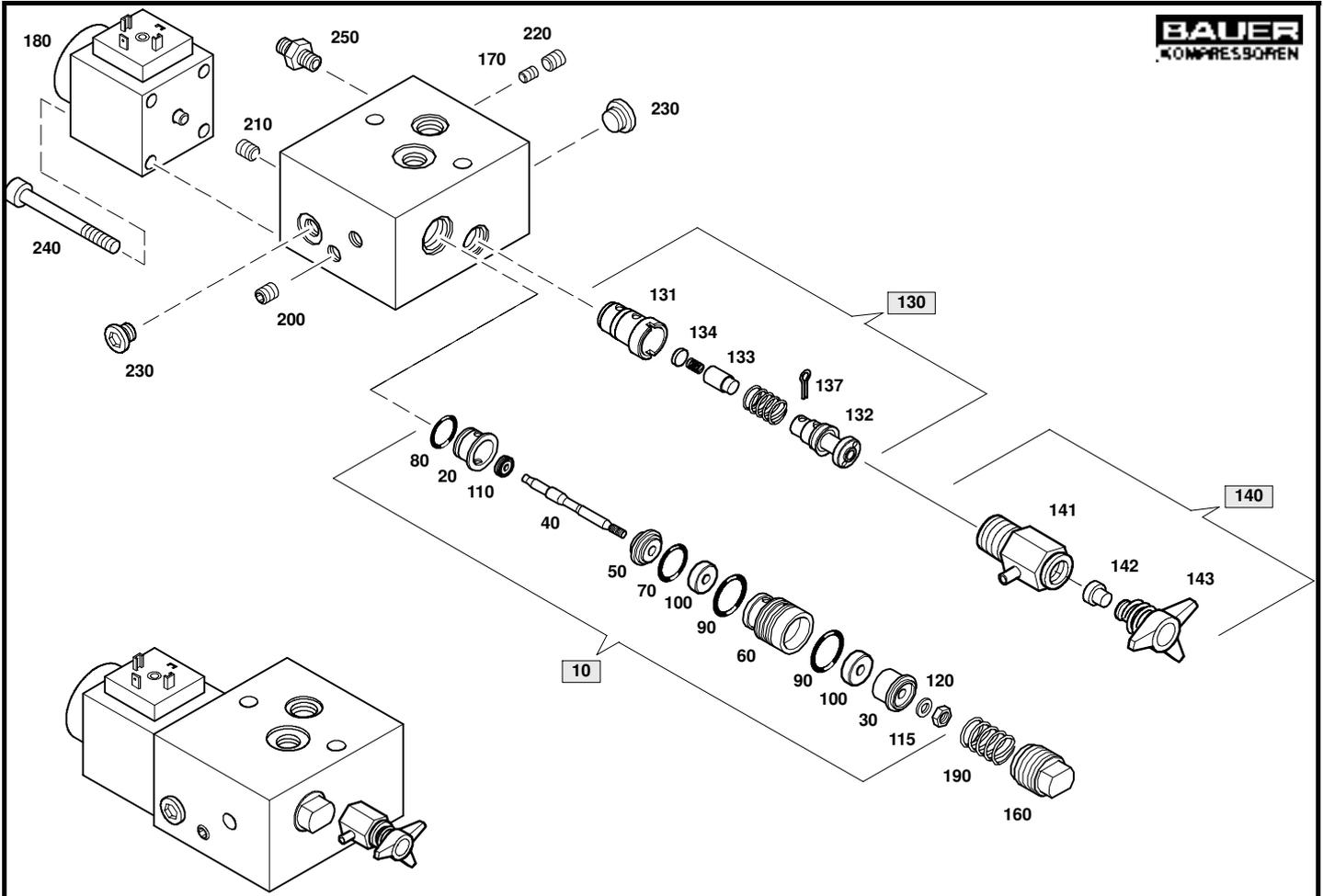

Wartungssätze
Mainenance kits
Kits d'entretien

Baugruppe 81457 **Kondensat-Ablaßventil, MD**
Assembly 81457 **Condensate drain valve, MP**
Assemblage 81457 **Soupepe de purge des condensats, MP**

C75.0- 3

Klasse/ Class/ Classe			Pos.	Bestell-Nr. Part No. No. de cde.	Anz. Qty. Qté.	Benennung	Designation	Dénomination
a	b	c						
			10	81459	1	Ventileinsatz kpl.	valve core assy.	mécanisme de soupape cpl.
			20		1	Buchse	bushing	douille
			30	81461	1	Federteller	spring washer	rondelle-ressort
			40	81462	1	Stift	stud	goupille
X			50	81463	1	Ventilsitz	valve seat	siège de soupape
			60	81464	1	Kolbenbuchse	bushing	douille
X			70	N26827	1	O-Ring	o-ring	joint torique
X			80	N1338	1	O-Ring	o-ring	joint torique
X			90	N18333	2	O-Ring	o-ring	joint torique
X			100	N26836	2	Nutring	grouved ring	rondelle à gorge
X			110	N26837	1	Nutring	grouved ring	rondelle à gorge
			115	N26828	1	Sechskantmutter	nut	écrou
			120	N26838	1	Sicherungsscheibe	safety washer	rondelle de sûreté
			130	81465	1	Spaltfilter kpl.	gap filter assy.	filtre à disque cpl.
			131	81466	1	Buchse	bushing	douille
			132		1	Kolben	piston	piston
			133		1	Kolben	piston	piston
			134	81469	1	Federteller	spring washer	rondelle-ressort
			135	N26829	1	Druckfeder	spring	ressort
			136	N26830	1	Druckfeder	spring	ressort
			137	N26831	1	Splint	split pin	goupille
			140	81470	1	Ablaßhahn kpl.	condensate drain tap assy.	robinet de purge cpl.
			141	81471	1	Ablaßhahnkörper	drain valve housing	corps de robinet de purge
			142	13283	1	Dichtung	gasket	joint
			143	055888	1	Knebschraube m. Feder	tommy screw with spring	molette avec ressort
			160	81473	1	Hülse	sleeve	douille
			170	81475	1	Drosselschraube	nozzle	vis d'étranglement
			180	81476	1	Hubmagnet	solenoid	électro-aimant
			190	N26832	1	Druckfeder	spring	ressort
			200	N26833	1	Expander	expander screw	vis expansive
			210	N26851	1	Expander	expander screw	vis expansive
			220	N26835	1	Gewindestift	stud	goujon
			230	N16504	2	Verschlußschraube	screwing plug	bouchon
			240	N17888	4	Zylinderschraube	allen screw	vis à six pans creux
			250	N20211	1	G-Einschraubstutzen	straight male coupling	raccord

Ersatzteilliste **D17.0** **Armaturentafel Mini-Verticus III**
Spare parts catalogue **D17.0** **Instrument panel Mini-Verticus III**
Liste des pièces **D17.0** **Tableau des instruments Mini-Verticus III**

Baugruppe	Assembly	Assemblage	Bild/Fig.
Abgangsarmaturen	Outlet fittings	Rampe de gonflage	D17.0- 1
Verteilerblock halbautomatisch ... 2xPN200 oder 2xPN300	Manifold semi-automatic	Rampe de gonflage semi-automatique 2xPN200 ou 2xPN300	D17.0- 2
Verteilerblock vollautomatisch ... 2xPN200 oder 2xPN300	Manifold full-automatic	Rampe de gonflage automatique 2xPN200 ou 2xPN300	D17.0- 3
Verteilerblock halbautomatisch ... 1xPN200 und 1xPN300	Manifold semi-automatic	Rampe de gonflage semi-automatique 1xPN200 et 1xPN300	D17.0- 4
Verteilerblock vollautomatisch ... 1xPN200 und 1xPN300	Manifold full-automatic	Rampe de gonflage automatique 1xPN200 et 1xPN300	D17.0- 5
Druckhalteventil	Pressure maintaining valve	Soupape de maintien de pression ...	D17.0- 6
Füllventil	Filling valve	Vanne de remplissage	D17.0- 7
Anschlußleiste	Connecting manifold	Rampe de distribution	D17.0- 8

Änder.-Nr. Change no. No. de change	Datum Date	Änderung	Change	Changement
0	01.10.2006	Grundaussgabe	Basic edition	Edition de base
1				
2				

Wichtige Hinweise für Teilebestellung:

Bestell-Nr., die mit der Ziffer 0 beginnen, bezeichnen Baugruppen, die komplett geliefert werden. Teile ohne Bestell-Nr. sind nur zur Information für die Montage aufgeführt. Sie sind nicht als Ersatzteil erhältlich. Bei Ersatzteilbestellungen erwarten Sie unsere richtige Lieferung; deshalb benötigen wir von Ihnen folgende Angaben (siehe unten gezeigtes Typenschild):

1. Modellbezeichnung, Fabrik-Nr. sowie Fertigungsstand von Anlage/Block
2. Stückzahlen
3. Benennung und Best.-Nr. des gewünschten Teils

Bestell-Beispiel:

Für Kompressorblock ...
Fabrik-Nr. 524-0528/1/2 drei Dichtungen
8263-090

Important notes for spare parts orders:

Part nos. beginning with digit 0 indicate parts available as complete assemblies. Parts without part no. are indicated for assembly reference, only. These parts are not available as single parts. When placing an order for spare parts, please give the following items so as to ensure our correct delivery (see identification plate shown below):

1. Model, serial no. as well as design standard of unit/block
2. Quantity required
3. Name and part no.

Example for order:

For compressor block ...
serial no. 524-0528/1/2, three gaskets
8263-090

Avis important pour la commande de pièces:

Les nos. de commande commençant par le chiffre 0 indiquent les pièces livrées au complet. Les pièces sans no. de commande sont indiquées uniquement pour information de montage. Elles ne sont pas livrées individuellement. Pour que la livraison de pièces de rechange corresponde à la commande, veuillez bien nous fournir les données suivantes (voir plaque d'identité ci-dessous):

1. Modèle, no. de série et standard de construction de bloc compresseur/groupe
2. Quantité désirée
3. Dénomination et no. de commande de la pièce désirée

Exemple de commande:

Pour bloc compresseur ...
no. de série 524-0528/1/2, trois joints no. de cde. 8263-090



Wartungssätze

- a = Wartungssatz 500 h
- b = Wartungssatz 1000 h
- c = Wartungssatz 2000 h



Maintenance kit

- a = Maintenance kit 500 h
- b = Maintenance kit 1000 h
- c = Maintenance kit 2000 h



Kits de pièces d'entretien :

- a = Kit d'entretien 500 h
- b = Kit d'entretien 1000 h
- c = Kit d'entretien 2000 h

In den Spalten sind die im entsprechenden Satz enthaltenen Teile angekreuzt. Bitte beachten, daß die höheren Sätze die untergeordneten nicht beinhalten, d.h. für eine 4000-Stunden-Wartung wird 1x Satz a, 1x Satz b und 1x Satz c benötigt.

The columns contain the parts that are included in the respective parts set. Please note that the higher graded kits do not include the lower ones, i.e. for a 4000 hours maintenance, one kit a, one kit b plus one kit c are required.

Les pièces contenues dans les kits correspondants sont marquées d'une croix dans les colonnes. Veuillez observer que les kits supérieurs ne contiennent pas les kits subordonnés, c'est-à-dire pour un entretien de 4000 heures il faut avoir 1x kit a, 1x kit b et 1x kit c.

Anmerkungen zur Identifikation:

Remarks for identification:

Remarques pour l'identification:

Modell/Model/Modèle		Fabrik-Nr./Serial no./Numéro de série	
<input type="text"/>		<input type="text"/>	
-		Jahr / Year	<input type="text"/>
/		n/min. / r.p.m.	<input type="text"/>
Volumenstrom m ³ /min	<input type="text"/>	kW	<input type="text"/>
Free air delivery Scfm	<input type="text"/>	KB 73708	<input type="text"/>
Betriebsüberdruck bar	<input type="text"/>	Fertigungsstand / Modification no. / No. de modification	
Max. working press. psig	<input type="text"/>	Anlage/Unit/Groupe	
		Kompressorblock / Compressor block / Bloc compresseur	



ACHTUNG

Nur Schrauben und Stiftschrauben der Qualität 8.8 verwenden!



ATTENTION

Use only screws and studs in quality 8.8! This quality is equivalent to SAE J 429 d grade 5.



ATTENTION

N'utiliser que des vis et des goujons filetés de la qualité 8.8!

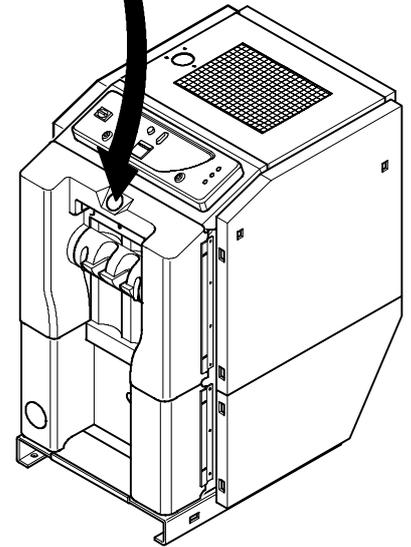
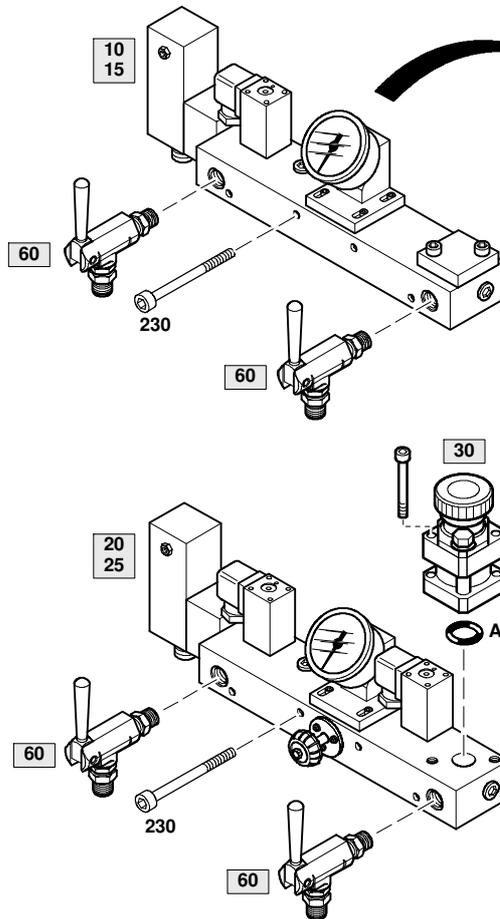
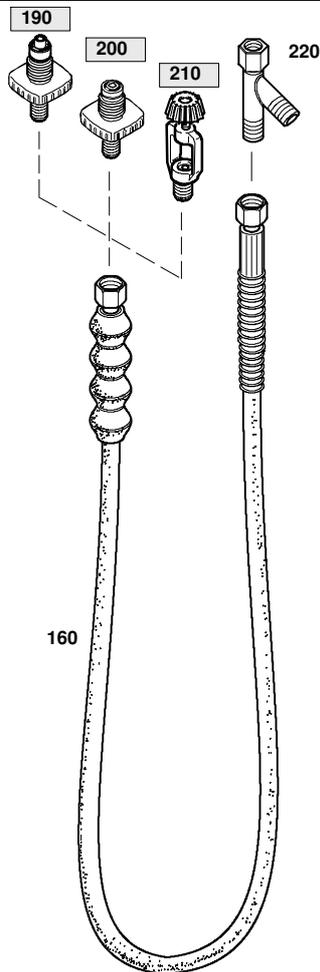

Wartungssätze
 Maintenance sets
 Kits de maintenance

Baugruppe 83018
 Assembly 83018
 Assemblage 83018

Abgangsarmaturen
 Filling panel
 Rampe de gonflage

D17.0- 1

Klasse/ Class/ Classe			Pos.	Bestell-Nr. Part No. No. de cde.	Anz. Qty. Qté.	Benennung	Designation	Dénomination
a	b	c						
			10	84167	1	Verteilerblock halbautomatisch kpl. 2xPN200 oder 2xPN300	manifold semi-automatic assy. 2xPN200 or 2xPN300	bloc distributeur semi-automatique 2xPN200 ou 2xPN300
			15	84167-S01	1	Verteilerblock vollautomatisch kpl. 2xPN200 oder 2xPN300	manifold automatic assy. 2xPN200 or 2xPN300	bloc distributeur automatique 2xPN200 ou 2xPN300
			20	82450	1	Verteilerblock halbautomatisch kpl. 1xPN200 und 1xPN300	manifold semi-automatic assy. 1xPN200 and 1xPN300	bloc distributeur semi-automatique 1xPN200 et 1xPN300
			25	82450-S01	1	Verteilerblock vollautomatisch kpl. 1xPN200 und 1xPN300	manifold automatic assy. 1xPN200 and 1xPN300	bloc distributeur automatique 1xPN200 et 1xPN300
			30	059410-225	1	Sicherheitsventil 225 bar	safety valve 225 bar	soupape de sûreté 225 bar
			60	075353	2	Füllventil	filling valve	vanne de remplissage
			70	N16266	2	Verschlußschraube	plug	bouchon fileté
			160	N2817	2	UNIMAM-Füllschlauch	hose Unimam	tuyau Unimam
			170	65594	1	Banderole, PN200	tape, PN200	bande, PN200
			180	65595	1	Banderole, PN300	tape, PN300	bande, PN300
			190	010912	1	Flaschen-Anschluß, PN300	bottle connection, PN300	raccord de bouteille, PN300
			200	07756	1	Flaschen-Anschluß, PN200	bottle connection, PN200	raccord de bouteille, PN200
			210	03147	1	ISO-Füllanschluß, PN200	ISO filling connection, PN200	raccord de remplissage ISO, PN200
			220	014532	1	Verteiler	double coupling	distributeur
			230	N16075	4	Zylinderschraube m. IN-6KT	allen screw	vis 6 pans creux

X		A	N4882	1	O-Ring	o-ring	joint torique
---	--	---	-------	---	--------	--------	---------------

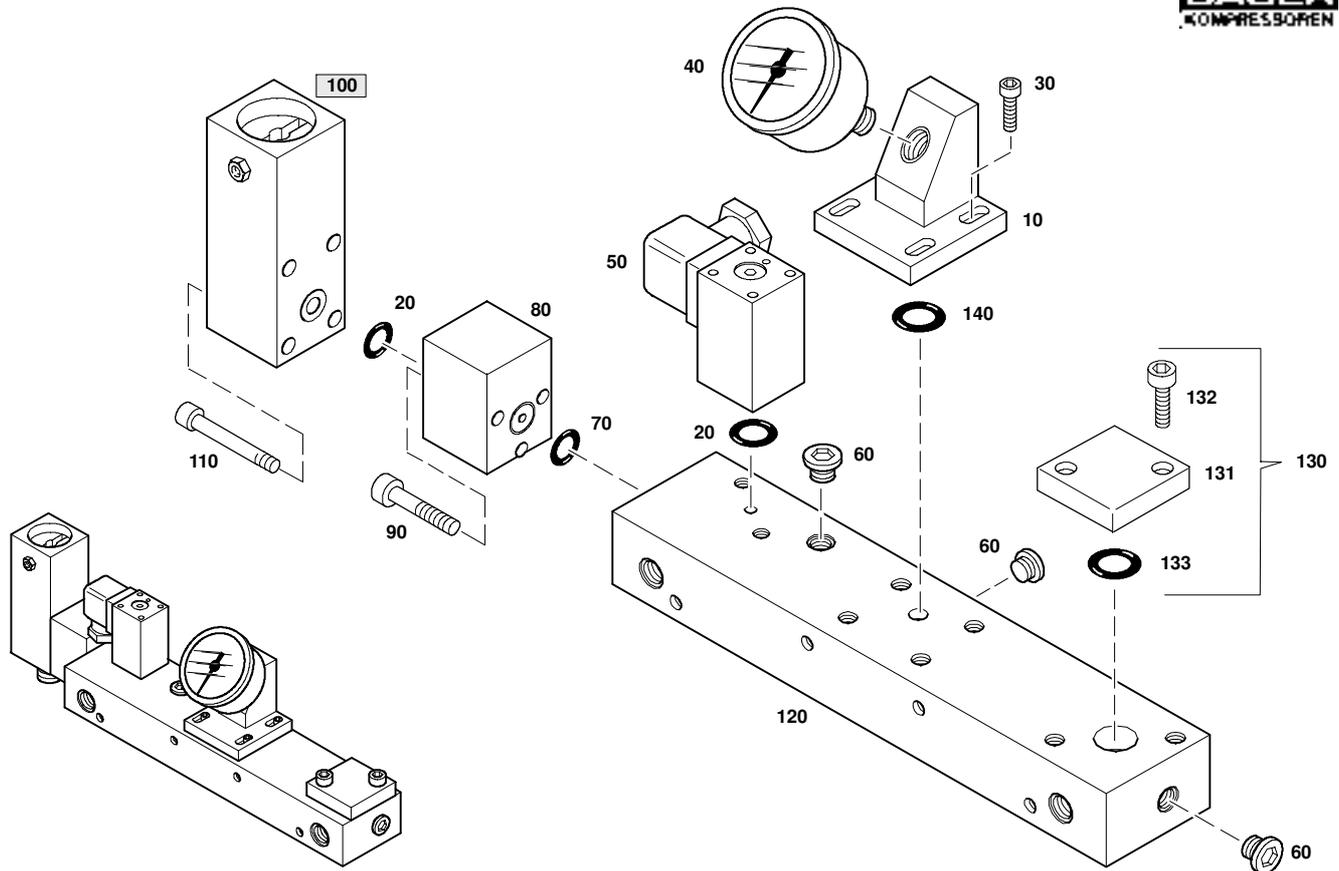

Wartungssätze
 Mainenance sets
 Kits de maintenance

Baugruppe 84167
 Assembly 84167
 Assemblage 84167

Verteilerblock halbautomatisch kpl.
 Semi-automatic outlet manifold assy
 Bloc de distribution semi-automatique cpl.

D17.0- 2

Klasse/ Class/ Classe			Pos.	Bestell-Nr. Part No. No. de cde.	Anz. Qty. Qté.	Benennung	Designation	Dénomination
a	b	c						
			10	82450-02	1	Halterung	support	support
			20	N3824	2	O-Ring	o-ring	joint torique
			30	N15257	4	Zylinderschraube m. IN-6KT	allen screw	vis 6 pans creux
			40	N2623	1	Manometer	pressure gauge	manomètre
			50	N23001	1	Druckschalter	pressure switch	manostat
			60	N17133	1	Verschlußschraube	plug	bouchon
			70	N4878	1	O-Ring	o-ring	joint torique
			80	82450-03	1	Adapter	adapter	adaptateur
			90	N3683	3	Zylinderschraube m. IN-6KT	allen screw	vis 6 pans creux
			100	075330	1	Druckhalte-Rückschlagventil PN350	pressure maintaining/non return valve PN350	soupape de maintien de pression/anti-re-tour PN350
			110	N19539	4	Zylinderschraube m. IN-6KT	allen screw	vis 6 pans creux
			120	84167-01	1	Verteilerblock	outlet manifold	bloc distributeur
			130	090318	1	Flansch kpl.	flange assy.	bride cpl.
			131	90237	1	Flansch	flange	bride
			132	N19548	2	Zylinderschraube m. IN-6KT	allen screw	vis 6 pans creux
			133	N4882	1	O-Ring	o-ring	joint torique
			140	N4731	1	O-Ring	o-ring	joint torique

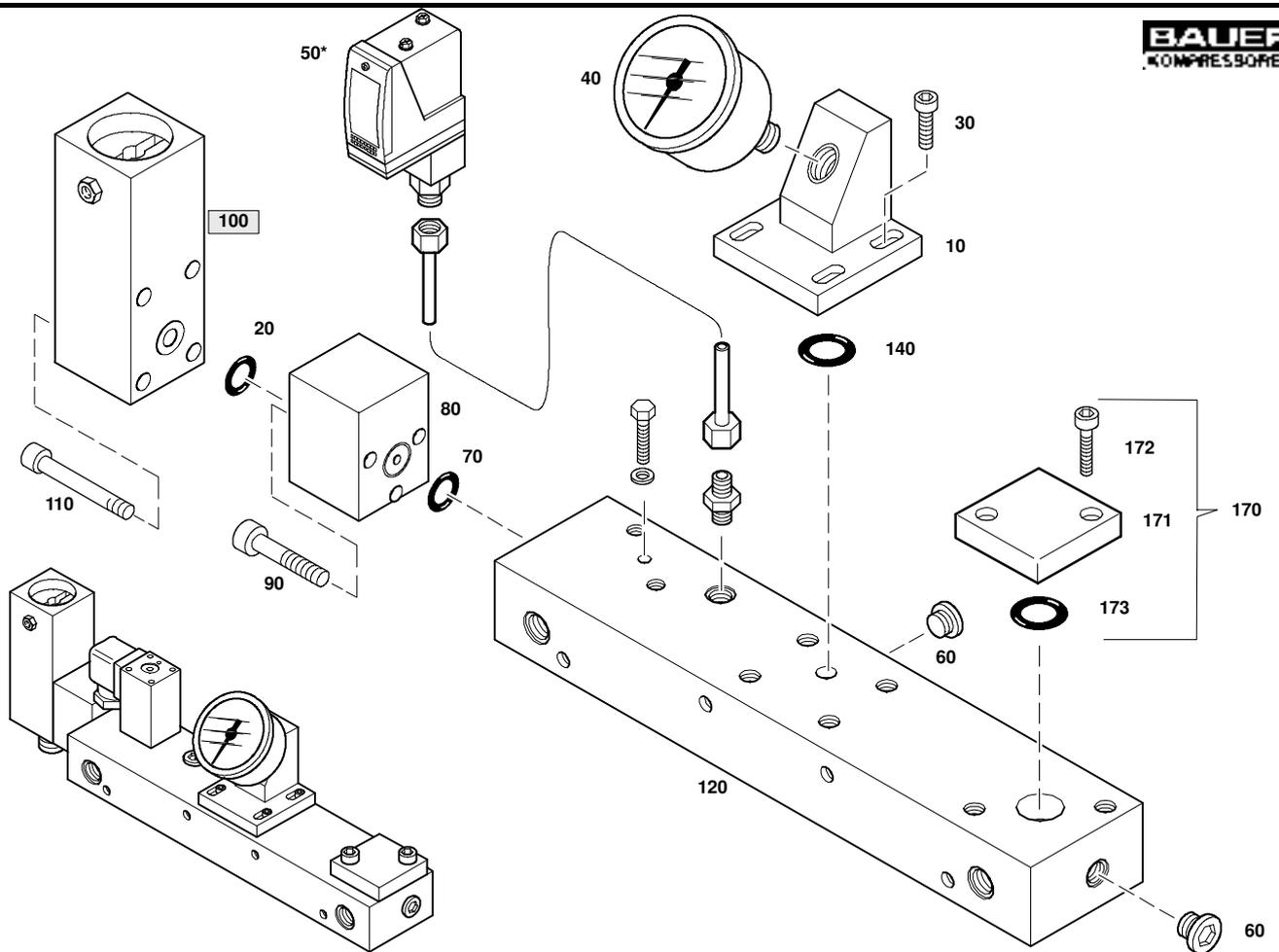

Wartungssätze
 Maintenance sets
 Kits de maintenance

Baugruppe 84167-S01
 Assembly 84167-S01
 Assemblage 84167-S01

Verteilerblock vollautomatisch kpl.
 Automatic outlet manifold assy
 Bloc de distribution automatique cpl.

D17.0- 3

Klasse/ Class/ Classe			Pos.	Bestell-Nr. Part No. No. de cde.	Anz. Qty. Qté.	Benennung	Designation	Dénomination
a	b	c						
			10	82450-02	1	Halterung	support	support
			20	N3824	1	O-Ring	o-ring	joint torique
			30	N15257	4	Zylinderschraube m. IN-6KT	allen screw	vis 6 pans creux
			40	N2623	1	Manometer	pressure gauge	manomètre
			50	N4526*	1	Druckschalter	pressure switch	manostat
			60	N17133	1	Verschlusschraube	plug	bouchon
			70	N4878	1	O-Ring	o-ring	joint torique
			80	82450-03	1	Adapter	adapter	adaptateur
			90	N3683	3	Zylinderschraube m. IN-6KT	allen screw	vis 6 pans creux
			100	075330	1	Druckhalte-Rückschlagventil PN350	pressure maintaining/non return valve PN350	soupape de maintien de pression/anti-re-tour PN350
			110	N19539	4	Zylinderschraube m. IN-6KT	allen screw	vis 6 pans creux
			120	84167-01	1	Verteilerblock	outlet manifold	bloc distributeur
			130	090318	1	Flansch kpl.	flange assy.	bride cpl.
			131	90237	1	Flansch	flange	bride
			132	N19548	2	Zylinderschraube m. IN-6KT	allen screw	vis 6 pans creux
			133	N4882	1	O-Ring	o-ring	joint torique
			140	N4731	1	O-Ring	o-ring	joint torique

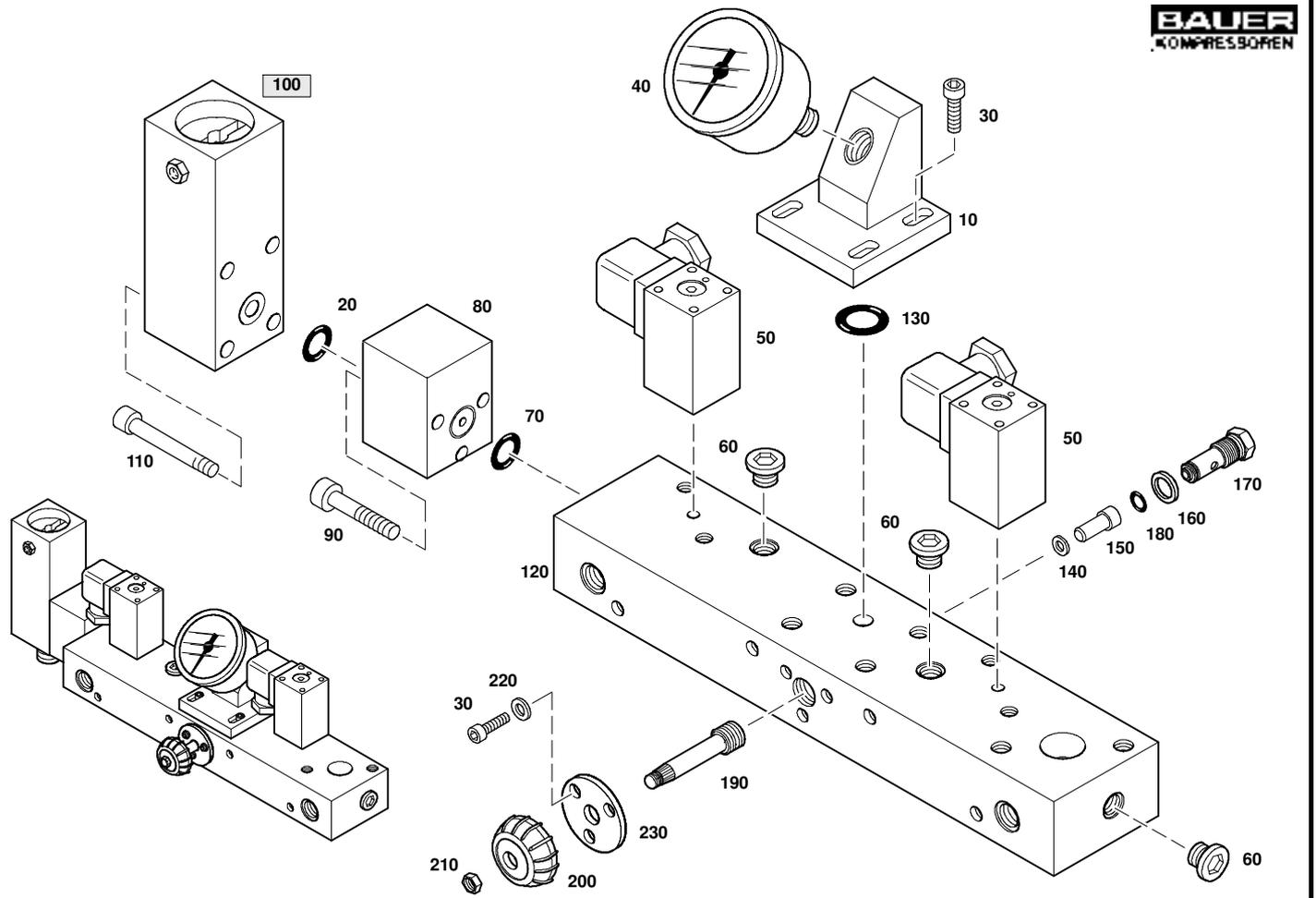

Wartungssätze
 Maintenance sets
 Kits de maintenance

Baugruppe 82450
 Assembly 82450
 Assemblage 82450

Verteilerblock halbautomatisch kpl.
 Semi-automatic outlet manifold assy
 Bloc de distribution semi-automatique cpl.

D17.0- 4

Klasse/ Class/ Classe			Pos.	Bestell-Nr. Part No. No. de cde.	Anz. Qty. Qté.	Benennung	Designation	Dénomination
a	b	c						
			10	82450-02	1	Halterung	support	support
			20	N3824	1	O-Ring	o-ring	joint torique
			30	N15257	7	Zylinderschraube m. IN-6KT	allen screw	vis 6 pans creux
			40	N2623	1	Manometer	pressure gauge	manomètre
			50	N23001	2	Druckschalter	pressure switch	manostat
			60	N17133	3	Verschlußschraube	plug	bouchon
			70	N4878	1	O-Ring	o-ring	joint torique
			80	82450-03	1	Adapter	adapter	adaptateur
			90	N3683	3	Zylinderschraube m. IN-6KT	allen screw	vis 6 pans creux
			100	075330	1	Druckhalte-Rückschlagventil PN350	pressure maintaining/non return valve PN350	soupape de maintien de pression/anti-retour PN350
			110	N19539	4	Zylinderschraube m. IN-6KT	allen screw	vis 6 pans creux
			120	82450-01	1	Verteilerblock	outlet manifold	bloc distributeur
			130	N4731	1	O-Ring	o-ring	joint torique
X			140	N17080	1	Dichtung	gasket	joint
X			150	074860	1	Dichtsitz kpl.	snug fit	siège d'étanchéité
X			160	N4602	1	USIT-Ring	usit-ring	joint usit
			170	82588	1	Ventilsitz	valve seat	siège de soupape
X			180	N16591	1	O-Ring	o-ring	joint torique
			190	82997	1	Spindel	spindle	axe
			200	N1865	1	Handrad	handwheel	molette
			210	N2488	1	Selbstsichernde Mutter	hexagon nut self-locking	écrou hexagonal auto-freinant
			220	N2949	3	Scheibe	washer	rondelle
			230	82450-04	1	Abdeckung	cover	couvercle

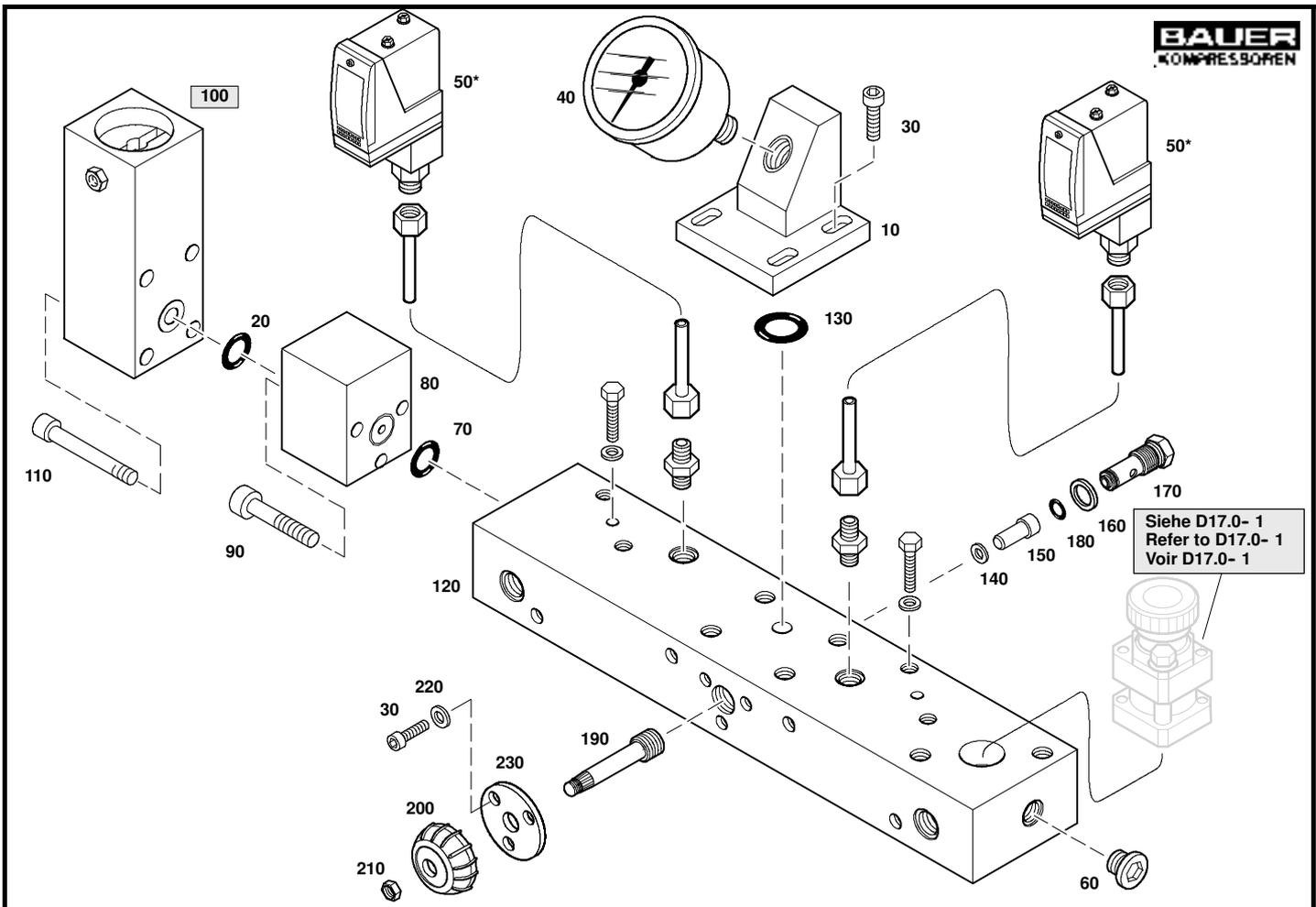

Wartungssätze
Maintenance sets
Kits de maintenance

Baugruppe 82450-S01
Assembly 82450-S01
Assemblage 82450-S01

Verteilerblock vollautomatisch kpl.
Automatic outlet manifold assy
Bloc de distribution automatique cpl.

D17.0- 5

Klasse/ Class/ Classe			Pos.	Bestell-Nr. Part No. No. de cde.	Anz. Qty. Qté.	Benennung	Designation	Dénomination
a	b	c						
			10	82450-02	1	Halterung	support	support
			20	N3824	1	O-Ring	o-ring	joint torique
			30	N15257	7	Zylinderschraube m. IN-6KT	allen screw	vis 6 pans creux
			40	N2623	1	Manometer	pressure gauge	manomètre
			50	N4526*	2	Druckschalter	pressure switch	manostat
			60	N17133	3	Verschlußschraube	plug	bouchon
			70	N4878	1	O-Ring	o-ring	joint torique
			80	82450-03	1	Adapter	adapter	adaptateur
			90	N3683	3	Zylinderschraube m. IN-6KT	allen screw	vis 6 pans creux
			100	075330	1	Druckhalte-Rückschlagventil PN350	pressure maintaining/non return valve PN350	soupape de maintien de pression/anti-retour PN350
			110	N19539	4	Zylinderschraube m. IN-6KT	allen screw	vis 6 pans creux
			120	82450-01	1	Verteilerblock	outlet manifold	bloc distributeur
			130	N4731	1	O-Ring	o-ring	joint torique
X			140	N17080	1	Dichtung	gasket	joint
X			150	074860	1	Dichtsitz kpl.	snug fit	siège d'étanchéité
X			160	N4602	1	USIT-Ring	usit-ring	joint usit
			170	82588	1	Ventilsitz	valve seat	siège de soupape
X			180	N16591	1	O-Ring	o-ring	joint torique
			190	82997	1	Spindel	spindle	axe
			200	N1865	1	Handrad	handwheel	molette
			210	N2488	1	Selbstsichernde Mutter	hexagon nut self-locking	écrou hexagonal auto-freinant
			220	N2949	3	Scheibe	washer	rondelle
			230	82450-04	1	Abdeckung	cover	couvercle

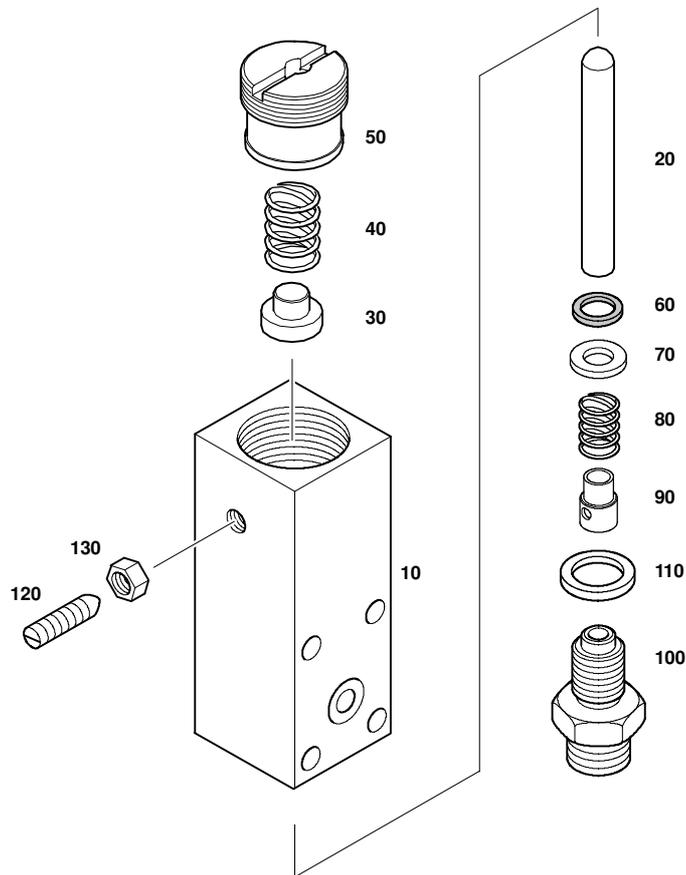
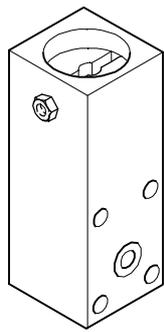

Wartungssätze
 Maintenance sets
 Kits de maintenance

Baugruppe 075330
 Assembly 075330
 Assemblage 075330

Druckhalte-Rückschlagventil
 Pressure maintaining/non-return valve
 Soupape de maintien de pression/anti-retour

D17.0- 6

Klasse/ Class/ Classe			Pos.	Bestell-Nr. Part No. No. de cde.	Anz. Qty. Qté.	Benennung	Designation	Dénomination
a	b	c						
			10	75309	1	Ventilkörper	valve body	corps de soupape
			20	77245	1	Zylinderstift	cylinder stud	tige cylindrique
			30	57762	1	Aufnahme	spring seat	siège de ressort
			40	2623	1	Druckfeder	spring	ressort de pression
			50	57935	1	Einstellschraube	adjusting screw	vis d'ajustage
			60	N17080	1	Dichtung	gasket	joint
			70	90965	1	Scheibe	disc	rondelle
			80	N23206	1	Druckfeder	spring	ressort
			90	90968	1	Ventilkolben	valve piston	piston
			100	90966	1	Ventilsitz	valve seat	valve seat
			110	N4602	1	USIT-Ring	usit-ring	joint usit
			120	N4465	1	Gewindestift m. Schlitz u. Spitze	set screw	goujon fileté
			130	N3837	1	Selbstsichernde Mutter	hexagon nut self-locking	écrou hexagonal auto-freinant

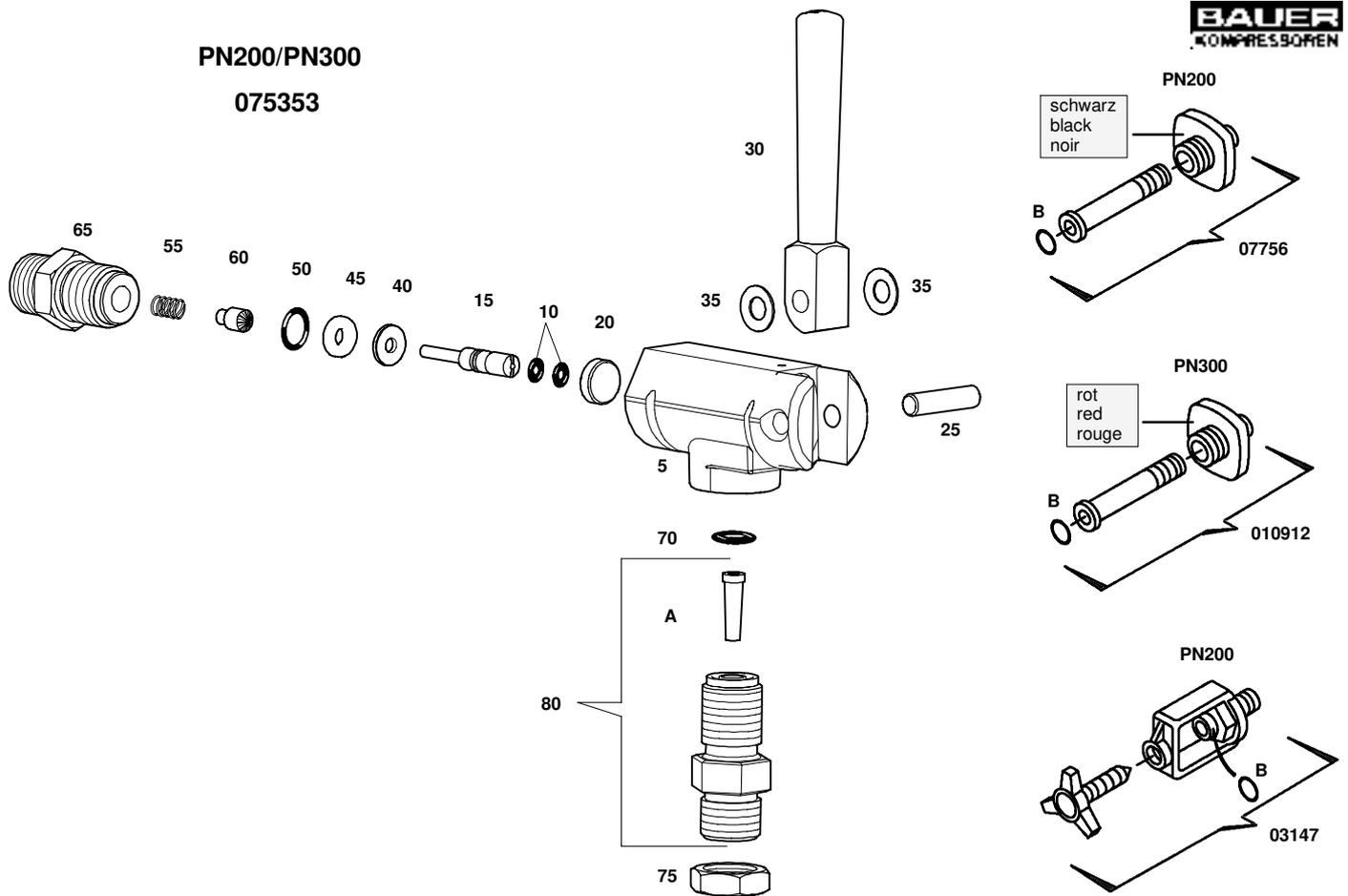
PN200/PN300
075353

Wartungssätze
Maintenance kits
Kits d'entretien
Baugruppe 075353
Assembly 075353
Assemblage 075353

Füllventil
Filling valve
Vanne de remplissage
D17.0- 7

Klasse/ Class/ Classe			Pos.	Bestell-Nr. Part No. No. de cde.	Anz. Qty. Qté.	Benennung	Designation	Dénomination
a	b	c						
			5		1	Ventilkörper	valve body	corps de vanne
X			10	N3558	2	O-Ring	o-ring	joint torique
X			15	11318	1	Kolben	valve piston	piston
			20	13718-S01	1	Ventiplatte	valve plate	plaque
			25	N16258	1	Zylinderstift	pin	axe
			30	11322	1	Hebel	handle	levier
			35	N3357	2	Tellerfeder	spring washer	rondelle-ressort
			40	57695	1	Stützscheibe	supporting ring	rondelle d'appui
X			45	13622	1	Ventilsitz	valve seat	siège de vanne
X			50	N3331	1	O-Ring	o-ring	joint torique
			55	7071	1	Druckfeder	spring	ressort
X			60	57068	1	Dichtkegel	valve cone	cône de soupape
			65	75311	1	Sechskant	hexagon	écrou 6 pans
X			70	N3355	1	O-Ring	o-ring	joint torique
			75	64279	1	Kontermutter	lock nut	contre-écrou
			80	076421	1	Doppelnippel	double nipple	manchon fileté double

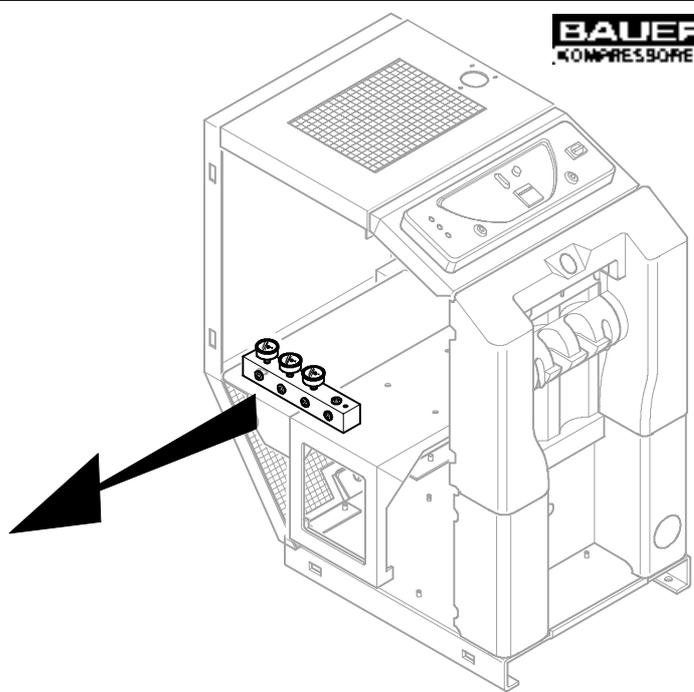
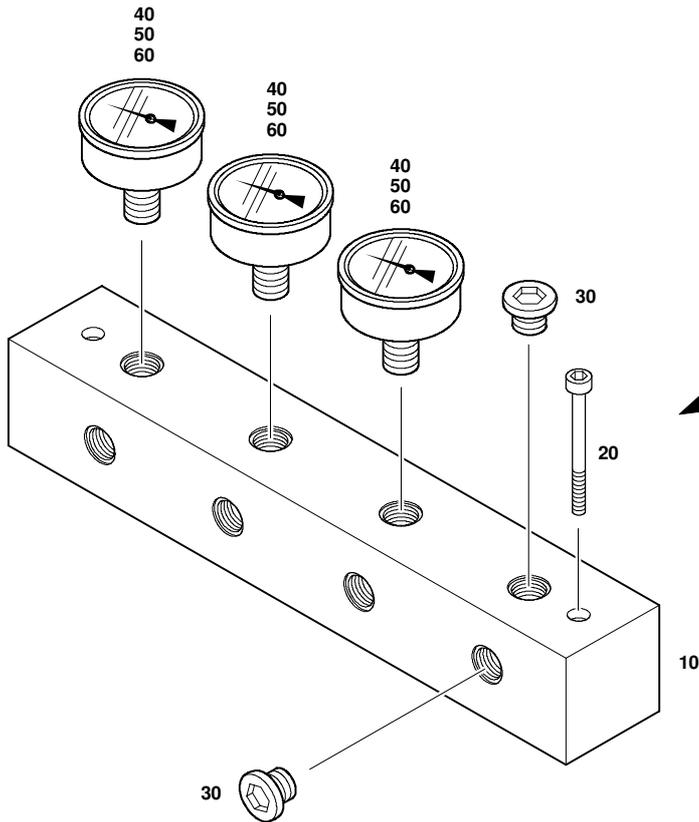
X		A	76386	1	Sinterfilter	sintered filter	filtre en métal fritté
X		B	N638	1	O-Ring	o-ring	joint torique



Wartungssätze
 Maintenance sets
 Kits de maintenance

Baugruppe 84196 Anschlußleiste
 Assembly 84196 Connecting manifold
 Assemblage 84196 Rampe de distribution

D17.0- 8

Klasse/ Class/ Classe			Pos.	Bestell-Nr. Part No. No. de cde.	Anz. Qty. Qté.	Benennung	Designation	Dénomination
a	b	c						
			10	80076	1	Leiste	manifold	rampe
			20	N19555	2	Zylinderschraube m. IN-6KT	allen screw	vis 6 pans creux
			30	N16394	12	Verschlußschraube	plug	bouchon
			40	N25981	1	Zwischendruck-Manometer, 0-100 bar	intermediate pressure manometer, 0-100 bar	manomètre de pression intermédiaire, 0-100 bar
			50	N22331	1	Zwischendruck-Manometer, 0-16 bar	intermediate pressure manometer, 0-16 bar	manomètre de pression intermédiaire, 0-16 bar
			60	N22331	1	Öl-druck-Manometer, 0-16 bar	oil pressure manometer, 0-16 bar	manomètre de pression d'huile, 0-16 bar

Ersatzteilliste	E28.0	Rahmen Mini-Verticus III
Spare parts catalogue	E28.0	Frame Mini-Verticus III
Liste des pièces	E28.0	Cadre Mini-Verticus III

Baugruppe	Assembly	Assemblage	Bild/Fig.
Rahmen	Frame	Châssis	E28.0- 1
Verkleidung	Facing	Habillage	E28.0- 2
Ölablaß	Oil drain assy.	Vidange d'huile	E28.0- 3

Änder.-Nr. Change no. No. de change	Datum Date	Änderung	Change	Changement
0	01.10.2006	Grundausgabe	Basic edition	Edition de base

Wichtige Hinweise für Teilebestellung:

Bestell-Nr., die mit der Ziffer 0 beginnen, bezeichnen Baugruppen, die komplett geliefert werden. Teile ohne Bestell-Nr. sind nur zur Information für die Montage aufgeführt. Sie sind nicht als Ersatzteil erhältlich. Bei Ersatzteilbestellungen erwarten Sie unsere richtige Lieferung; deshalb benötigen wir von Ihnen folgende Angaben (siehe unten gezeigtes Typenschild):

1. Modellbezeichnung, Fabrik-Nr. sowie Fertigungsstand von Anlage/Block
2. Stückzahlen
3. Benennung und Best.-Nr. des gewünschten Teils

Bestell-Beispiel:

Für Kompressorblock ...
Fabrik-Nr. 524-0528/1/2 drei Dichtungen
8263-090

Important notes for spare parts orders:

Part nos. beginning with digit 0 indicate parts available as complete assemblies. Parts without part no. are indicated for assembly reference, only. These parts are not available as single parts. When placing an order for spare parts, please give the following items so as to ensure our correct delivery (see identification plate shown below):

1. Model, serial no. as well as design standard of unit/block
2. Quantity required
3. Name and part no.

Example for order:

For compressor block ...
serial no. 524-0528/1/2, three gaskets
8263-090

Avis important pour la commande de pièces:

Les nos. de commande commençant par le chiffre 0 indiquent les pièces livrées au complet. Les pièces sans no. de commande sont indiquées uniquement pour information de montage. Elles ne sont pas livrées individuellement. Pour que la livraison de pièces de rechange corresponde à la commande, veuillez bien nous fournir les données suivantes (voir plaque d'identité ci-dessous):

1. Modèle, no. de série et standard de construction de bloc compresseur/groupe
2. Quantité désirée
3. Dénomination et no. de commande de la pièce désirée

Exemple de commande:

Pour bloc compresseur ...
no. de série 524-0528/1/2, trois joints no. de cde. 8263-090



Wartungssätze

- a = Wartungssatz 500 h
- b = Wartungssatz 1000 h
- c = Wartungssatz 2000 h



Maintenance kit

- a = Maintenance kit 500 h
- b = Maintenance kit 1000 h
- c = Maintenance kit 2000 h



Kits de pièces d'entretien :

- a = Kit d'entretien 500 h
- b = Kit d'entretien 1000 h
- c = Kit d'entretien 2000 h

In den Spalten sind die im entsprechenden Satz enthaltenen Teile angekreuzt. Bitte beachten, daß die höheren Sätze die untergeordneten nicht beinhalten, d.h. für eine 2000-Stunden-Wartung wird 1x Satz a, 1x Satz b und 1x Satz c benötigt.

The columns contain the parts that are included in the respective parts set. Please note that the higher graded kits do not include the lower ones, i.e. for a 2000 hours maintenance, one kit a, one kit b plus one kit c are required.

Les pièces contenues dans les kits correspondants sont marquées d'une croix dans les colonnes. Veuillez observer que les kits supérieurs ne contiennent pas les kits subordonnés, c'est-à-dire pour un entretien de 2000 heures il faut avoir 1x kit a, 1x kit b et 1x kit c.

Anmerkungen zur Identifikation:

Remarks for identification:

Remarques pour l'identification:

Modell/Model/Modèle		Fabrik-Nr./Serial no./Numéro de série	
<input type="checkbox"/>		<input type="checkbox"/>	
Volumenstrom m ³ /min	<input type="checkbox"/>	Jahr Year	<input type="checkbox"/>
Free air delivery Scfm	<input type="checkbox"/>	n/min. r.p.m.	<input type="checkbox"/>
Betriebsüberdruck bar	<input type="checkbox"/>	kW	<input type="checkbox"/>
Max. working press. psig	<input type="checkbox"/>	KB 73708	<input type="checkbox"/>
		Fertigungsstand / Modification no. / No. de modification	
		Anlage/Unit/Groupe	
		Kompressorblock / Compressor block / Bloc compresseur	



ACHTUNG

Nur Schrauben und Stiftschrauben der Qualität 8.8 verwenden!



ATTENTION

Use only screws and studs in quality 8.8! This quality is equivalent to SAE J 429 d grade 5.



ATTENTION

N'utiliser que des vis et des goujons filetés de la qualité 8.8!

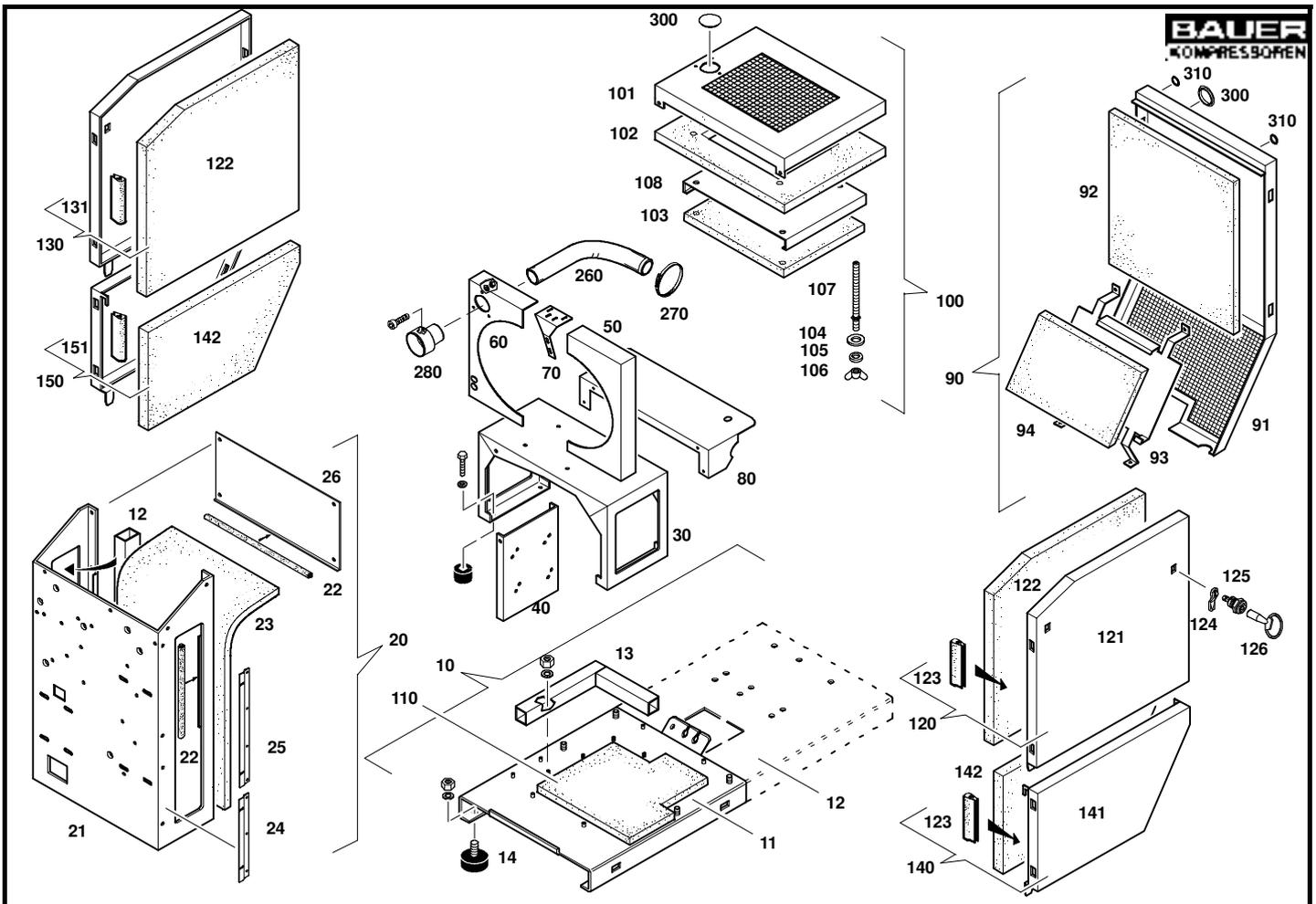

E28.0- 1

Wartungssätze
Mainenance kits
Kits d'entretien

Baugruppe 83150 **Rahmen**
Assembly 83150 **Frame**
Assemblage 83150 **Cadre**

Klasse/ Class/ Classe			Pos.	Bestell-Nr. Part No. No. de cde.	Anz. Qty. Qté.	Benennung	Designation	Dénomination
a	b	c						
			10	83921	1	Grundplatte kpl.	base plate assy	châssis cpl.
			11	81740	1	Grundplatte, kurz	base plate, short	châssis, court
			12	85801	1	Grundplatte, lang	base plate, long	châssis, long
			13	N22772	mm*	Kabelkanal	cable canal	conduite de câbles
			14	N1547	4	Schwingmetall	vibration isolator	silent-bloc
			20	82983	1	Frontblech kpl.	front plate assy	tole frontale cpl.
			21	81742	1	Frontblech	front plate	tole frontale
			22	N16046	mm*	Dichtungsprofil	profiled joint	joint d'étanchéité profilé
			23	81762-04	1	Schalldämmung	sound insulation	isolant phonique
			24	83965	2	Halterung	fitting	fixation
			25	83954	2	Halterung	fitting	fixation
			26	81742-03	1	Trennblech	separation plate	tole de séparation
			30	81741	1	Schwingrahmen	anti-vibration frame	cadre anti-vibration
			40	82377	1	Motorwippe	hinged motor plate	bascule de moteur
			50	82475-02	1	Schottwand, rechts	baffle assy, right	cloison, droite
			60	82475-01	1	Schottwand, links	baffle assy, left	cloison, gauche
			70	82475-03	1	Halterung	fitting	fixation
			80	84182	1	Trennblech	separation plate	tole de séparation
			90	83888	1	Rückblech kpl.	back assy.	façade arrière cpl.
			91	82442	1	Rückblech	back plate	tole arrière
			92	81762-03	1	Schalldämmung	sound insulation	isolant phonique
			93	82331	1	Trennblech	separation plate	tole de séparation
			94	81762-09	1	Schalldämmung	sound insulation	isolant phonique
			100	83858	1	Dach kpl.	roof assy	toit cpl.
			101	81808	1	Dach	roof	toit
			102	81762-08	1	Schalldämmung	sound insulation	isolant phonique
			103	81762-02	1	Schalldämmung	sound insulation	isolant phonique
			104	N15728	4	Scheibe	washer	rondelle
			105	N102	4	Scheibe	washer	rondelle

*

Meterware

Piece goods

Marchandise au mètre

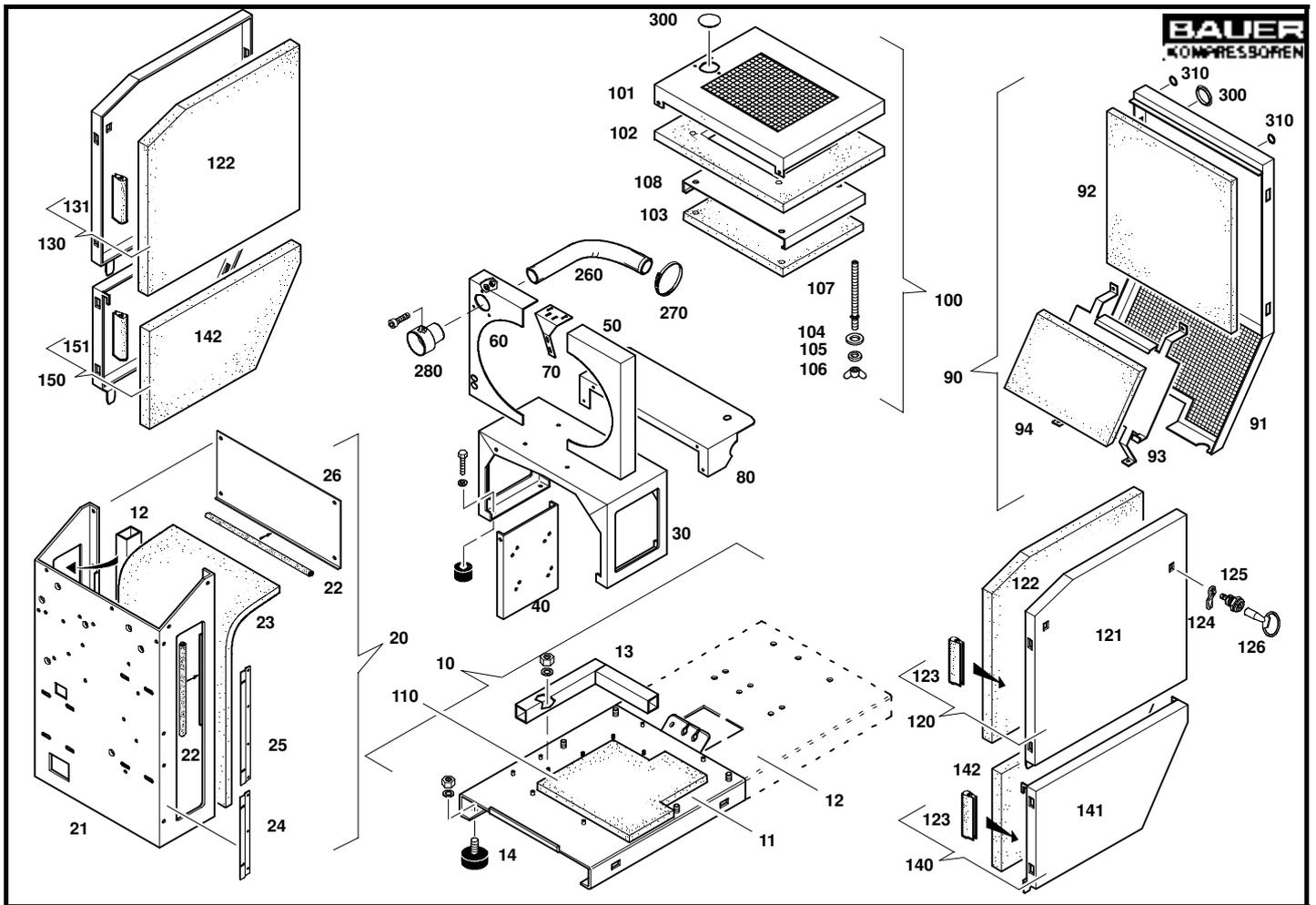

**Wartungssätze
Maintenance kits
Kits d'entretien**

Baugruppe 83150 Rahmen
Assembly 83150 Frame
Assemblage 83150 Cadre

E28.0- 1

Klasse/ Class/ Classe			Pos.	Bestell-Nr. Part No. No. de cde.	Anz. Qty. Qté.	Benennung	Designation	Dénomination
a	b	c						
			106	N28928	4	Flügelschraube	butterfly nut	écrou papillon
			107	82459	1	Halterung	fitting	fixation
			108	83330	1	Trennblech	separation plate	tole de séparation
			110	81762-10	1	Schalldämmung	sound insulation	isolant phonique
			120	84066	1	Deckel kpl., rechts	cover assy., right	porte cpl., droite
			121	84066-01	1	Deckel, rechts	cover, right	porte, droite
			122	81762-13	1	Schalldämmung	sound insulation	isolant phonique
			123	N16744	mm*	Dichtungsprofil	profiled joint	joint d'étanchéité profilé
			124	N28394	2	Zunge	tongue	languette
			125	N18970	2	Vorreiber	lock	vérou
			126	N16230	2	Schlüssel	pipe key	clef
			130	84061	1	Deckel kpl., links	cover assy., left	porte cpl., gauche
			131	84061-01	1	Deckel, links	cover, left	porte, gauche
			140	84065	1	Deckel kpl., rechts	cover assy., right	porte cpl., droite
			141	84065-01	1	Deckel, rechts	cover, right	porte, droite
			142	81762-12	1	Schalldämmung	sound insulation	isolant phonique
			150	84060	1	Deckel kpl., links	cover assy., left	porte cpl., gauche
			151	84060-01	1	Deckel, links	cover, left	porte, gauche
			260	N27481	1	Schlauch	hose	tuyau
			270	N27540	2	Schelle	hose clamp	collier
			280	82639	1	Durchführung	bulkhead	manchon
			300	N25625	1	Abdeckung, Ø64	plug, Ø64	bouchon, Ø64
			310	N23373	1	Abdeckung, Ø33	plug, Ø33	bouchon, Ø33

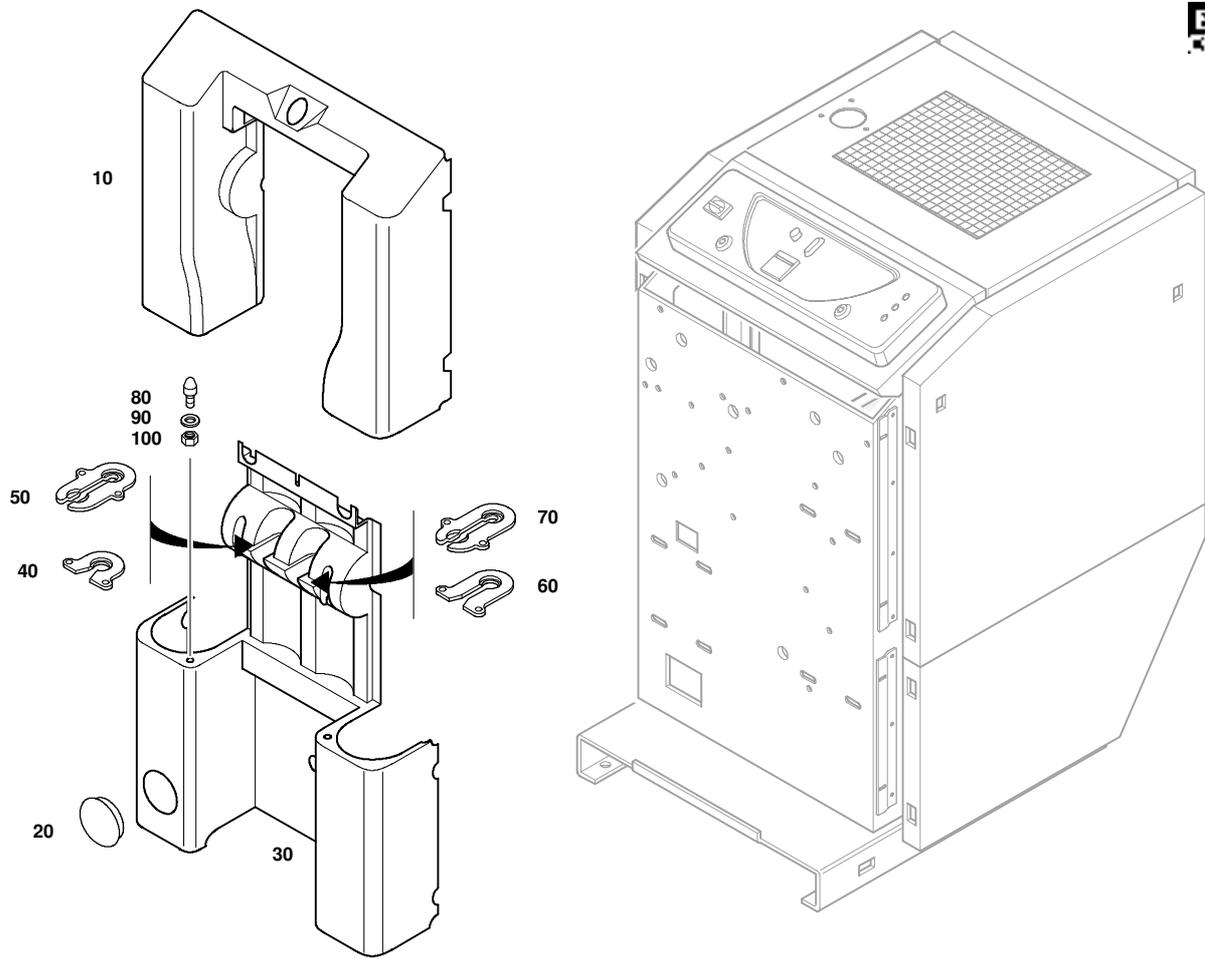

Wartungssätze
 Mainenance kits
 Kits d'entretien

Baugruppe 85293
 Assembly 85293
 Assemblage 85293

Verkleidung
 Facing
 Habillage

E28.0- 2

Klasse/ Class/ Classe			Pos.	Bestell-Nr. Part No. No. de cde.	Anz. Qty. Qté.	Benennung	Designation	Dénomination
a	b	c						
			10	85256	1	Verkleidung	front panel	façade
			20	N28503	1	Abdeckung	cover	couvercle
			30	85255	1	Verkleidung	front panel	façade
			40	83230	1	Halterung, links	fitting, left	fixation, gauche
			50	84197	1	Halterung 2fach, links	double fitting, left	fixation double, gauche
			60	83230-01	1	Halterung, rechts	fitting, right	fixation, droite
			70	84199	1	Halterung 2fach, rechts	double fitting, right	fixation double, droite
			80	83851	2	Bolzen	screwing pin	boulon
			90	N102	2	Scheibe	washer	rondelle
			100	N17459	2	Sechskantmutter	hexagon nut self-locking	écrou hexagonal auto-frein.

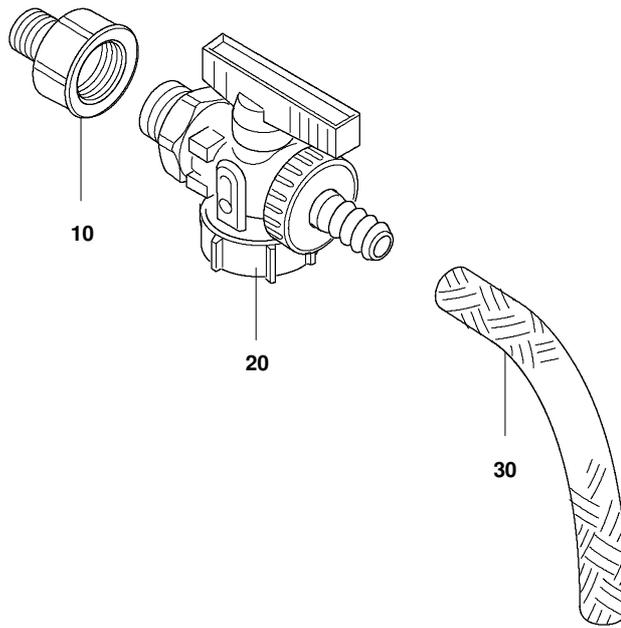

Wartungssätze
Maintenance kits
Kits d'entretien

Baugruppe 78642-02
Assembly 78642-02
Assemblage 78642-02

Ölablaß kpl.
Oil drain assy.
Vidange d'huile cpl.

E28.0- 3

Klasse/ Class/ Classe			Pos.	Bestell-Nr. Part No. No. de cde.	Anz. Qty. Qté.	Benennung	Designation	Dénomination
a	b	c						
			10	N2375	1	Reduzierstutzen	reducer	réducteur
			20	N25638	1	Kugelhahn	shutoff valve	robinet
			30	N19939	m	Schlauch	hose	tuyau

Ersatzteilliste **F16.0 Motor und Zubehör** **Mini-Verticus III**
Spare parts catalogue **F16.0 Motor and accessories** **Mini-Verticus III**
Liste des pièces **F16.0 Moteur et accessoires** **Mini-Verticus III**

<u>Baugruppe</u>	<u>Assembly</u>	<u>Assemblage</u>	<u>Bild/Fig.</u>
Motor und Zubehör, 4 kW	Motor and accessories, 4 kW . . .	Moteur d'entraînement et accessoires, 4 kW . .	F16.0- 1
Motor und Zubehör, 5,5 kW . . .	Motor and accessories, 5,5 kW . .	Moteur d'entraînement et accessoires, 5,5 kW . .	F16.0- 2

Änder.-Nr. Change no. No. de change	Datum Date	Änderung	Change	Changement
0	01.10.2006	Grundaussgabe	Basic edition	Edition de base
4				
5				
5				

Wichtige Hinweise für Teilebestellung:

Bestell-Nr., die mit der Ziffer 0 beginnen, bezeichnen Baugruppen, die komplett geliefert werden. Teile ohne Bestell-Nr. sind nur zur Information für die Montage aufgeführt. Sie sind nicht als Ersatzteil erhältlich. Bei Ersatzteilbestellungen erwarten Sie unsere richtige Lieferung; deshalb benötigen wir von Ihnen folgende Angaben (siehe unten gezeigtes Typenschild):

1. Modellbezeichnung, Fabrik-Nr. sowie Fertigungsstand von Anlage/Block
2. Stückzahlen
3. Benennung und Best.-Nr. des gewünschten Teils

Bestell-Beispiel:

Für Kompressorblock ...
Fabrik-Nr. 524-0528/1/2 drei Dichtungen
8263-090

Important notes for spare parts orders:

Part nos. beginning with digit 0 indicate parts available as complete assemblies. Parts without part no. are indicated for assembly reference, only. These parts are not available as single parts. When placing an order for spare parts, please give the following items so as to ensure our correct delivery (see identification plate shown below):

1. Model, serial no. as well as design standard of unit/block
2. Quantity required
3. Name and part no.

Example for order:

For compressor block ...
serial no. 524-0528/1/2, three gaskets
8263-090

Avis important pour la commande de pièces:

Les nos. de commande commençant par le chiffre 0 indiquent les pièces livrées au complet. Les pièces sans no. de commande sont indiquées uniquement pour information de montage. Elles ne sont pas livrées individuellement. Pour que la livraison de pièces de rechange corresponde à la commande, veuillez bien nous fournir les données suivantes (voir plaque d'identité ci-dessous):

1. Modèle, no. de série et standard de construction de bloc compresseur/groupe
2. Quantité désirée
3. Dénomination et no. de commande de la pièce désirée

Exemple de commande:

Pour bloc compresseur ...
no. de série 524-0528/1/2, trois joints no. de cde. 8263-090



Wartungssätze

- a =Wartungssatz 500 h
- b =Wartungssatz 1000 h
- c =Wartungssatz 2000 h



Maintenance kit

- a = Maintenance kit 500 h
- b = Maintenance kit 1000 h
- c = Maintenance kit 2000 h



Kits de pièces d'entretien :

- a = Kit d'entretien 500 h
- b = Kit d'entretien 1000 h
- c = Kit d'entretien 2000 h

In den Spalten sind die im entsprechenden Satz enthaltenen Teile angekreuzt. Bitte beachten, daß die höheren Sätze die untergeordneten nicht beinhalten, d.h. für eine 2000-Stunden-Wartung wird 1x Satz a, 1x Satz b und 1x Satz c benötigt.

The columns contain the parts that are included in the respective parts set. Please note that the higher graded kits do not include the lower ones, i.e. for a 2000 hours maintenance, one kit a, one kit b plus one kit c are required.

Les pièces contenues dans les kits correspondants sont marquées d'une croix dans les colonnes. Veuillez observer que les kits supérieurs ne contiennent pas les kits subordonnés, c'est-à-dire pour un entretien de 2000 heures il faut avoir 1x kit a, 1x kit b et 1x kit c.

Anmerkungen zur Identifikation:

Remarks for identification:

Remarques pour l'identification:

Modell/Model/Modèle		Fabrik-Nr./Serial no./Numéro de série	
<input type="text"/>		<input type="text"/>	
<input type="checkbox"/>	<input type="checkbox"/>	Jahr	<input type="text"/>
<input type="checkbox"/>	<input type="checkbox"/>	Year	<input type="text"/>
Volumenstrom m ³ /min	<input type="text"/>	n/min.	<input type="text"/>
Free air delivery Scfm	<input type="text"/>	r.p.m.	<input type="text"/>
Betriebsüberdruck bar	<input type="text"/>	kW	<input type="text"/>
Max. working press. psig	<input type="text"/>	KB 73708	<input type="text"/>
		Fertigungsstand / Modification no. / No. de modification	
		Anlage/Unit/Groupe	
		Kompressorblock/ Compressor block/ Bloc compresseur	



ACHTUNG

Nur Schrauben und Stiftschrauben der Qualität 8.8 verwenden!



ATTENTION

Use only screws and studs in quality 8.8! This quality is equivalent to SAE J 429 d grade 5.



ATTENTION

N'utiliser que des vis et des goujons filetés de la qualité 8.8!

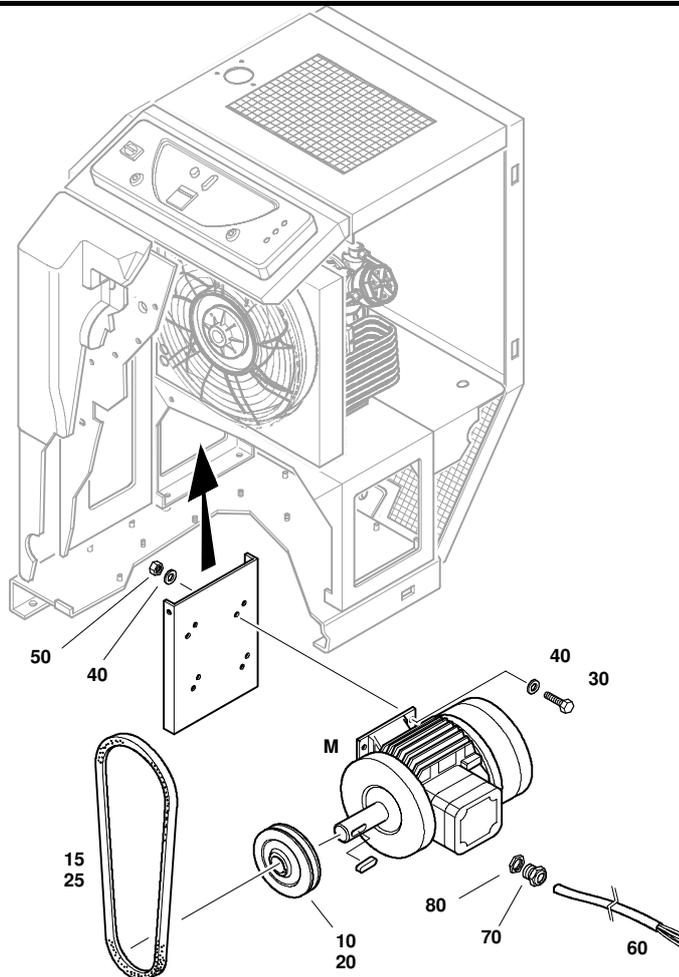
F16.0- 1

**Wartungssätze
 Maintenance kits
 Kits d'entretien**
**Baugruppe 83145 Motor und Zubehör, 4 kW
 Assembly 83145 Motor and accessories, 4 kW
 Assemblage 83145 Moteur et accessoires, 4 kW**

Klasse/ Class/ Classe			Pos.	Bestell-Nr. Part No. No. de cde.	Anz. Qty. Qté.	Benennung	Designation	Dénomination
a	b	c						
			M	N3390	1	Drehstrom-Motor 4 kW, 400 V, 2815 min ⁻¹ 50Hz: 380-415 V 60 Hz: 400-480 V	three-phase motor 4 kW, 400 V, 2815 min ⁻¹ 50Hz: 380-415 V, 50Hz 60 Hz: 400-480 V, 60 Hz	moteur tri-phasé 4 kW, 400 V, 2815 min ⁻¹ 50Hz: 380-415 V, 50Hz 60 Hz: 400-480 V, 60 Hz
			M	N16727	1	Drehstrom-Motor 4 kW, 220 V, 2815 min ⁻¹ 50Hz: 220-240 V, 380-415 V 60 Hz: 220-280 V, 380-480 V	Drehstrom-Motor 4 kW, 220 V, 2815 min ⁻¹ 50Hz: 220-240 V, 380-415 V 60 Hz: 220-280 V, 380-480 V	Drehstrom-Motor 4 kW, 220 V, 2815 min ⁻¹ 50Hz: 220-240 V, 380-415 V 60 Hz: 220-280 V, 380-480 V

			10	N18494	1	Keilriemenscheibe 50 Hz, dw190	v-belt pulley 50 Hz, dw190	poulie à gorge 50 Hz, dw190
	X		15	N26801	1	Keilriemen, Lw2000	v-belt, Lw2000	courroie trapézoïdale, Lw2000
			20	N18483	1	Keilriemenscheibe 60 Hz, dw160	v-belt pulley 60 Hz, dw160	poulie à gorge 60 Hz, dwdw160118
	X		25	N2599	1	Keilriemen, Lw1982	v-belt, Lw1982	courroie trapézoïdale, Lw1982
			30	N19506	8	Sechskantschraube	hex. screw	vis hex.
			40	N58	16	Scheibe	washer	rondelle
			50	N370	8	Selbstsichernde Mutter	hexagon nut self-locking	écrou hexagonal auto-fr.
			60	N24478*	m	Steuerleitung	power cable	câble électrique
			70	N3100	1	Kabelverschraubung	grommet	raccord
			80	N3103	1	Gegenmutter	counternut	contre-écrou

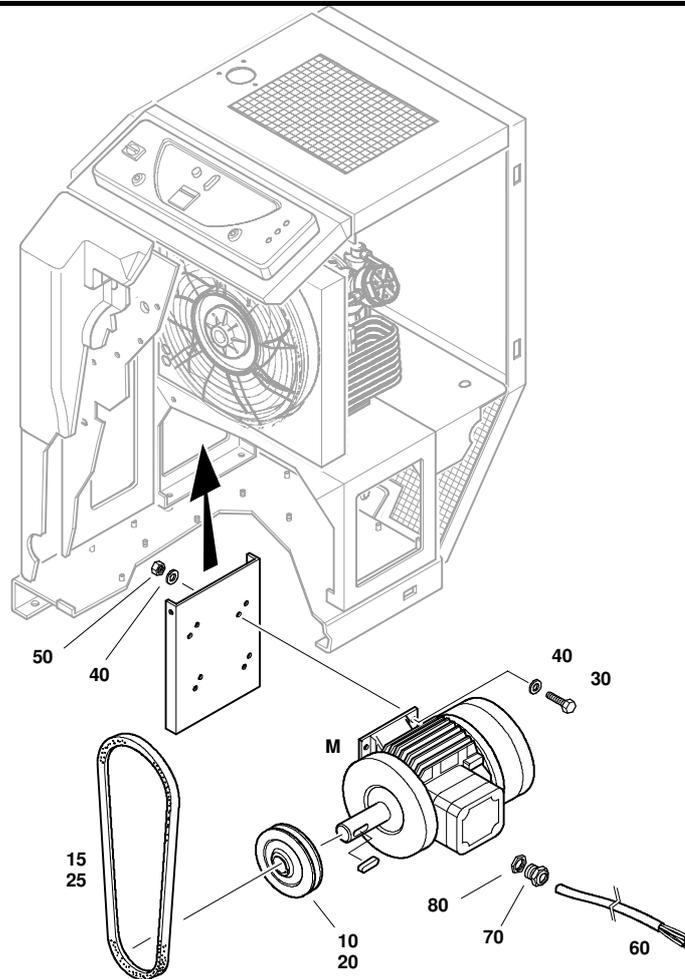
Wartungssätze
Maintenance kits
Kits d'entretien
Baugruppe 83146 Motor und Zubehör, 5,5 kW
Assembly 83146 Motor and accessories, 5,5 kW
Assemblage 83146 Moteur et accessoires, 5,5 kW
F16.0- 2

Klasse/ Class/ Classe			Pos.	Bestell-Nr. Part No. No. de cde.	Anz. Qty. Qté.	Benennung	Designation	Dénomination
a	b	c						
			M	N21717	1	Drehstrom-Motor 5,5 kW, 400 V, 2910 min ⁻¹ 50Hz: 380-415 V 60 Hz: 380-480 V	three-phase motor 5,5 kW, 400 V, 2910 min ⁻¹ 50Hz: 380-415 V, 50Hz 60 Hz: 380-480 V, 60 Hz	moteur tri-phasé 5,5 kW, 400 V, 2910 min ⁻¹ 50Hz: 380-415 V, 50Hz 60 Hz: 380-480 V, 60 Hz
			M	N17091	1	Drehstrom-Motor 5,5 kW, 220 V, 2910 min ⁻¹ 50Hz: 220-240 V, 380-415 V 60 Hz: 220-280 V, 380-480 V	Drehstrom-Motor 5,5 kW, 220 V, 2910 min ⁻¹ 50Hz: 220-240 V, 380-415 V 60 Hz: 220-280 V, 380-480 V	Drehstrom-Motor 5,5 kW, 220 V, 2910 min ⁻¹ 50Hz: 220-240 V, 380-415 V 60 Hz: 220-280 V, 380-480 V

				10	N17851	1	Keilriemenscheibe 50 Hz, dw224	v-belt pulley 50 Hz, dw224	poulie à gorge 50 Hz, dw224
	X			15	N4771	1	Keilriemen, Lw2057	v-belt, Lw2057	courroie trapézoïdale, Lw2057
				20	N17850	1	Keilriemenscheibe 60 Hz, dw180	v-belt pulley 60 Hz, dw180	poulie à gorge 60 Hz, dw180
	X			25	N26801	1	Keilriemen, Lw2000	v-belt, Lw2000	courroie trapézoïdale, Lw2000
				30	N19506	8	Sechskantschraube	hex. screw	vis hex.
				40	N58	16	Scheibe	washer	rondelle
				50	N370	8	Selbstsichernde Mutter	hexagon nut self-locking	écrou hexagonal auto-fr.
				60	N24478*	m	Steuerleitung	power cable	câble électrique
				70	N3100	1	Kabelverschraubung	grommet	raccord
				80	N3103	1	Gegenmutter	counternut	contre-écrou

Ersatzteilliste	G68.0	Kompressorsteuerung	Mini-Verticus III
Spare parts catalogue	G68.0	Compressor control system	Mini-Verticus III
Listes des pièces	G68.0	Commande électrique	Mini-Verticus III

Baugruppe	Assembly	Assemblage	Bild/Fig.
5.5 kW, 380 - 440 V; 4 kW, 220 VAC			
Kompressorsteuerung	Compressor control system	Commande électrique	G68.0- 1
4 kW, 380 - 440 V			
Kompressorsteuerung	Compressor control system	Commande électrique	G68.0- 2
3 kW, 380 - 440 V			
Kompressorsteuerung	Compressor control system	Commande électrique	G68.0- 3
3 kW, 220 V			
Kompressorsteuerung	Compressor control system	Commande électrique	G68.0- 4
Öldrucküberwachung	Oil pressure monitoring	Surveillance de la pression d'huile	G68.0- 5

Änder.-Nr. Change no. No. de change	Datum Date	Änderung	Change	Changement
0	01.10.2006	Grundausgabe	Basic edition	Edition de base

Wichtige Hinweise für Teilebestellung:

Bestell-Nr., die mit der Ziffer 0 beginnen, bezeichnen Baugruppen, die komplett geliefert werden. Teile ohne Bestell-Nr. sind nur zur Information für die Montage aufgeführt. Sie sind nicht als Ersatzteil erhältlich. Bei Ersatzteilbestellungen erwarten Sie unsere richtige Lieferung; deshalb benötigen wir von Ihnen folgende Angaben (siehe unten gezeigtes Typenschild):

1. Modellbezeichnung, Fabrik-Nr. sowie Fertigungsstand von Anlage/Block
2. Stückzahlen
3. Benennung und Best.-Nr. des gewünschten Teils

Bestell-Beispiel:

Für Kompressorblock ...
Fabrik-Nr. 524-0528/1/2 drei Dichtungen
8263-090

Important notes for spare parts orders:

Part nos. beginning with digit 0 indicate parts available as complete assemblies. Parts without part no. are indicated for assembly reference, only. These parts are not available as single parts. When placing an order for spare parts, please give the following items so as to ensure our correct delivery (see identification plate shown below):

1. Model, serial no. as well as design standard of unit/block
2. Quantity required
3. Name and part no.

Example for order:

For compressor block ...
serial no. 524-0528/1/2, three gaskets
8263-090

Avis important pour la commande de pièces:

Les nos. de commande commençant par le chiffre 0 indiquent les pièces livrées au complet. Les pièces sans no. de commande sont indiquées uniquement pour information de montage. Elles ne sont pas livrées individuellement. Pour que la livraison de pièces de rechange corresponde à la commande, veuillez bien nous fournir les données suivantes (voir plaque d'identité ci-dessous):

1. Modèle, no. de série et standard de construction de bloc compresseur/groupe
2. Quantité désirée
3. Dénomination et no. de commande de la pièce désirée

Exemple de commande:

Pour bloc compresseur ...
no. de série 524-0528/1/2, trois joints no. de cde. 8263-090



Wartungssätze

- a =Wartungssatz 500 h
- b =Wartungssatz 1000 h
- c =Wartungssatz 2000 h



Maintenance kit

- a = Maintenance kit 500 h
- b = Maintenance kit 1000 h
- c = Maintenance kit 2000 h



Kits de pièces d'entretien :

- a = Kit d'entretien 500 h
- b = Kit d'entretien 1000 h
- c = Kit d'entretien 2000 h

In den Spalten sind die im entsprechenden Satz enthaltenen Teile angekreuzt. Bitte beachten, daß die höheren Sätze die untergeordneten nicht beinhalten, d.h. für eine 2000-Stunden-Wartung wird 1x Satz a, 1x Satz b und 1x Satz c benötigt.

The columns contain the parts that are included in the respective parts set. Please note that the higher graded kits do not include the lower ones, i.e. for a 2000 hours maintenance, one kit a, one kit b plus one kit c are required.

Les pièces contenues dans les kits correspondants sont marquées d'une croix dans les colonnes. Veuillez observer que les kits supérieurs ne contiennent pas les kits subordonnés, c'est-à-dire pour un entretien de 2000 heures il faut avoir 1x kit a, 1x kit b et 1x kit c.

Anmerkungen zur Identifikation:

Remarks for identification:

Remarques pour l'identification:

Modell/Model/Modèle		Fabrik-Nr./Serial no./Numéro de série	
<input type="text"/>		<input type="text"/>	
<input type="checkbox"/>	<input type="checkbox"/>	Jahr/Year	<input type="text"/>
<input type="checkbox"/>	<input type="checkbox"/>	n/min./r.p.m.	<input type="text"/>
Volumenstrom m ³ /min	<input type="text"/>	kW	<input type="text"/>
Free air delivery Scfm	<input type="text"/>	KB 73708	<input type="text"/>
Betriebsüberdruck bar	<input type="text"/>	Fertigungsstand / Modification no. / No. de modification	
Max. working press. psig	<input type="text"/>	Anlage/Unit/Groupe	
		Kompressorblock/ Compressor block/ Bloc compresseur	



ACHTUNG

Nur Schrauben und Stiftschrauben der Qualität 8.8 verwenden!



ATTENTION

Use only screws and studs in quality 8.8! This quality is equivalent to SAE J 429 d grade 5.



ATTENTION

N'utiliser que des vis et des goujons filetés de la qualité 8.8!

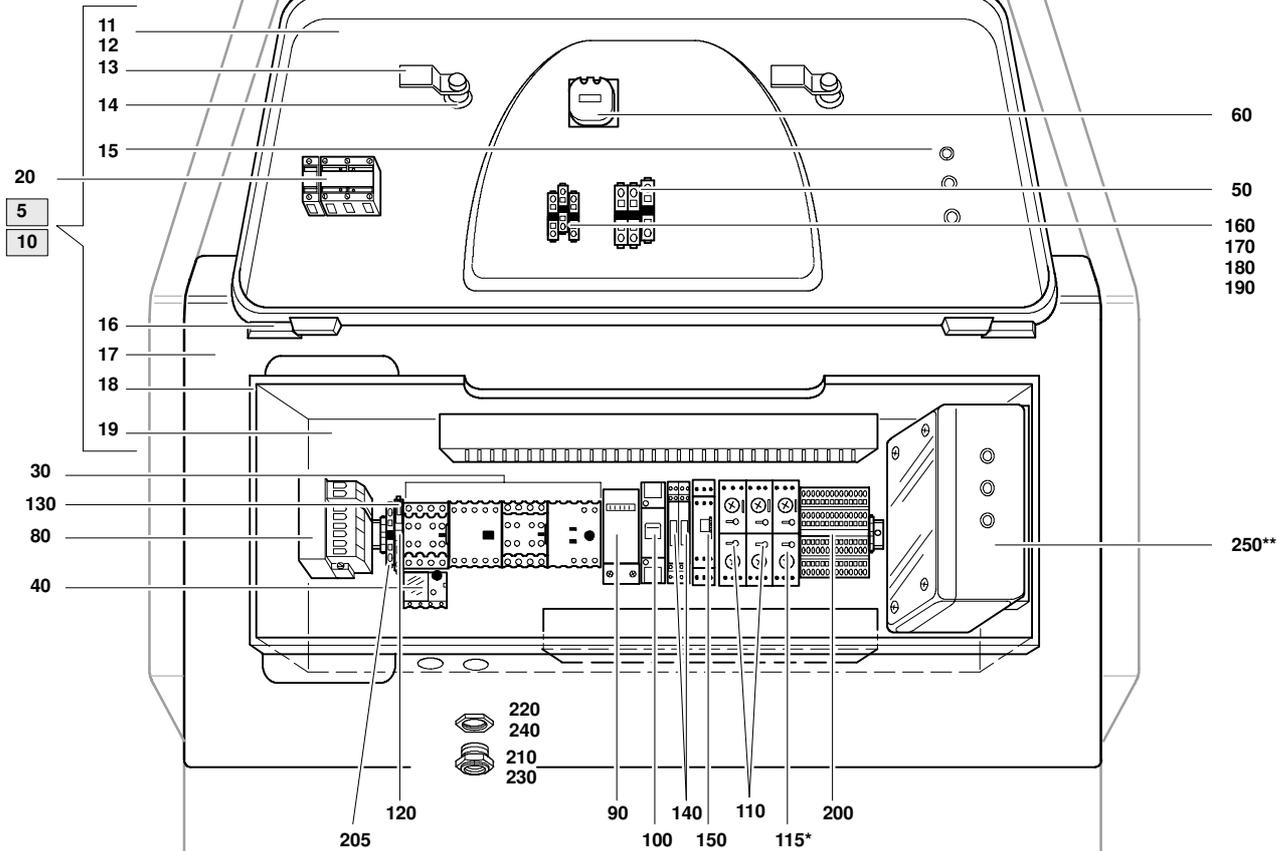

Ersatzteilsätze
 Spare parts sets
 Kits de pièces dét.

Baugruppe 83015 Kompressorsteuerung 5,5 kW; 380 - 440 VAC, 4 kW; 220 VAC
Assembly 83015 Compressor control unit 5,5 kW; 380 - 440 VAC, 4 kW; 220 VAC
Assemblage 83015 Unité de commande 5,5 kW; 380 - 440 VAC, 4 kW; 220 VAC

G68.0- 1

Klasse/ Class/ Classe			Pos.	Bestell-Nr. Part No. No. de cde.	Anz. Qty. Qté.	Benennung	Designation	Dénomination
a	b	c						
			5	83551	1	Schaltkasten kpl.	electric box assy	boîtier électrique cpl.
			10	83551-S01	1	Schaltkasten ohne Securus kpl.	electric box without Securus assy	boîtier électrique sans Securus cpl.
			11	83625	1	Deckel	cover	couvercle
			12	83625-S01	1	Deckel, ohne Securus	cover, without Securus	couvercle, sans Securus
			13	N28394	2	Zunge	tongue	languette
			14	N18970	2	Vorreiber	lock	vérou
			15	N27791	3	Abdecklinse	lens	lentille
			16	N272795	2	Scharnier	hinge fitting	charnière
			17	82344	1	Gehäuse	housing	boîtier
			18	81817	1	Oberteil	cover plate	façade
			19	82344-06	1	Montageplatte	mounting plate	plaque de montage
			20	N28553	1	Hauptschalter	main switch	interrupteur principal
			30	N29321	1	Stern-dreieck-Kombination	star-delta device	ensemble étoile-triangle
			40	N28689	1	Überlastrelais	overload relay	relais de surcharge
			50	N26308	1	Taster	switch	interrupteur
			60	N23853	1	Betriebsstundenzähler	hour meter	compteur d'heures
			80	N27708	1	Steuertransformator	control transformer	transformateur
			90	N19096	1	Summierzähler	cycle counter	compteur/totalisateur
			100	N16206	1	Installationsschalter	installation switch	interrupteur d'installation
			110	N26809	2	Taktgeber	timer	minuterie
			115*	N26809	1	Taktgeber	timer	minuterie
			120	N27877	6	Sicherungsautomat	safety automatic	disjoncteur
			130	N27878	1	Sicherungsklemme	safety terminal	support disjoncteur
			140	N22441	2	Schnittstellenrelais	intersection relay	relais d'interface
			150	N26439	1	Zeitrelais, Öl Druck	time relay, oil pressure	relais, pression d'huile
			160	N26313	1	LED-Element	LED element	LED
			170	N26310	1	Befestigungsflansch	mounting bracket	bride de fixation
			180	N26443	1	Meldeleuchte, o. Linse	warning light, without lens	lampe, sans lentille
			190	N26852	1	Linse, Ölsymbol	lens, oil symbol	lentille, symbole manque d'huile

*

Nur Anlagen mit Zwischenfilter nach 1.Stufe

Only groups with filter after 1st stage

Seuls groupes avec filtre après le 1er étage

G68.0-3

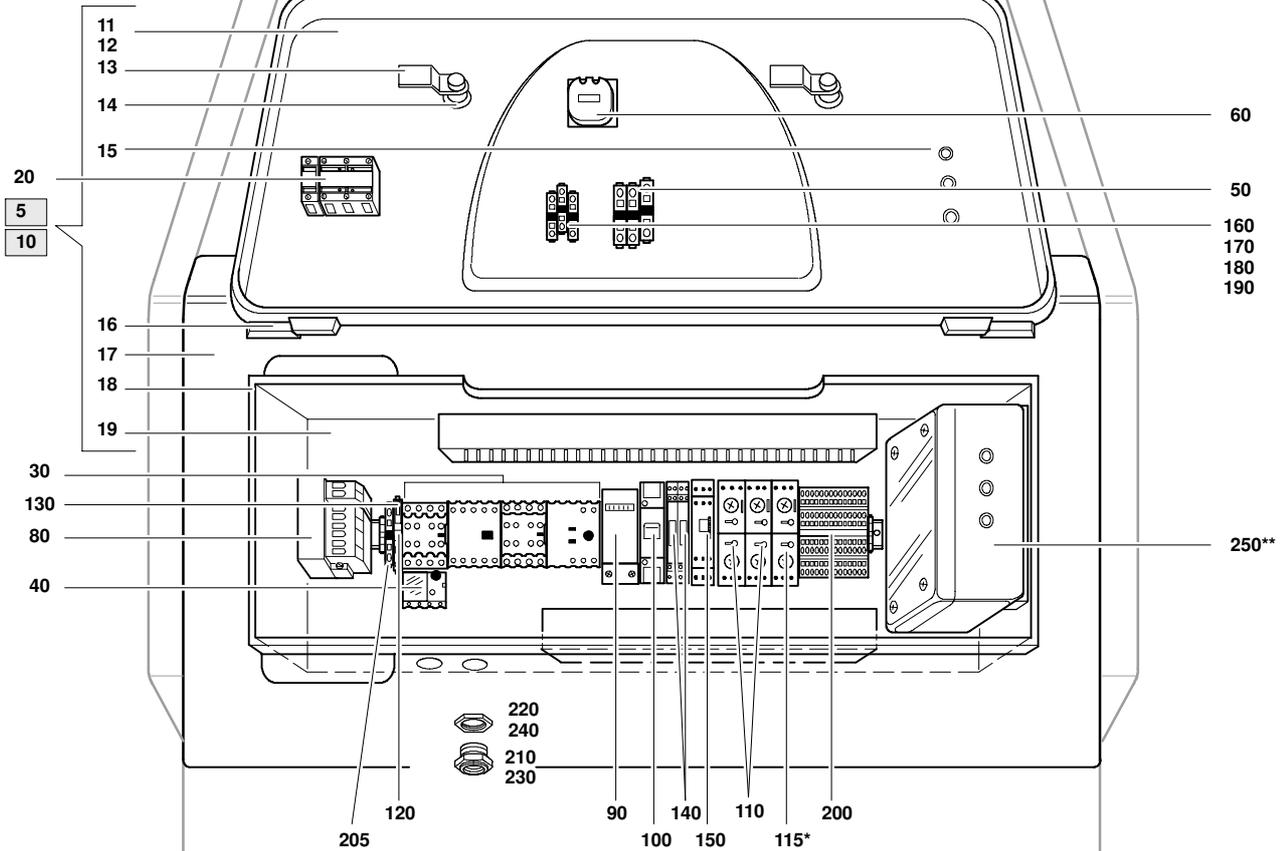

Ersatzteilsätze
Spare parts sets
Kits de pièces dét.

Baugruppe 83015 Kompressorsteuerung 5,5 kW; 380 - 440 VAC, 4 kW; 220 VAC
 Assembly 83015 Compressor control unit 5,5 kW; 380 - 440 VAC, 4 kW; 220 VAC
 Assemblage 83015 Unité de commande 5,5 kW; 380 - 440 VAC, 4 kW; 220 VAC

G68.0- 1

Klasse/ Class/ Classe			Pos.	Bestell-Nr. Part No. No. de cde.	Anz. Qty. Qté.	Benennung	Designation	Dénomination
a	b	c						
			200	N25767	11	Doppelklemme	double clamp	borne double
			205	N27020	3	Doppelklemme	double clamp	borne double
			210	N26722	1	Kabelverschraubung, M25	cable coupling, M25	raccord, M25
			220	N25560	1	Gegenmutter, M25	counternut, M25	contre-écrou, M25
			230	N26721	3	Kabelverschraubung, M20	cable coupling, M20	raccord, M20
			240	N25559	3	Gegenmutter, M20	counternut, M20	contre-écrou, M20
			250**	83638	1	Securus-Meldegerät kpl.	Securus alarm assy	alarme Securus cpl.

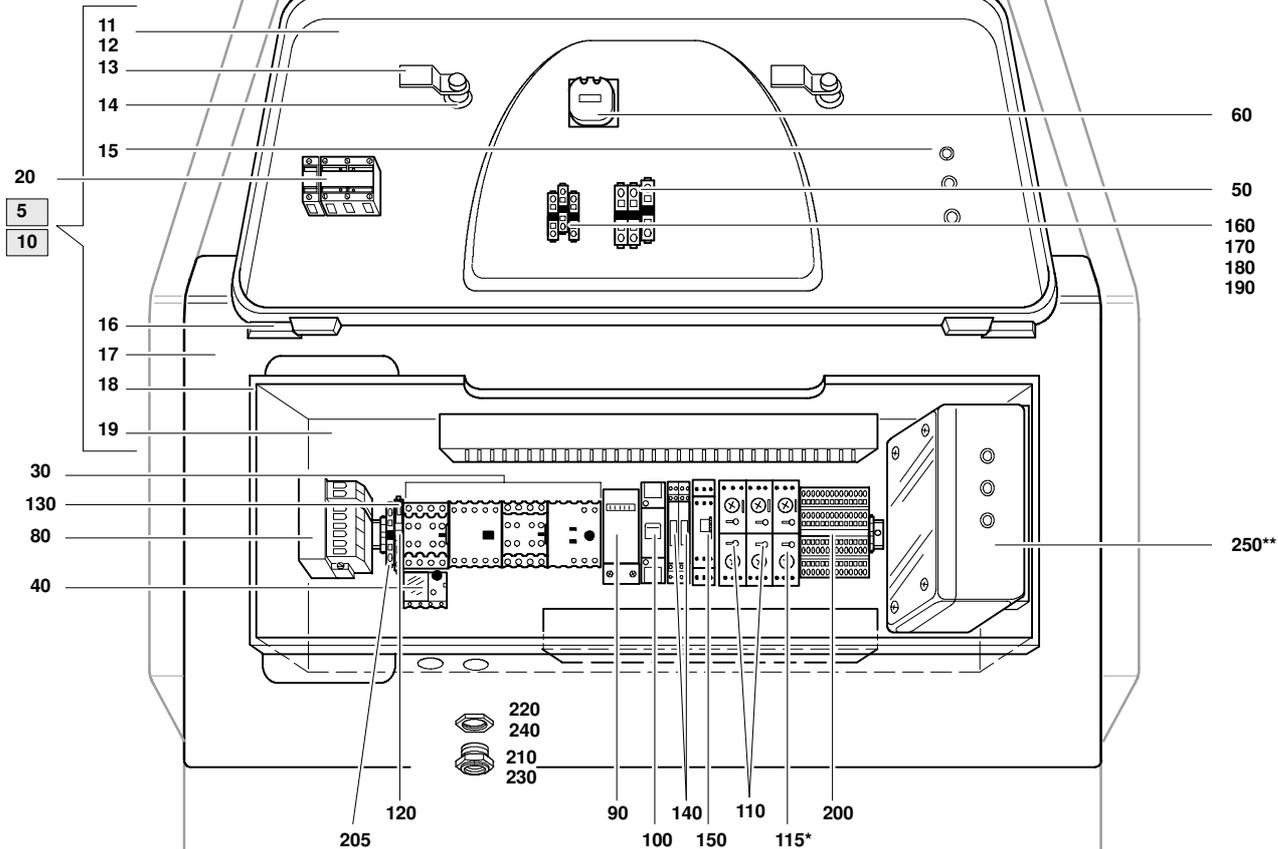

Ersatzteilsätze
 Spare parts sets
 Kits de pièces dét.

Baugruppe 84201 Kompressorsteuerung 4 kW; 380 - 440 VAC
Assembly 84201 Compressor control unit 4 kW; 380 - 440 VAC
Assemblage 84201 Unité de commande 4 kW; 380 - 440 VAC

G68.0- 2

Klasse/ Class/ Classe			Pos.	Bestell-Nr. Part No. No. de cde.	Anz. Qty. Qté.	Benennung	Designation	Dénomination
a	b	c						
			5	83551	1	Schaltkasten kpl.	electric box assy	boîtier électrique cpl.
			10	83551-S01	1	Schaltkasten ohne Securus kpl.	electric box without Securus assy	boîtier électrique sans Securus cpl.
			11	83625	1	Deckel	cover	couvercle
			12	83625-S01	1	Deckel, ohne Securus	cover, without Securus	couvercle, sans Securus
			13	N28394	2	Zunge	tongue	languette
			14	N18970	2	Vorreiber	lock	vérou
			15	N27791	3	Abdecklinse	lens	lentille
			16	N272795	2	Scharnier	hinge fitting	charnière
			17	82344	1	Gehäuse	housing	boîtier
			18	81817	1	Oberteil	cover plate	façade
			19	82344-06	1	Montageplatte	mounting plate	plaque de montage
			20	N28553	1	Hauptschalter	main switch	interrupteur principal
			30	N29321	1	Stern-dreieck-Kombination	star-delta device	ensemble étoile-triangle
			40	N29322	1	Überlastrelais	overload relay	relais de surcharge
			50	N26308	1	Taster	switch	interrupteur
			60	N23853	1	Betriebsstundenzähler	hour meter	compteur d'heures
			80	N27708	1	Steuertransformator	control transformer	transformateur
			90	N19096	1	Summierzähler	cycle counter	compteur/totalisateur
			100	N16206	1	Installationsschalter	installation switch	interrupteur d'installation
			110	N26809	2	Taktgeber	timer	minuterie
			115*	N26809	1	Taktgeber	timer	minuterie
			120	N27877	7	Sicherungsautomat	safety automatic	disjoncteur
			130	N27878	1	Sicherungsklemme	safety terminal	support disjoncteur
			140	N22441	2	Schnittstellenrelais	intersection relay	relais d'interface
			150	N26439	1	Zeitrelais, Öl Druck	time relay, oil pressure	relais, pression d'huile
			160	N26313	1	LED-Element	LED element	LED
			170	N26310	1	Befestigungsflansch	mounting bracket	bride de fixation
			180	N26443	1	Meldeleuchte, o. Linse	warning light, without lens	lampe, sans lentille
			190	N26852	1	Linse, Ölsymbol	lens, oil symbol	lentille, symbole manque d'huile

*

Nur Anlagen mit Zwischenfilter nach 1.Stufe

Only groups with filter after 1st stage

Seuls groupes avec filtre après le 1er étage
 G68.0-5

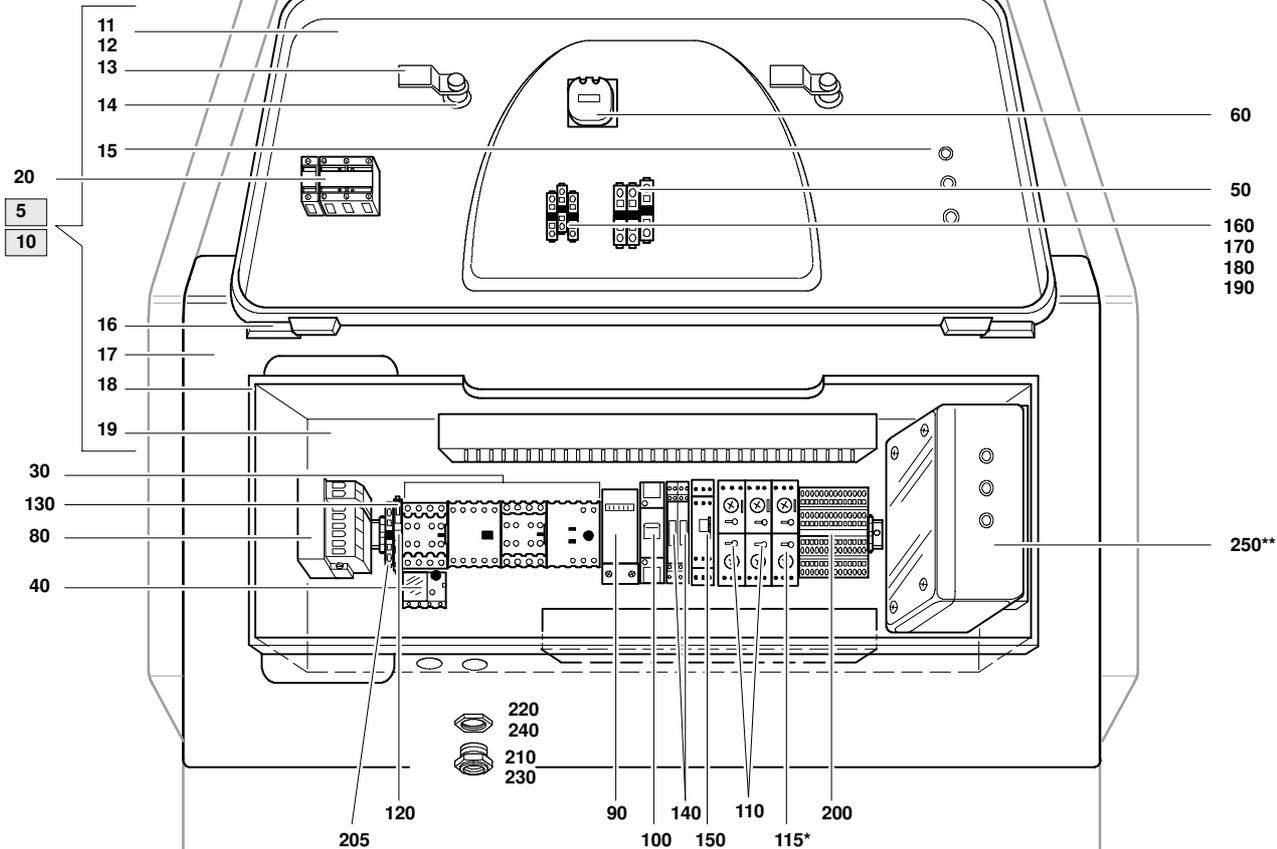

Ersatzteilsätze
Spare parts sets
Kits de pièces dét.

Baugruppe 84201 Kompressorsteuerung 4 kW; 380 - 440 VAC
 Assembly 84201 Compressor control unit 4 kW; 380 - 440 VAC
 Assemblage 84201 Unité de commande 4 kW; 380 - 440 VAC

G68.0- 2

Klasse/ Class/ Classe			Pos.	Bestell-Nr. Part No. No. de cde.	Anz. Qty. Qté.	Benennung	Designation	Dénomination
a	b	c						
			200	N25767	11	Doppelklemme	double clamp	borne double
			205	N27020	3	Doppelklemme	double clamp	borne double
			210	N26722	1	Kabelverschraubung, M25	cable coupling, M25	raccord, M25
			220	N25560	1	Gegenmutter, M25	counternut, M25	contre-écrou, M25
			230	N26721	3	Kabelverschraubung, M20	cable coupling, M20	raccord, M20
			240	N25559	3	Gegenmutter, M20	counternut, M20	contre-écrou, M20
			250**	83638	1	Securus-Meldegerät kpl.	Securus alarm assy	alarme Securus cpl.

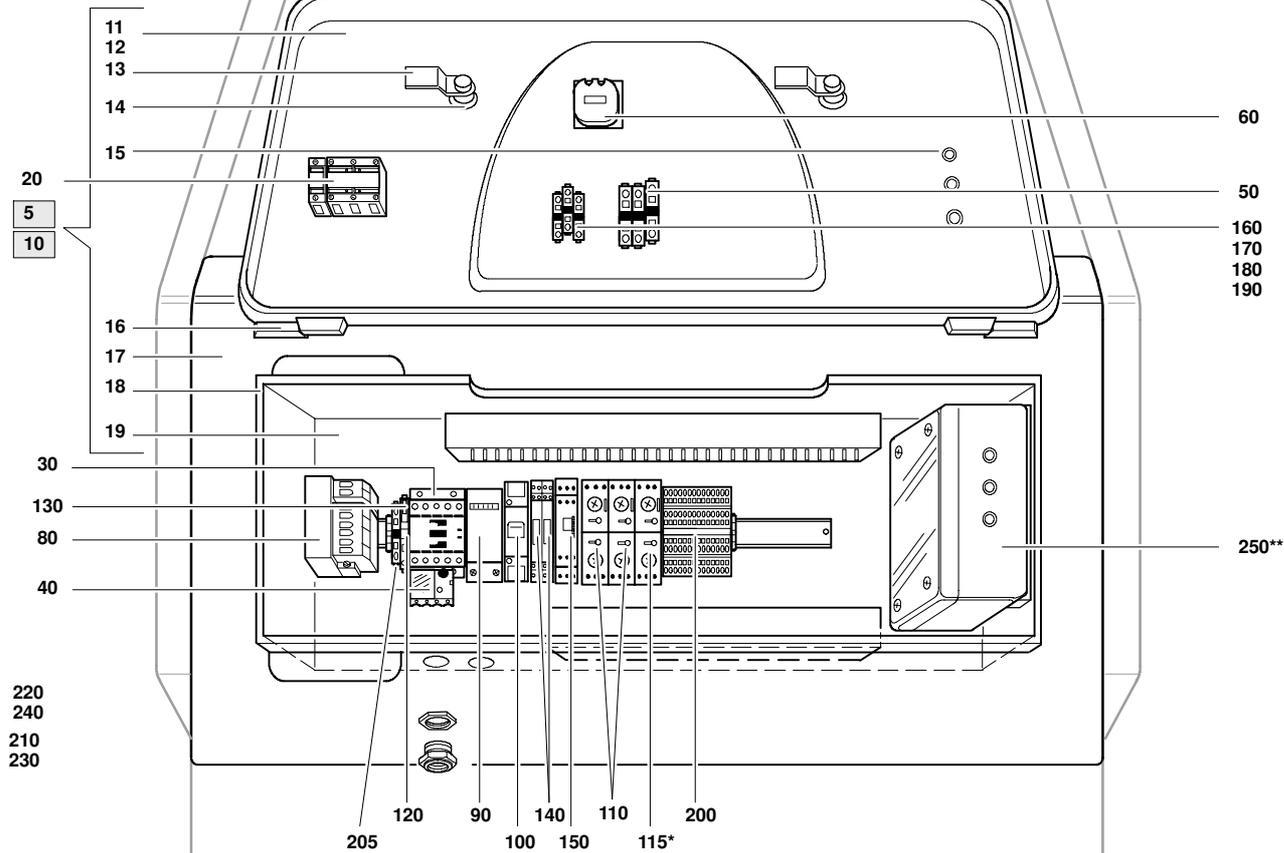

Ersatzteilsätze
 Spare parts sets
 Kits de pièces dét.

Baugruppe 84200 Kompressorsteuerung 3 kW; 380 - 440 VAC
 Assembly 84200 Compressor control unit 3 kW; 380 - 440 VAC
 Assemblage 84200 Unité de commande 3 kW; 380 - 440 VAC

G68.0- 3

Klasse/ Class/ Classe			Pos.	Bestell-Nr. Part No. No. de cde.	Anz. Qty. Qté.	Benennung	Designation	Dénomination
a	b	c						
			5	83551	1	Schaltkasten kpl.	electric box assy	boîtier électrique cpl.
			10	83551-S01	1	Schaltkasten ohne Securus kpl.	electric box without Securus assy	boîtier électrique sans Securus cpl.
			11	83625	1	Deckel	cover	couvercle
			12	83625-S01	1	Deckel, ohne Securus	cover, without Securus	couvercle, sans Securus
			13	N28394	2	Zunge	tongue	languette
			14	N18970	2	Vorreiber	lock	vérou
			15	N27791	3	Abdecklinse	lens	lentille
			16	N272795	2	Scharnier	hinge fitting	charnière
			17	82344	1	Gehäuse	housing	boîtier
			18	81817	1	Oberteil	cover plate	façade
			19	82344-06	1	Montageplatte	mounting plate	plaque de montage
			20	N28553	1	Hauptschalter	main switch	interrupteur principal
			30	N29323	1	Motorschütz	motor relay	contacteur-disjoncteur du moteur
			40	N29322	1	Überlastrelais	overload relay	relais de surcharge
			50	N26308	1	Taster	switch	interrupteur
			60	N23853	1	Betriebsstundenzähler	hour meter	compteur d'heures
			80	N27708	1	Steuertransformator	control transformer	transformateur
			90	N19096	1	Summierzähler	cycle counter	compteur/totalisateur
			100	N16206	1	Installationsschalter	installation switch	interrupteur d'installation
			110	N26809	2	Taktgeber	timer	minuterie
			115*	N26809	1	Taktgeber	timer	minuterie
			120	N27877	8	Sicherungsautomat	safety automatic	disjoncteur
			130	N27878	1	Sicherungsklemme	safety terminal	support disjoncteur
			140	N22441	2	Schnittstellenrelais	intersection relay	relais d'interface
			150	N26439	1	Zeitrelais, Öl Druck	time relay, oil pressure	relais, pression d'huile
			160	N26313	1	LED-Element	LED element	LED
			170	N26310	1	Befestigungsflansch	mounting bracket	bride de fixation
			180	N26443	1	Meldeleuchte, o. Linse	warning light, without lens	lampe, sans lentille
			190	N26852	1	Linse, Ölsymbol	lens, oil symbol	lentille, symbole manque d'huile

*

Nur Anlagen mit Zwischenfilter nach 1.Stufe

Only groups with filter after 1st stage

Seuls groupes avec filtre après le 1er étage
 G68.0-7

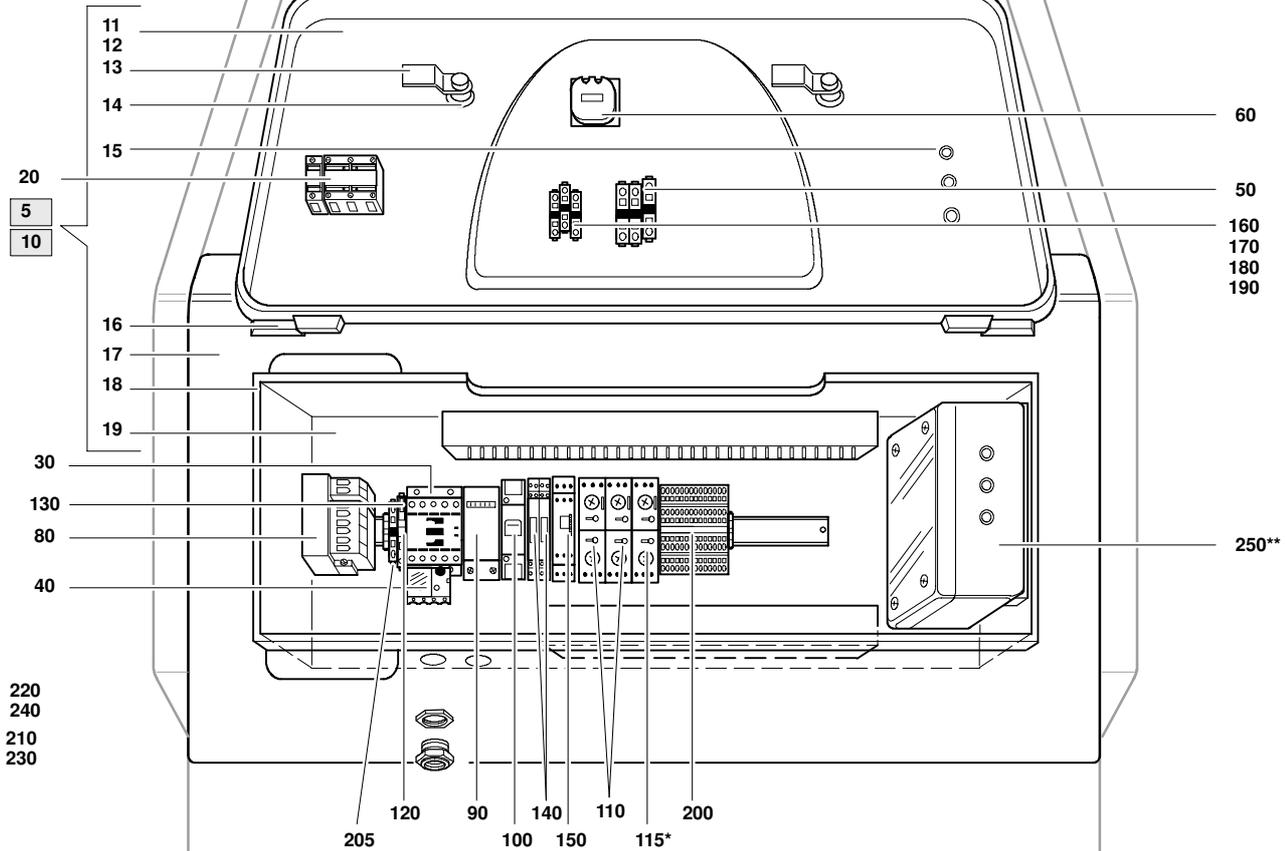

Ersatzteilsätze
Spare parts sets
Kits de pièces dét.

Baugruppe 84200 Kompressorsteuerung 3 kW; 380 - 440 VAC
 Assembly 84200 Compressor control unit 3 kW; 380 - 440 VAC
 Assemblage 84200 Unité de commande 3 kW; 380 - 440 VAC

G68.0- 3

Klasse/ Class/ Classe			Pos.	Bestell-Nr. Part No. No. de cde.	Anz. Qty. Qté.	Benennung	Designation	Dénomination
a	b	c						
			200	N25767	11	Doppelklemme	double clamp	borne double
			205	N27020	3	Doppelklemme	double clamp	borne double
			210	N26722	1	Kabelverschraubung, M25	cable coupling, M25	raccord, M25
			220	N25560	1	Gegenmutter, M25	counternut, M25	contre-écrou, M25
			230	N26721	3	Kabelverschraubung, M20	cable coupling, M20	raccord, M20
			240	N25559	3	Gegenmutter, M20	counternut, M20	contre-écrou, M20
			250**	83638	1	Securus-Meldegerät kpl.	Securus alarm assy	alarme Securus cpl.

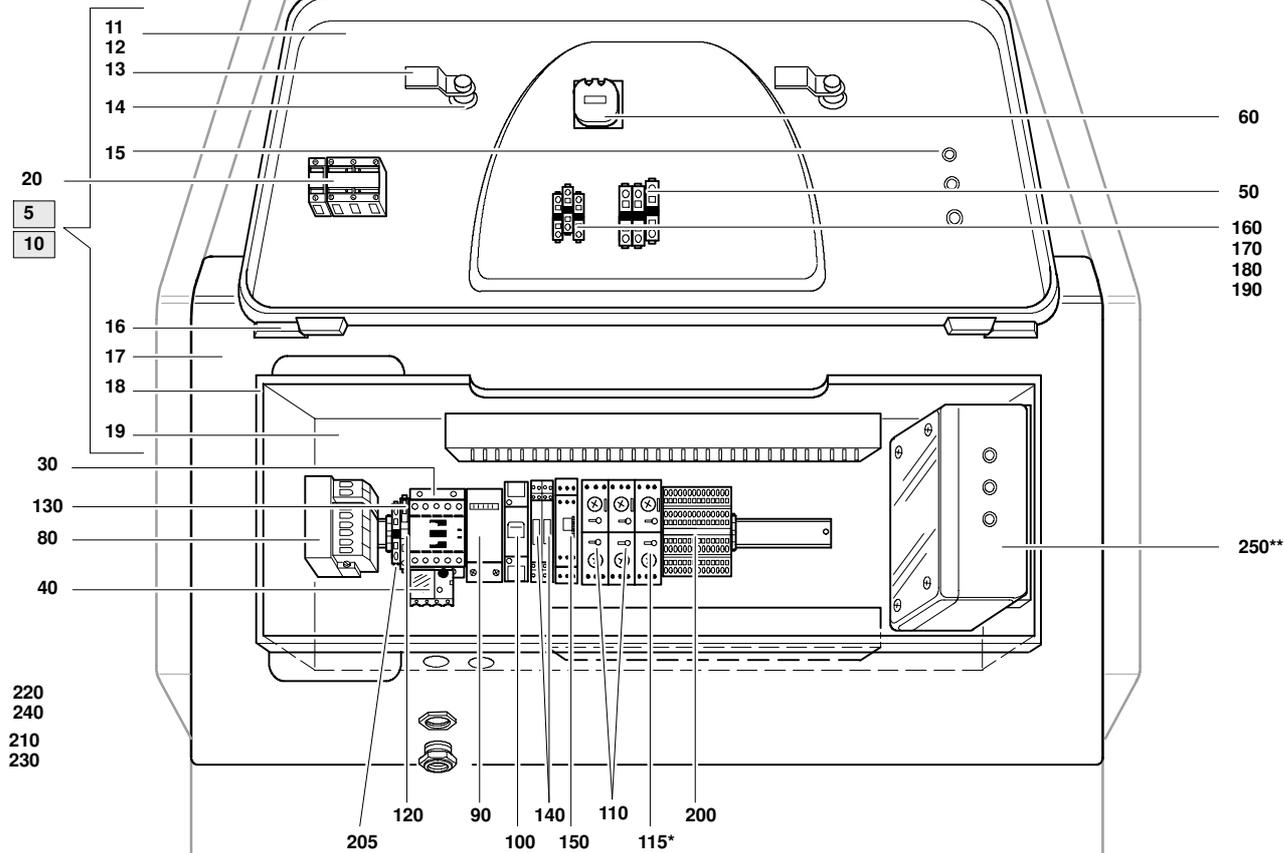

Ersatzteilsätze
 Spare parts sets
 Kits de pièces dét.

Baugruppe 84202 Kompressorsteuerung 3 kW; 220 VAC
 Assembly 84202 Compressor control unit 3 kW; 220 VAC
 Assemblage 84202 Unité de commande 3 kW; 220 VAC

G68.0- 4

Klasse/ Class/ Classe			Pos.	Bestell-Nr. Part No. No. de cde.	Anz. Qty. Qté.	Benennung	Designation	Dénomination
a	b	c						
			5	83551	1	Schaltkasten kpl.	electric box assy	boîtier électrique cpl.
			10	83551-S01	1	Schaltkasten ohne Securus kpl.	electric box without Securus assy	boîtier électrique sans Securus cpl.
			11	83625	1	Deckel	cover	couvercle
			12	83625-S01	1	Deckel, ohne Securus	cover, without Securus	couvercle, sans Securus
			13	N28394	2	Zunge	tongue	languette
			14	N18970	2	Vorreiber	lock	vérou
			15	N27791	3	Abdecklinse	lens	lentille
			16	N272795	2	Scharnier	hinge fitting	charnière
			17	82344	1	Gehäuse	housing	boîtier
			18	81817	1	Oberteil	cover plate	façade
			19	82344-06	1	Montageplatte	mounting plate	plaque de montage
			20	N28553	1	Hauptschalter	main switch	interrupteur principal
			30	N29324	1	Motorschütz	motor relay	contacteur-disjoncteur du moteur
			40	N28694	1	Überlastrelais	overload relay	relais de surcharge
			50	N26308	1	Taster	switch	interrupteur
			60	N23853	1	Betriebsstundenzähler	hour meter	compteur d'heures
			80	N27708	1	Steuertransformator	control transformer	transformateur
			90	N19096	1	Summierzähler	cycle counter	compteur/totalisateur
			100	N16206	1	Installationsschalter	installation switch	interrupteur d'installation
			110	N26809	2	Taktgeber	timer	minuterie
			115*	N26809	1	Taktgeber	timer	minuterie
			120	N27877	9	Sicherungsautomat	safety automatic	disjoncteur
			130	N27878	1	Sicherungsklemme	safety terminal	support disjoncteur
			140	N22441	2	Schnittstellenrelais	intersection relay	relais d'interface
			150	N26439	1	Zeitrelais, Öl Druck	time relay, oil pressure	relais, pression d'huile
			160	N26313	1	LED-Element	LED element	LED
			170	N26310	1	Befestigungsflansch	mounting bracket	bride de fixation
			180	N26443	1	Meldeleuchte, o. Linse	warning light, without lens	lampe, sans lentille
			190	N26852	1	Linse, Ölsymbol	lens, oil symbol	lentille, symbole manque d'huile

*

Nur Anlagen mit Zwischenfilter nach 1.Stufe

Only groups with filter after 1st stage

Seuls groupes avec filtre après le 1er étage
 G68.0-9

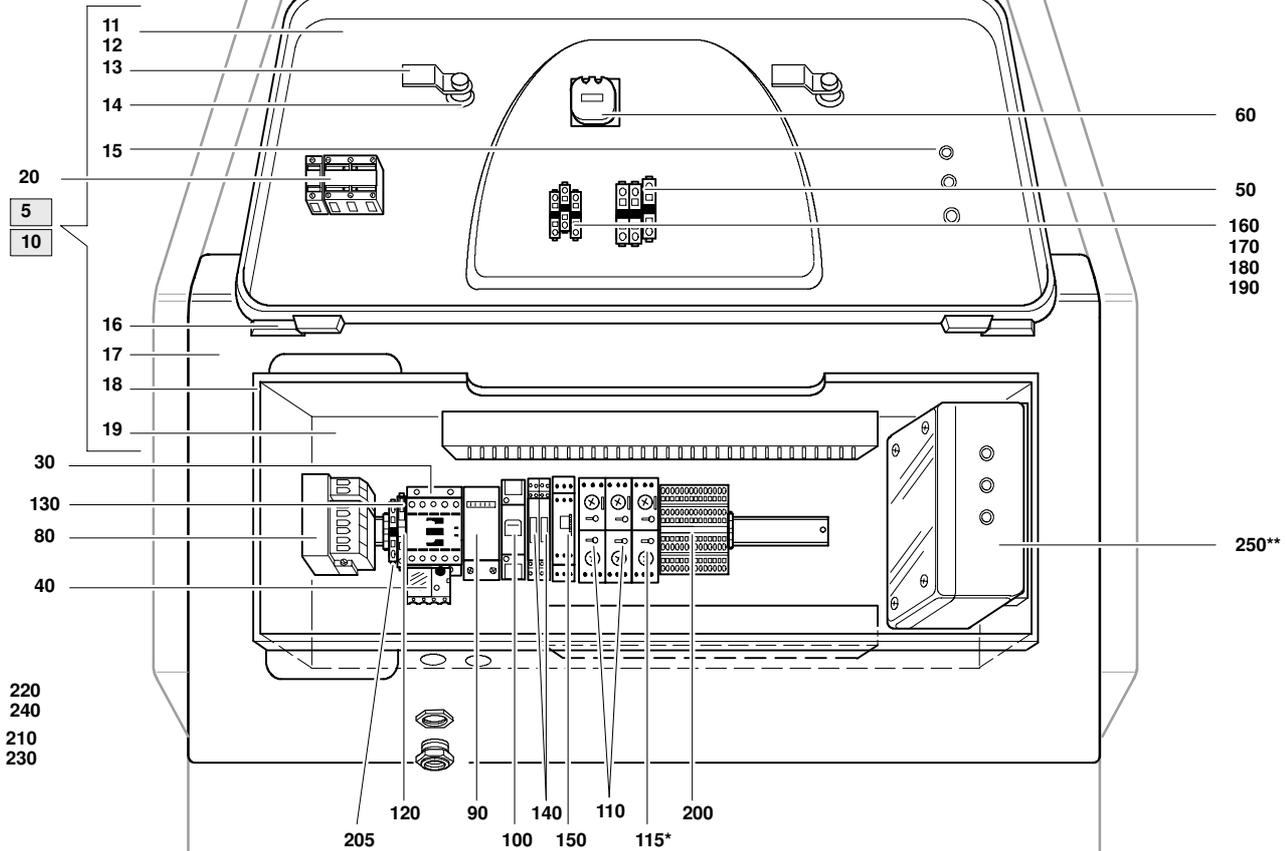

Ersatzteilsätze
Spare parts sets
Kits de pièces dét.

Baugruppe 84202 Kompressorsteuerung 3 kW; 220 VAC
 Assembly 84202 Compressor control unit 3 kW; 220 VAC
 Assemblage 84202 Unité de commande 3 kW; 220 VAC

G68.0- 4

Klasse/ Class/ Classe			Pos.	Bestell-Nr. Part No. No. de cde.	Anz. Qty. Qté.	Benennung	Designation	Dénomination
a	b	c						
			200	N25767	11	Doppelklemme	double clamp	borne double
			205	N27020	3	Doppelklemme	double clamp	borne double
			210	N26722	1	Kabelverschraubung, M25	cable coupling, M25	raccord, M25
			220	N25560	1	Gegenmutter, M25	counternut, M25	contre-écrou, M25
			230	N26721	3	Kabelverschraubung, M20	cable coupling, M20	raccord, M20
			240	N25559	3	Gegenmutter, M20	counternut, M20	contre-écrou, M20
			250**	83638	1	Securus-Meldegerät kpl.	Securus alarm assy	alarme Securus cpl.

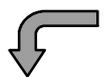
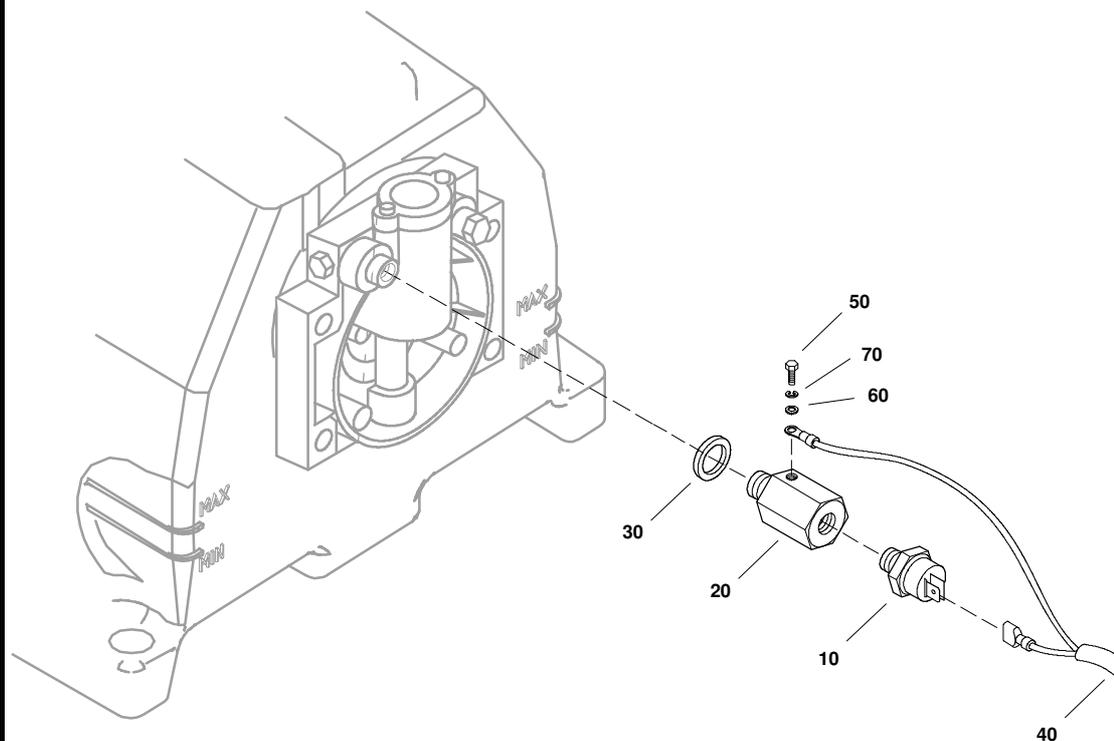

Wartungssätze
 Maintenance sets
 Kits d'entretien

Baugruppe 80500 Öldrucküberwachung
 Assembly 80500 Oil pressure monitoring
 Assemblage 80500 Surveillance de la pression d'huile

G68.0- 5

Klasse/ Class/ Classe			Pos.	Bestell-Nr. Part No. No. de cde.	Benennung	Designation	Dénomination
a	b	c					
			10	N26437	Druckschalter	pressure switch	pressostat
			20	80497	Adapter	adaptor	adaptateur
			30	N4602	USIT-Ring	USIT ring	joint USIT
			40	N21659	Steuerleitung	connecting cable	câble de connexion
			50	N26453	Sechskantschraube	hex. screw	boulon
			60	N2949	Scheibe	washer	rondelle
			70	N635	Federring	spring washer	rondelle fendue

