

Ersatzteilliste
Spare parts catalogue
Catalogue des pièces

TUCM2-4/0

Atemluft-Kompressoranlagen
Breathing air compressor units
Groupes compresseurs à air respirable

Utilus II
Capitano II
Mariner II



Auflage Juni 2004 / Edition June 2004 / Edition Juin 2004

TEILELISTE
TUCM-4/0

 ist gültig ab **Juni 2004**
 für Kompressor typ

Utilus
CAPITANO
MARINER
PARTS LIST
TUCM-4/0

 is valid as of **June 2004**
 for compressor model

Utilus
CAPITANO
MARINER
CATALOGUE DES PIECES
TUCM-4/0

 est valable à partir de **Juin 2004**
 pour les compresseurs de type

Utilus
CAPITANO
MARINER

Baugruppe	Assembly	Assemblage	Abb./fig.
Kurbelgehäuse mit Zubehör	Crankcase with accessories	Carter avec accessoires	TUCM-1
Triebwerk	driving gear	embellage	
Kolben, Zylinder 1. Stufe, IK100 II	Piston, cylinder 1st st., IK100 II	Piston, cylindre 1e étage, IK100 II	TUCM-2
Kolben, Zylinder 1. Stufe, IK120 II	Piston, cylinder 1st st., IK120 II	Piston, cylindre 1e étage, IK120 II	TUCM-3
Kolben, Zylinder 2. Stufe	Piston, cylinder 2nd stage	Piston, cylindre 2e étage	TUCM-4
Kolben, Zylinder 3. Stufe	Piston, cylinder 3rd stage	Piston, cylindre 3e étage	TUCM-5
Ventilkopf, 1. Stufe, IK100 II	Valve head, 1st stage, IK100 II	Culasse de 1er étage, IK100 II	TUCM-6
Ventilkopf, 1. Stufe, IK120 II	Valve head, 1st stage, IK120 II	Culasse de 1er étage, IK120 II	TUCM-7
Ventilkopf, 2. Stufe	Valve head, 2nd stage	Culasse de 2e étage	TUCM-8
Ventilkopf, 3. Stufe	Valve head, 3rd stage	Culasse de 3e étage	TUCM-9
Schwungrad	Flywheel	Volant	TUCM-10
Zwischenfilter	Intermediate separator	Séparateur intermédiaire	TUCM-11
Kühlung, IK100 II	Cooling system, K100 II	Refroidissement, IK100 II	TUCM-12
Kühlung, IK120 II	Cooling system, K120 II	Refroidissement, IK120 II	TUCM-13
Druckölschmierung	Lubrication system	Lubrification	TUCM-14
Ansaugfilter	Intake filter	Filtre d'aspiration	TUCM-15
Kondensatablaßbahn	Condensate drain tap	Robinet de purge des condensats	TUCM-16
Zubehör	Accessories	Accessoires	TUCM-17
Zubehör, IK120 II	Accessories, K120 II	Accessoires, IK120 II	TUCM-18
Filtersystem P21	Filter system P21	Système de filtration P21	TUCM-19
Druckhalteventil, Fülleinrichtung	Pressure maintaining valve, filling device	Soupape de maintien de pression, dispositif de remplissage	TUCM-20
Umschalteinrichtung PN 200/PN 300*	Change over device PN200/PN300*	Dispositif sélecteur PN 200/PN 300*	TUCM-21
Filtersystem P41	Filter system P41	Système de filtration P41	TUCM-22
Tragrahmen, Utilus II, Capitano II	Portable frame, Utilus II, Capitano II	Cadre portable, Utilus II, Capitano II	TUCM-23
Sturzrahmen, Utilus II	Protection frame, Utilus II	Cadre de protection, Utilus II	TUCM-24
Sturzrahmen, Capitano II	Protection frame, Capitano II	Cadre de protection, Capitano II	TUCM-25
Sturzrahmen, Mariner II	Protection frame, Mariner II	Cadre de protection, Mariner II	TUCM-26
Sturzrahmen, Dieselanlagen	Protection frame, Diesel units	Cadre de protection, groupes Diesel	TUCM-27
Griff kpl.	Handle assy.	Poignées cpl.	TUCM-28
Antriebsmotoren, Utilus II	Driving motors, Utilus II	Moteurs d'entraînement, Utilus II	TUCM-29
Antriebsmotoren, Capitano II	Driving motors, Capitano II	Moteurs d'entraînement, Capitano II	TUCM-30
Antriebsmotoren, Mariner II	Driving motors, Mariner II	Moteurs d'entraînement, Mariner II	TUCM-31
Kondensatablaßautomatik*	Automatic condensate drain*	Purge automatique des condensats*	TUCM-32
Kondensatablaßventil 063760 kpl.*	Condensate drain valve 063760 assy.*	Soupape de purge des condensats 063760 cpl.*	TUCM-33
Kondensatablaßventil 075169 kpl.*	Condensate drain valve 075169 assy.*	Soupape de purge des condensats 075169 cpl.*	TUCM-34
Ansaugteleskop mit Anschlußteilen*	Intake pipe with connecting parts*	Conduite d'aspiration et raccords*	TUCM-35
Fahrsatz*	Undercarriage*	Chariot*	TUCM-36
Fahrsatz für Sturzrahmen*	Undercarriage for protection frame*	Chariot pour cadre de protection*	TUCM-37

*Zusatzausstattung *Optional extra *Option

Wichtige Hinweise für Teilebestellung:

Bestell-Nr., die mit der Ziffer 0 beginnen, bezeichnen Baugruppen, die komplett geliefert werden. Teile ohne Bestell-Nr. sind nur zur Information für die Montage aufgeführt. Sie sind nicht als Ersatzteil erhältlich. Bei Ersatzteilbestellungen erwarten Sie unsere richtige Lieferung; deshalb benötigen wir von Ihnen folgende Angaben (siehe unten gezeigtes Typenschild):

1. Modellbezeichnung, Fabrik-Nr. sowie Fertigungsstand von Anlage/Block
2. Stückzahlen
3. Benennung und Best.-Nr. des gewünschten Teils

Bestell-Beispiel:

Für Kompressoanlage ...
Fabrik-Nr. 524-0528/1/2 drei Dichtungen
8263-090

Important notes for spare parts orders:

Part nos. beginning with digit 0 indicate parts available as complete assemblies. Parts without part no. are indicated for assembly reference, only. These parts are not available as single parts. When placing an order for spare parts, please give the following items so as to ensure our correct delivery (see identification plate shown below):

1. Model, serial no. as well as design standard of unit/block
2. Quantity required
3. Name and part no.

Example for order:

For compressor unit ...
serial no. 524-0528/1/2, three gaskets
8263-090

Avis important pour la commande de pièces:

Les nos. de commande commençant par le chiffre 0 indiquent les pièces livrées au complet. Les pièces sans no. de commande sont indiquées uniquement pour information de montage. Elles ne sont pas livrées individuellement. Pour que la livraison de pièces de rechange corresponde à la commande, veuillez bien nous fournir les données suivantes (voir plaque d'identité ci-dessous):

1. Modèle, no. de série et standard de construction de bloc compresseur/groupe
2. Quantité désirée
3. Dénomination et no. de commande de la pièce désirée

Exemple de commande:

Pour groupe compresseur ...
no. de série 524-0528/1/2, trois joints no. cde. 8263-090



Wartungssätze

- a = Wartungssatz 500 h bzw. bei Bedarf
- b = Wartungssatz 1000 h, mind. jährlich
- c = Wartungssatz 2000 h, mind. alle 2 Jahre



Maintenance kits:

- a = Maintenance kit 500 h or as required
- b = Maintenance kit 1000 h, at least annually
- c = Maintenance kit 2000 h, at least biennially



Kits de maintenance :

- a = Kit d'entretien 500 h ou au besoin
- b = Kit d'entretien 1000 h, au moins un fois par an
- c = Kit d'entretien 2000 h, au moins tous les 2 ans

In den Spalten sind die im entsprechenden Satz enthaltenen Teile angekreuzt. Bitte beachten, daß die höheren Sätze die untergeordneten nicht beinhalten, d.h. für eine 2000-Stunden-Wartung wird 1x Satz a, 1x Satz b und 1x Satz c benötigt.

The columns contain the parts that are included in the respective parts set. Please note that the higher graded kits do not include the lower ones, i.e. for a 2000 hours maintenance, one kit a, one kit b plus one kit c are required.

Les pièces contenues dans les kits correspondants sont marquées d'une croix dans les colonnes. Veuillez observer que les kits supérieurs ne contiennent pas les kits subordonnés, c'est-à-dire pour un entretien de 2000 heures il faut avoir 1x kit a, 1x kit b et 1x kit c.

Anmerkungen zur Identifikation:
Remarks for identification:
Remarques pour l'identification:

Modell/Model/Modèle		Fabrik-Nr./Serial no./Numéro de série	
<input type="checkbox"/>		<input type="checkbox"/>	
Volumenstrom m ³ /min	<input type="checkbox"/>	Jahr / Year	<input type="checkbox"/>
Free air delivery Scfm	<input type="checkbox"/>	n/min. / r.p.m.	<input type="checkbox"/>
Betriebsüberdruck bar	<input type="checkbox"/>	kW	<input type="checkbox"/>
Max. working press. psig	<input type="checkbox"/>	KB 73708	
Fertigungsstand / Modification no. / No. de modification		Anlage/Unit/Groupe	
<input type="checkbox"/>		<input type="checkbox"/>	
Kompressorblock / Compressor block / Bloc compresseur		CE	
<input type="checkbox"/>		<input type="checkbox"/>	



ACHTUNG

Nur Schrauben und Stiftschrauben der Qualität 8.8 verwenden!



ATTENTION

Use only screws and studs in quality 8.8! This quality is equivalent to SAE J 429 d grade 5.



ATTENTION

N'utiliser que des vis et des goujons filetés de la qualité 8.8!

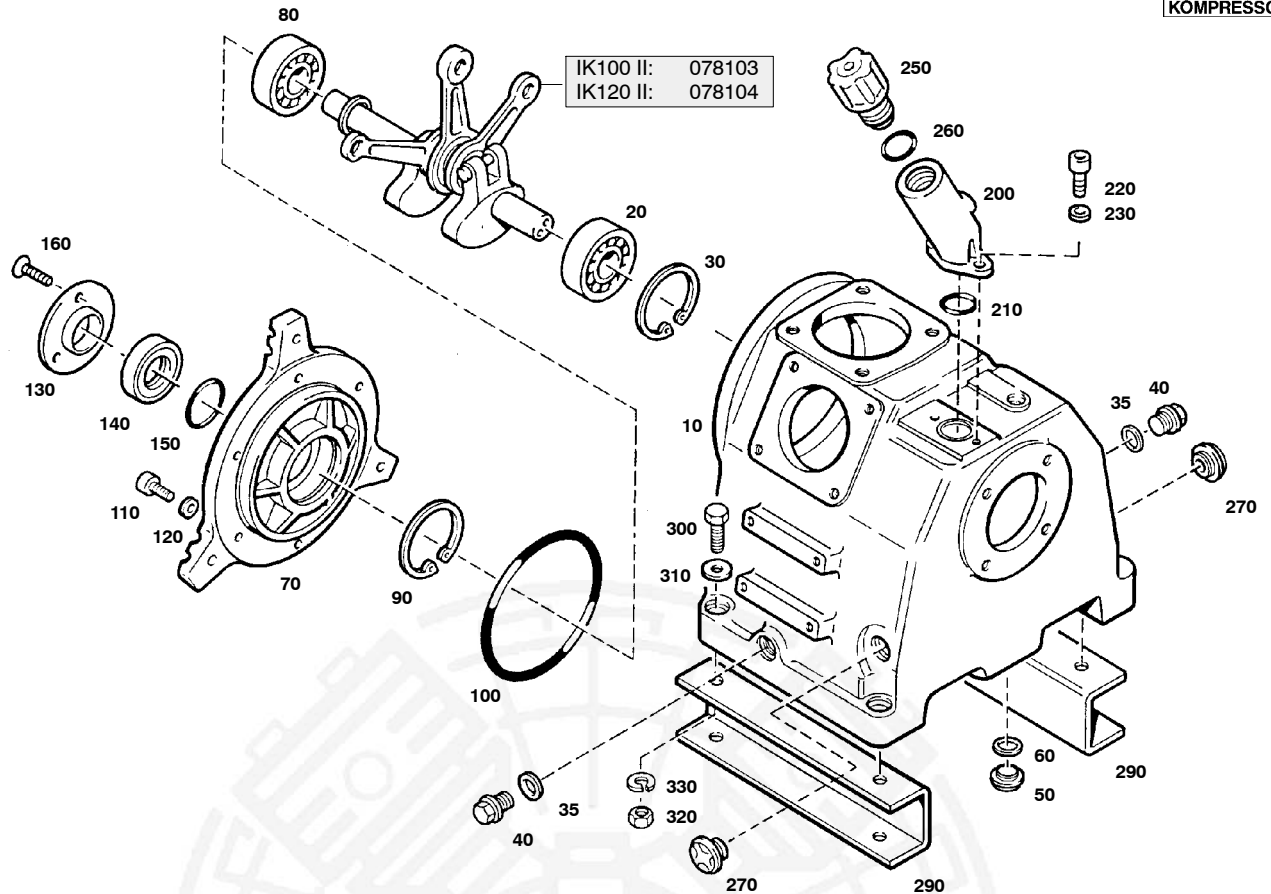
 Wartungssätze
 Maintenance sets
 Kits d'entretien

Baugruppe 076743
Assembly 076743
Assemblage 076743
Kurbelgehäuse, m. Zubehör, Triebwerk
Crankcase with accessories, driving gear
Carter avec accessoires, embiellage
TUCM-1

Klasse/ Class/ Classe			Pos.	Bestell-Nr. Part No. No. de cde.	Anz. Qty. Qté.	Benennung	Designation	Dénomination
a	b	c						
			10	76740	1	Kurbelgehäuse	crankcase	carter
			20	N2638	1	Zylinderrollenlager	cylindrical roller bearing	roulement à rouleaux
			30	N2635	1	Sicherungsring	circlip ring	circlip
X			35	N4163	2	Dichtring	gasket	joint
			40	N2796	2	Verschlußschraube	plug	bouchon fileté
			50	N4570	1	Verschlußschraube	plug	bouchon fileté
			60	N1316	1	Dichtring	gasket	joint
			70	66209	1	Lagerdeckel	bearing cap	chapeau de palier
			80	N15406	1	Zylinderrollenlager	cylindrical roller bearing	roulement à rouleaux
			90	N2635	1	Sicherungsring	circlip ring	circlip
			100	N15265	1	O-Ring	o-ring	joint torique
			110	N756	6	Sechskantschraube	hexagon screw	vis hexagonale
			120	N58	6	Scheibe	washer	rondelle
			130	66684	1	Deckel	cover	couvercle
			140	N170	1	Wellendichtring	shaft seal	bague d'étanchéité
			150	N3745	1	O-Ring	o-ring	joint torique
			160	N16128	3	Senkschraube	countersunk screw	vis noyée
			200	73830	1	Öleinfüllstutzen	oil filling pipe	tubulure de rempliss. d'huile
			210	N4776	1	O-Ring	o-ring	joint torique
			220	N88	2	Sechskantschraube	hexagon screw	vis hexagonale
			230	N58	2	Scheibe	washer	rondelle
			250	61054	1	Verschlußschraube	plug	bouchon fileté
			260	N15412	1	O-Ring	o-ring	joint torique
			270	N25475	2	Ölstandsauge	oil sight gauge	regard d'huile
			290	78038	2	Kompressorfuß	support	support

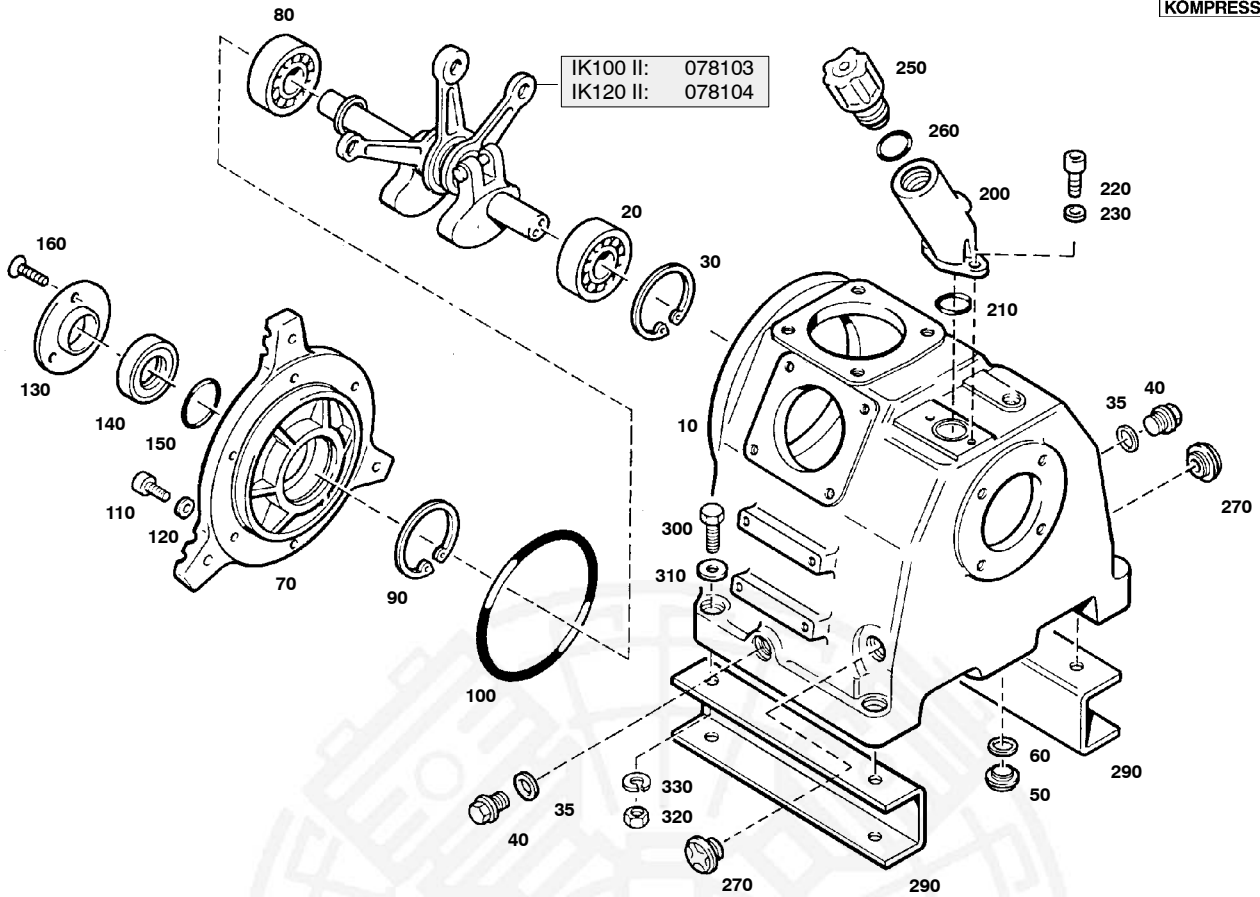

Wartungssätze
Maintenance sets
Kits d'entretien

Baugruppe 076743 Kurbelgehäuse, m. Zubehör, Triebwerk
Assembly 076743 Crankcase with accessories, driving gear
Assemblage 076743 Carter avec accessoires, embiellage

TUCM-1

Klasse/ Class/ Classe			Pos.	Bestell-Nr. Part No. No. de cde.	Anz. Qty. Qté.	Benennung	Designation	Dénomination
a	b	c						
			300	N350	4	Sechskantschraube	hexagon screw	vis hexagonale
			310	N16	4	Scheibe	washer	rondelle
			320	N176	4	Federring	spring washer	rondelle-ressort
			330	N177	4	Sechskantmutter	hexagon nut	écrou hexagonal

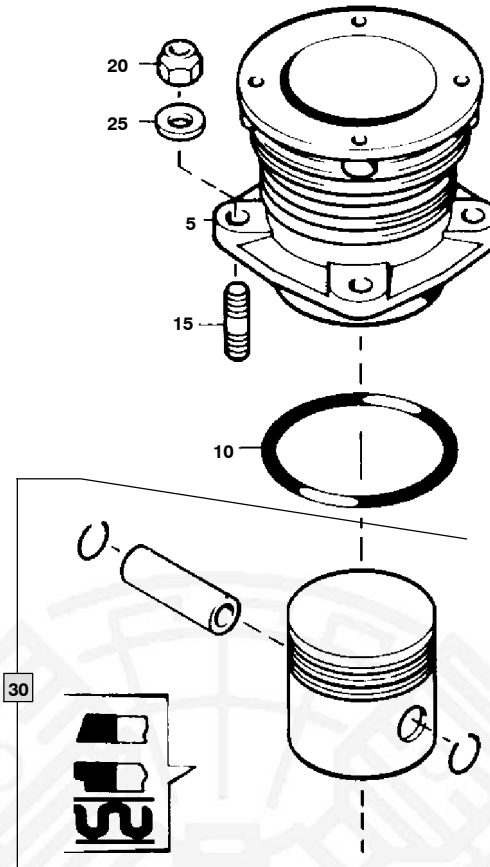

Wartungssätze
Maintenance sets
Kits d'entretien

Baugruppe 06665 Zylinder 1. Stufe IK100 II
Assembly 06665 Cylinder, 1st stage, IK100 II
Assemblage 06665 Cylindre, 1er étage IK100 II

TUCM-2

Klasse/ Class/ Classe			Pos.	Bestell-Nr. Part No. No. de cde.	Anz. Qty. Qté.	Benennung	Designation	Dénomination
a	b	c						
			5	66663	1	Zylinder	cylinder	cyindre
		X	10	N4654	1	O-Ring	o-ring	joint torique
			15	N215	4	Stiftschraube	stud	goujon fileté
		X	20	N370	4	Selbstsichernde Mutter	hexagon nut self-locking	écrou hexagonal auto-fr.
			25	N58	4	Scheibe	washer	rondelle
			30	069948	1	Kolben kpl.	piston cpl.	piston cpl.

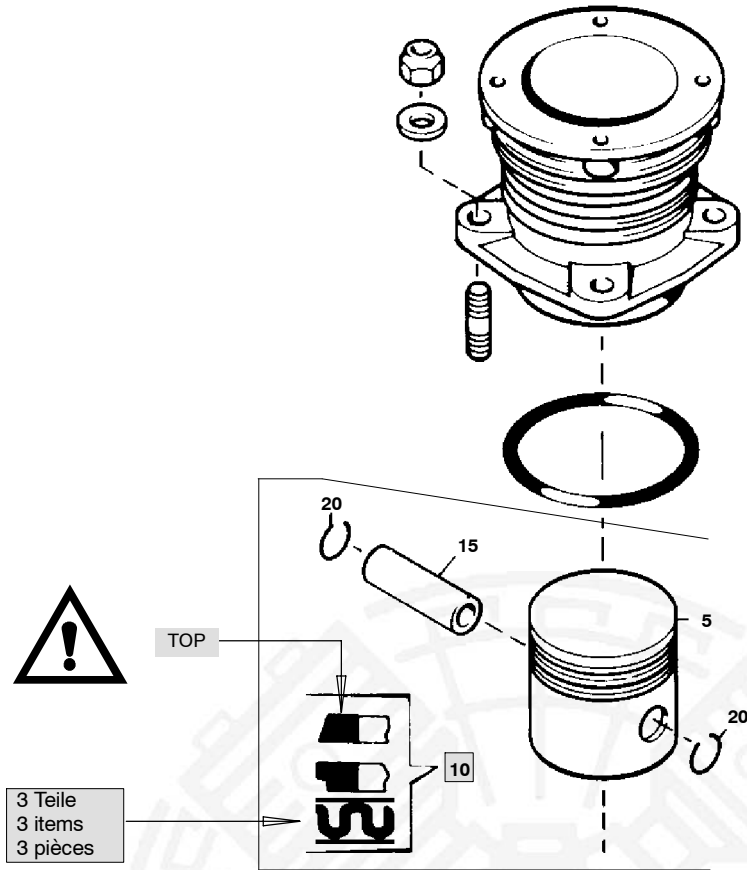

Wartungssätze
Maintenance sets
Kits d'entretien

Baugruppe 069948 Kolben kpl.
Assembly 069948 Piston cpl.
Assemblage 069948 Piston cpl.

TUCM-2a

Klasse/ Class/ Classe			Pos.	Bestell-Nr. Part No. No. de cde.	Anz. Qty. Qté.	Benennung	Designation	Dénomination
a	b	c						
			5	10704	1	Kolben	piston	piston
			10	N3856	1	Kolbenringsatz	piston ring set	jeu des segments
			15	N802	1	Kolbenbolzen	piston pin	axe de piston
			20	N484	2	Sicherungsring	circlip ring	rondelle de sûreté

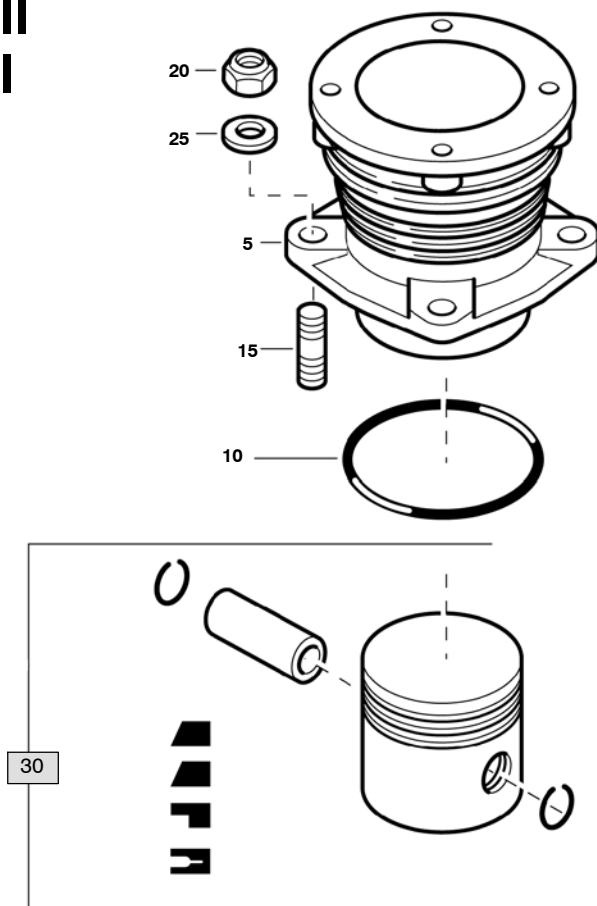
IK12.4 II
IK120 II

 Wartungssätze
 Maintenance sets
 Kits d'entretien

Baugruppe 80826
Assembly 80826
Assemblage 80826
Zylinder
Cylinder
Cylindre
TUCM-3

Klasse/ Class/ Classe			Pos.	Bestell-Nr. Part No. No. de cde.	Anz. Qty. Qté.	Benennung	Designation	Dénomination
a	b	c						
			5	80734	1	Zylinder	cylinder	cyindre
		X	10	N4654	1	O-Ring	o-ring	joint torique
			15	N215	4	Stiftschraube	stud	goujon fileté
			20	N58	4	Scheibe	washer	rondelle
		X	25	N370	4	Selbstsichernde Mutter	hexagon nut self-locking	écrou hexagonal auto-fr
			30	069975	1	Kolben kpl.	piston cpl.	piston cpl.

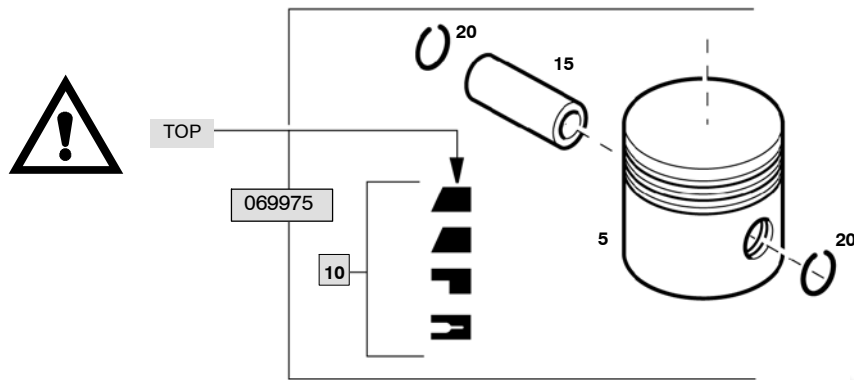
IK12.4 II IK120 II





 Wartungssätze
 Maintenance sets
 Kits d'entretien

Baugruppe 069975 Kolben kpl.
Assembly 069975 Piston cpl.
Assemblage 069975 Piston cpl.

TUCM-3a

Klasse/ Class/ Classe			Pos.	Bestell-Nr. Part No. No. de cde.	Anz. Qty. Qté.	Benennung	Designation	Dénomination
a	b	c						
			5		1	Kolben	piston	piston
			10	N1787	1	Kolbenringsatz	piston ring set	jeu des segments
			15		1	Kolbenbolzen	piston pin	axe de piston
			20	N484	2	Sicherungsring	circlip ring	rondelle de sûreté

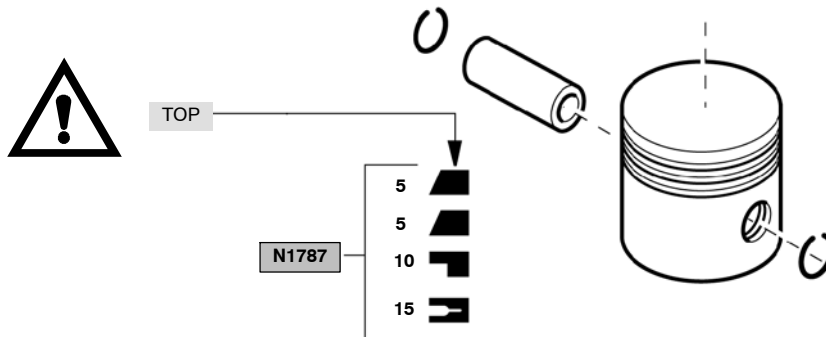
IK12.4 II IK120 II



 Wartungssätze Maintenance sets Kits d'entretien			Baugruppe N1787 Assembly N1787 Assemblage N1787		Kolbenringsatz kpl. Piston ring set cpl. Jeu des segments de piston cpl.		<h2>TUCM-3b</h2>	
Klasse/ Class/ Classe			Pos.	Bestell-Nr. Part No. No. de cde.	Anz. Qty. Qté.	Benennung	Designation	Dénomination
a	b	c						
			5	N110	2	Minutenring	taper faced ring	segment à faible conicité
			10	N122	1	Nasenring	stepped scraper ring	segment racleur
			15	N112	1	Ölschlitzring	grooved ring	segment à fente

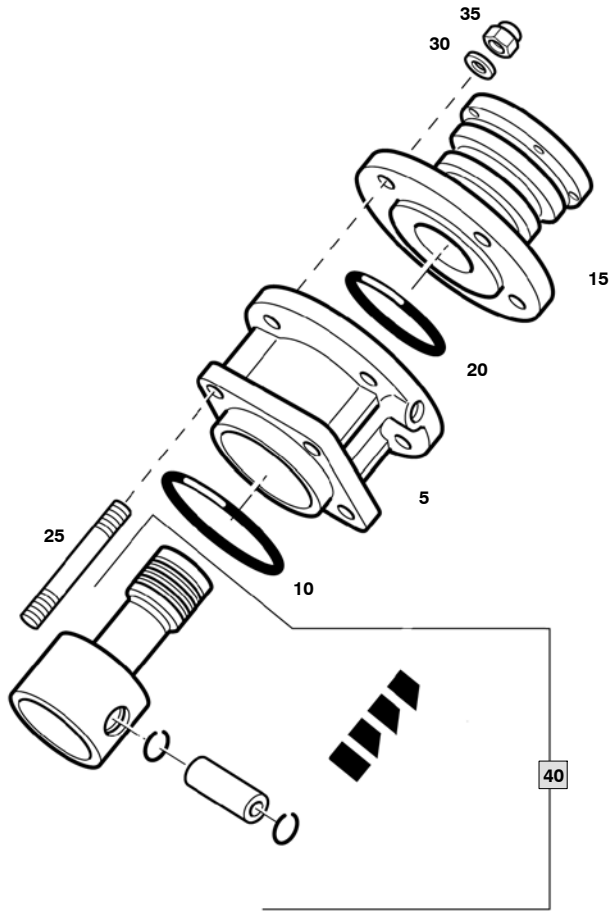

Wartungssätze
Maintenance sets
Kits d'entretien

Baugruppe 062899 Zylinder
Assembly 062899 Cylinder
Assemblage 062899 Cylindre

TUCM-4

Klasse/ Class/ Classe			Pos.	Bestell-Nr. Part No. No. de cde.	Anz. Qty. Qté.	Benennung	Designation	Dénomination
a	b	c						
			5	80383	1	Führungszylinder	guide cylinder	cylindre guide
		X	10	N2640	1	O-Ring	o-ring	joint torique
			15	62477	1	Zylinder	cylinder	cylindre
		X	20	N7063	1	O-Ring	o-ring	joint torique
			25	N2790	4	Stiftschraube	stud	goujon fileté
			30	N58	4	Scheibe	washer	rondelle
		X	35	N370	4	Selbstsichernde Mutter	hexagon nut self-locking	écrou hexagonal auto-fr
			40	072249	1	Kolben kpl.	piston cpl.	piston cpl.

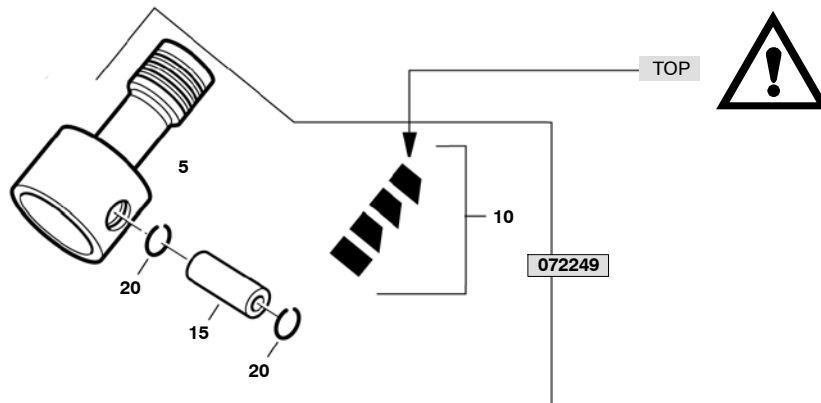

Wartungssätze
 Maintenance sets
 Kits d'entretien

Baugruppe 072249 Kolben kpl.
Assembly 072249 Piston cpl.
Assemblage 072249 Piston cpl.

TUCM-4a

Klasse/ Class/ Classe			Pos.	Bestell-Nr. Part No. No. de cde.	Anz. Qty. Qté.	Benennung	Designation	Dénomination
0	2	5						
			5	62487	1	Kolben	piston	piston
			10	N2647	1	Kolbenringsatz	piston ring set	jeu de segments
			15	N1429	1	Kolbenbolzen	piston pin	axe de piston
			20	N484	2	Sicherungsring	circlip ring	rondelle de sûreté

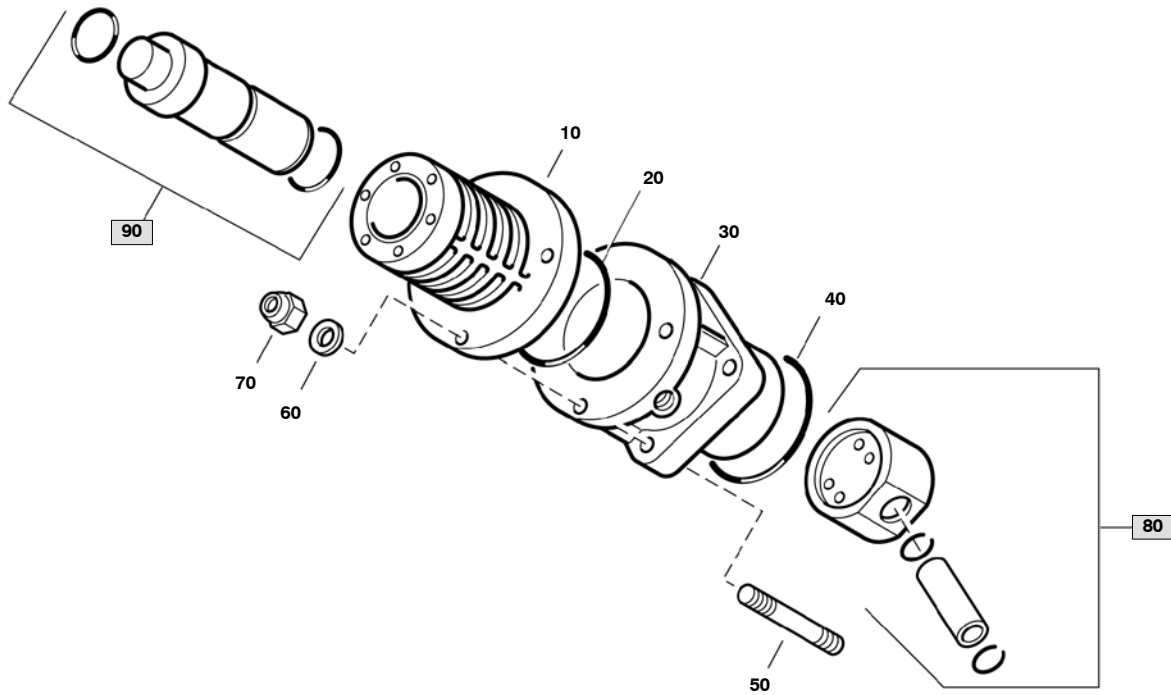

Wartungssätze
Maintenance sets
Kits d'entretien

Baugruppe 078042 Zylinder 3. Stufe
Assembly 078042 Cylinder 3rd stage
Assemblage 078042 Cylindre 3e étage

TUCM-5

Klasse/ Class/ Classe			Pos.	Bestell-Nr. Part No. No. de cde.	Anz. Qty. Qté.	Benennung	Designation	Dénomination
a	b	c						
			10	76754	1	Zylinder	cylinder	cylindre
		X	20	N7063	1	O-Ring	o-ring	joint torique
			30	80381	1	Führungszylinder	guide cylinder	cylindre de guidage
		X	40	N2640	1	O-Ring	o-ring	joint torique
			50	N2790	4	Stiftschraube	stud	goujon fileté
			60	N58	4	Scheibe	washer	rondelle
		X	70	N370	4	Sechskantmutter	hexagon nut self-locking	écrou hexagonal auto-fr.
			80	072165	1	Kolben kpl.	piston cpl.	piston cpl.
X			90	078043	1	Kolbenbüchse kpl.	sleeve	douille

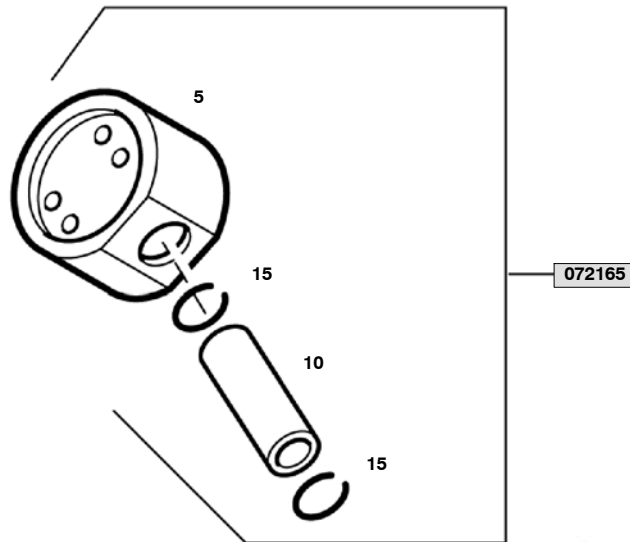

Wartungssätze
Maintenance sets
Kits d'entretien

Baugruppe 072165 Kolben kpl.
Assembly 072165 Piston cpl.
Assemblage 072165 Piston cpl.

TUCM-5a

Klasse/ Class/ Classe			Pos.	Bestell-Nr. Part No. No. de cde.	Anz. Qty. Qté.	Benennung	Designation	Dénomination
0	2	5						
			5		1	Führungskolben	guide piston	piston guide
			10		1	Kolbenbolzen	piston pin	coussinet
			15	N484	2	Sicherungsring	circlip ring	rondelle de sûreté

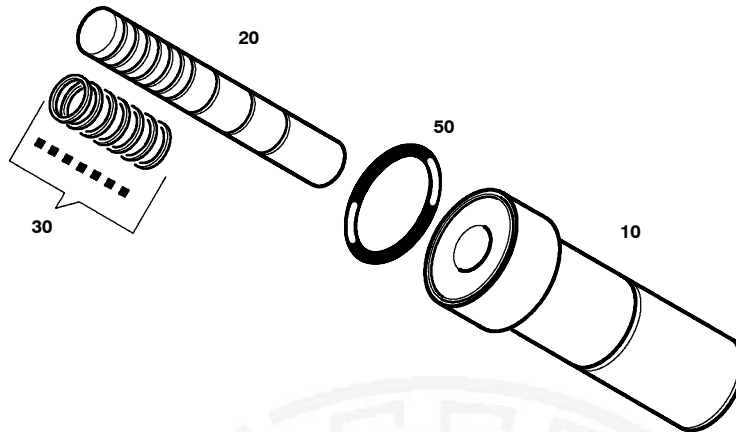

Wartungssätze
Maintenance sets
Kits d'entretien

Baugruppe 078043 Kolbenbüchse kpl.
Assembly 078043 Piston and sleeve
Assemblage 078043 Douille de piston

TUCM-5b

Klasse/ Class/ Classe			Pos.	Bestell-Nr. Part No. No. de cde.	Anz. Qty. Qté.	Benennung	Designation	Dénomination
a	b	c						
			10	*	1	Kolbenbüchse	Piston liner	douille de piston
			20	*	1	Kolben	Piston	Piston
			30	*	1	Kolbenringsatz	Pistonring set	Jeu des segments
X			50	N23755	1	O-Ring	o-ring	joint torique

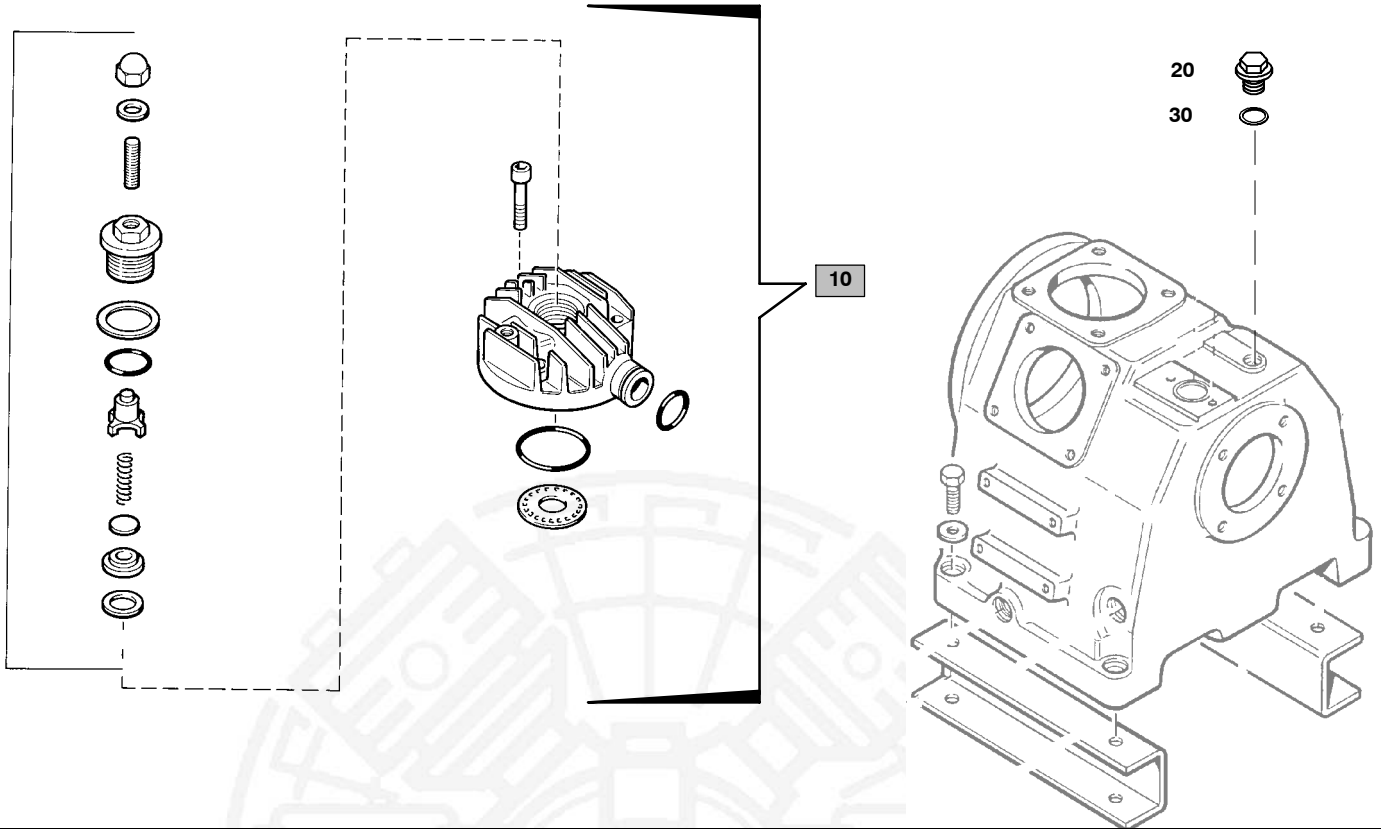

Wartungssätze
Maintenance sets
Kits d'entretien

Baugruppe 81632 Ventilkopf 1. Stufe
Assembly 81632 Valve head 1st stage
Assemblage 81632 Culasse 1er étage

TUCM-6

Klasse/ Class/ Classe			Pos.	Bestell-Nr. Part No. No. de cde.	Anz. Qty. Qté.	Benennung	Designation	Dénomination
a	b	c						
			10	069951	1	Ventilkopf kpl.	valve head assy.	culasse cpl.
X			20	N314	1	Verschlusschraube	plug	bouchon fileté
			30	N293	1	Dichtring	gasket	joint

IK100 II

BAUER
KOMPRESSOREN

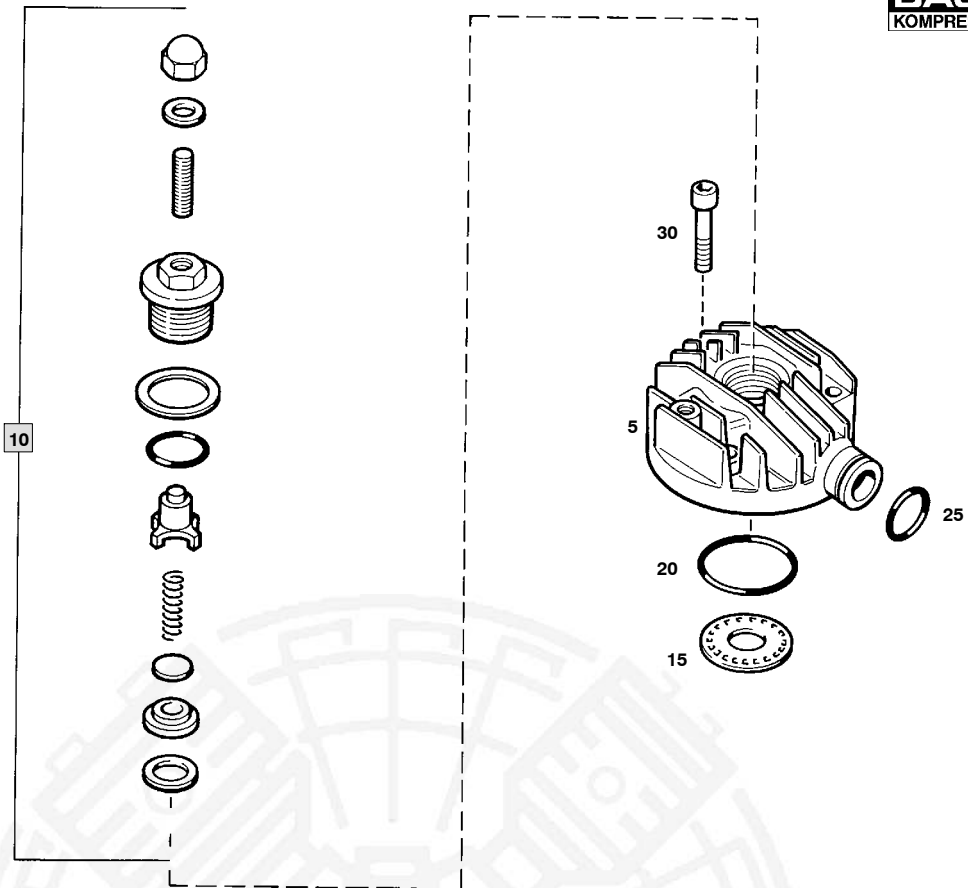

Wartungssätze
Maintenance sets
Kits d'entretien

Baugruppe 069951 Ventilkopf 1. Stufe
Assembly 069951 Valve head 1st stage
Assemblage 069951 Culasse 1er étage

TUCM-6a

Klasse/ Class/ Classe			Pos.	Bestell-Nr. Part No. No. de cde.	Anz. Qty. Qté.	Benennung	Designation	Dénomination
a	b	c						
			5	14907	1	Ventilkopf	valve head	culasse
			10	014583	1	Druckventil kpl.	pressure valve	soupape de compression
	X		15	9884	1	Saugventilplatte	suction valve plate	clapet d'aspiration
X			20	N2169	1	O-Ring	o-ring	joint torique
			25	N1539	1	O-Ring	o-ring	joint torique
			30	N503	3	Zylinderschraube	allen screw	vis à six pans creux

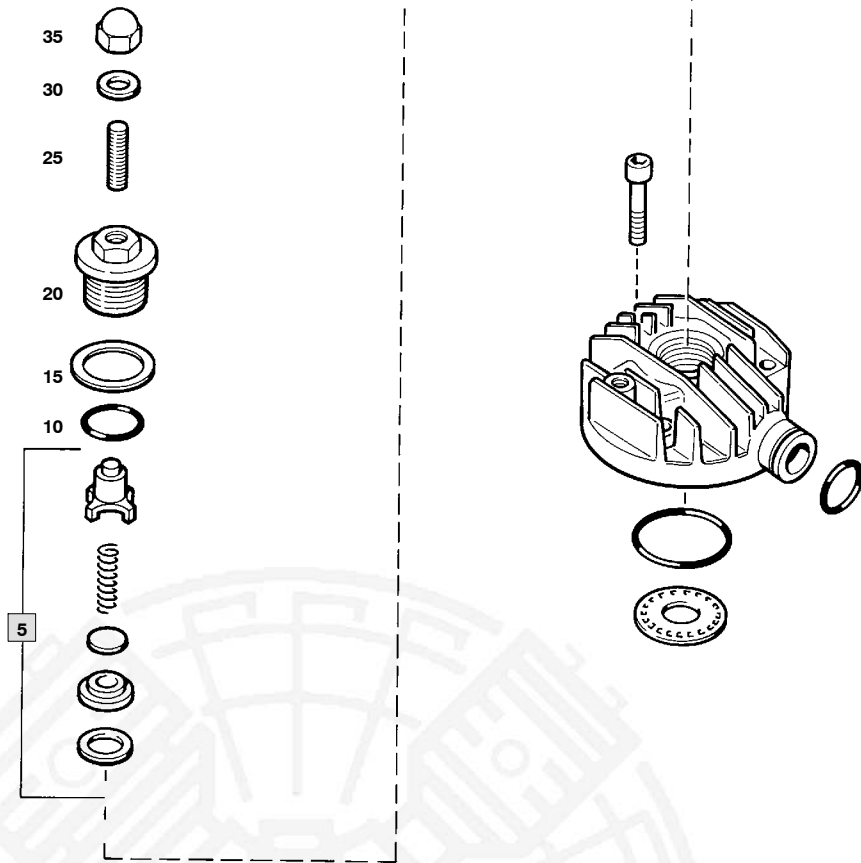

Wartungssätze
Maintenance sets
Kits d'entretien

Baugruppe 014583 Druckventil kpl.
Assembly 014583 Pressure valve
Assemblage 014583 Soupape de compression

TUCM-6b

Klasse/ Class/ Classe			Pos.	Bestell-Nr. Part No. No. de cde.	Anz. Qty. Qté.	Benennung	Designation	Dénomination
a	b	c						
	X		5	012840	1	Druckventileinsatz kpl.	pressure valve insert	soupape de pression
X			10	N3521	1	O-Ring	o-ring	joint torique
			15	14332	1	Tellerfeder	spring washer	rondelle-ressort
			20	14124	1	Verschraubung	coupling	raccord
	X		25	71064	1	Gewindestift	stud	goujon fileté
X			30	N380	1	Dichtung	gasket	joint
			35	N84	1	Sechskant-Hutmutter	acorn nut	écrou borgne

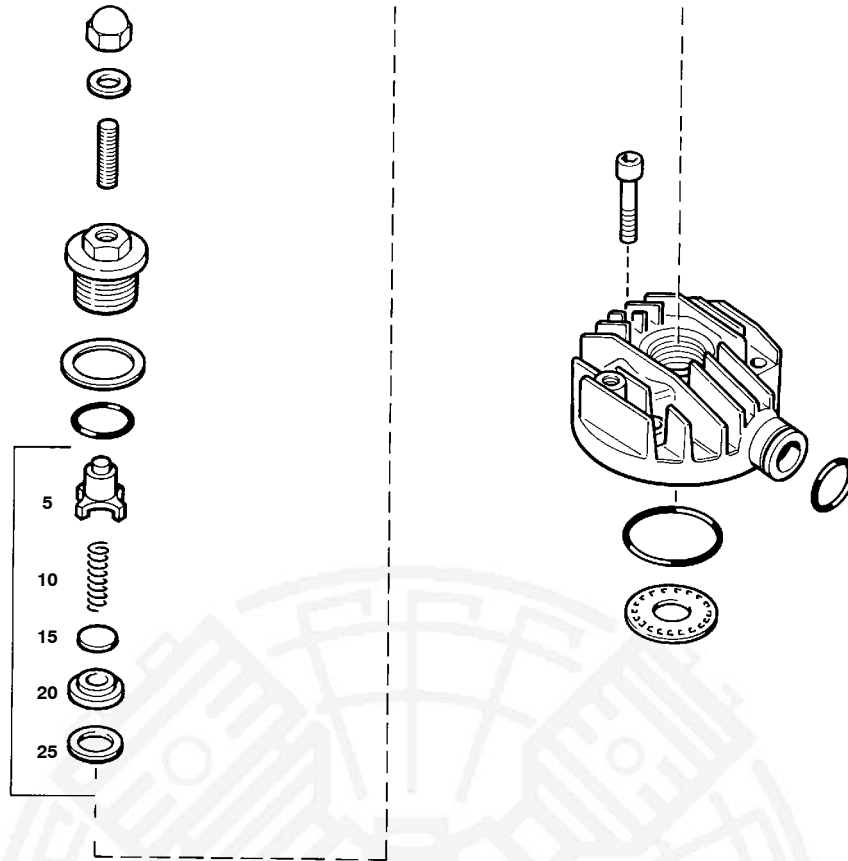

Wartungssätze
Maintenance sets
Kits d'entretien

Baugruppe 012840 Druckventileinsatz kpl.
Assembly 012840 Pressure valve insert
Assemblage 012840 Soupape de compression

TUCM-6c

Klasse/ Class/ Classe			Pos.	Bestell-Nr. Part No. No. de cde.	Anz. Qty. Qté.	Benennung	Designation	Dénomination
a	b	c						
			5		1	Druckventileinsatz	pressure valve insert	soupape de pression
			10	1026	1	Ventilfeder	valve spring	ressort de soupape
			15		1	Ventilplatte	valve plate	plaque de soupape
			20		1	Ventilsitz	valve seat	siège de soupape
X			25	240	1	Dichtung	gasket	joint

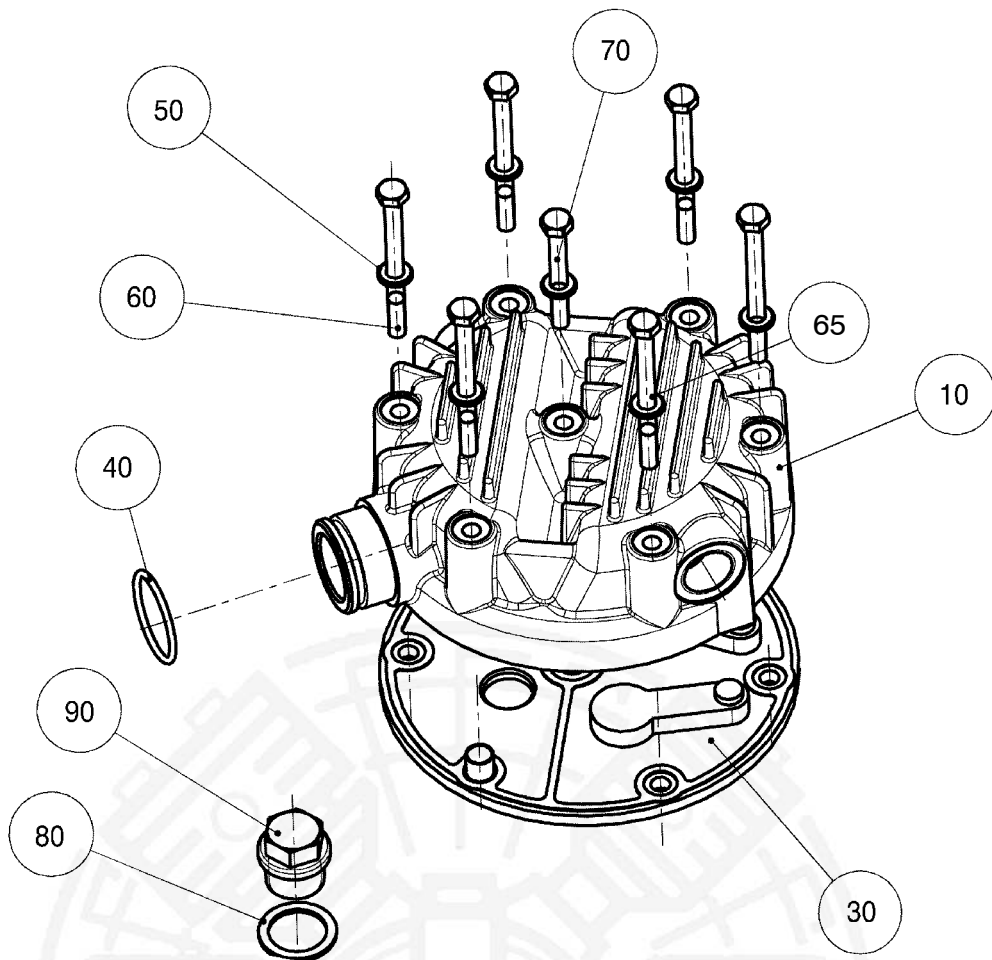

Wartungssätze
Maintenance sets
Kits d'entretien

Baugruppe 83652
Assembly 83652
Assemblage 83652

Ventilkopf 1. Stufe
Valve head 1st stage
Culasse 1er étage

TUCM-7

Klasse/ Class/ Classe			Pos.	Bestell-Nr. Part No. No. de cde.	Anz. Qty. Qté.	Benennung	Designation	Dénomination
a	b	c						
			5	80677	1	Ventilkopf	valve head	culasse
			30	N26531	1	Lamellenventil	reed valve	soupape à lamelles
			40	N1539	1	O-Ring	o-ring	joint torique
			50	N102	1	Scheibe	washer	rondelle
			60	N26568	4	Sechskantschraube	hex. screw	vis six pans
			65	N26568	4	Sechskantschraube	hex. screw	vis six pans
			70	N28108	2	Sechskantschraube	hex. screw	vis six pans
			80	N293	1	Dichtring	gasket	joint
			90	N314	1	Verschußschraube	plug	bouchon

IK12.4 II
 IK100 II
 IK120 II

BAUER
 KOMPRESSOREN

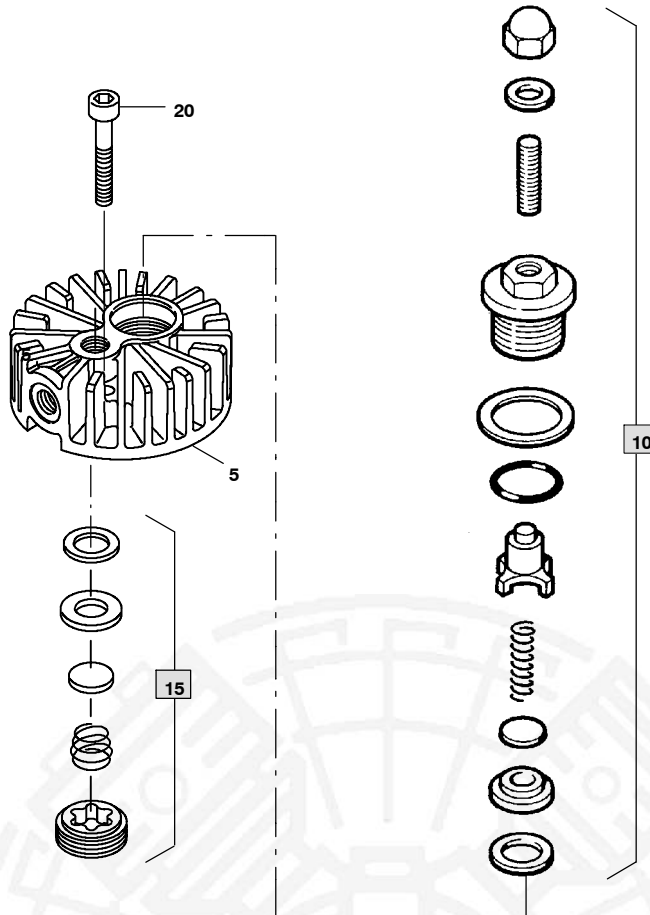

Wartungssätze
 Maintenance sets
 Kits d'entretien

Baugruppe 069955 Ventilkopf
 Assembly 069955 Valve head
 Assemblage 069955 Culasse

TUCM-8

Klasse/ Class/ Classe			Pos.	Bestell-Nr. Part No. No. de cde.	Anz. Qty. Qté.	Benennung	Designation	Dénomination
a	b	c						
			5	14123	1	Ventilkopf	valve head	culasse
			10	014582	1	Druckventil kpl.	discharge valve assy.	soupape de pression
	X		15	012841	1	Saugventil	intake valve	soupape d'aspiration
			20	N503	6	Zylinderschraube	allen screw	vis à six pans creux

IK12.4 II
 IK100 II
 IK120 II

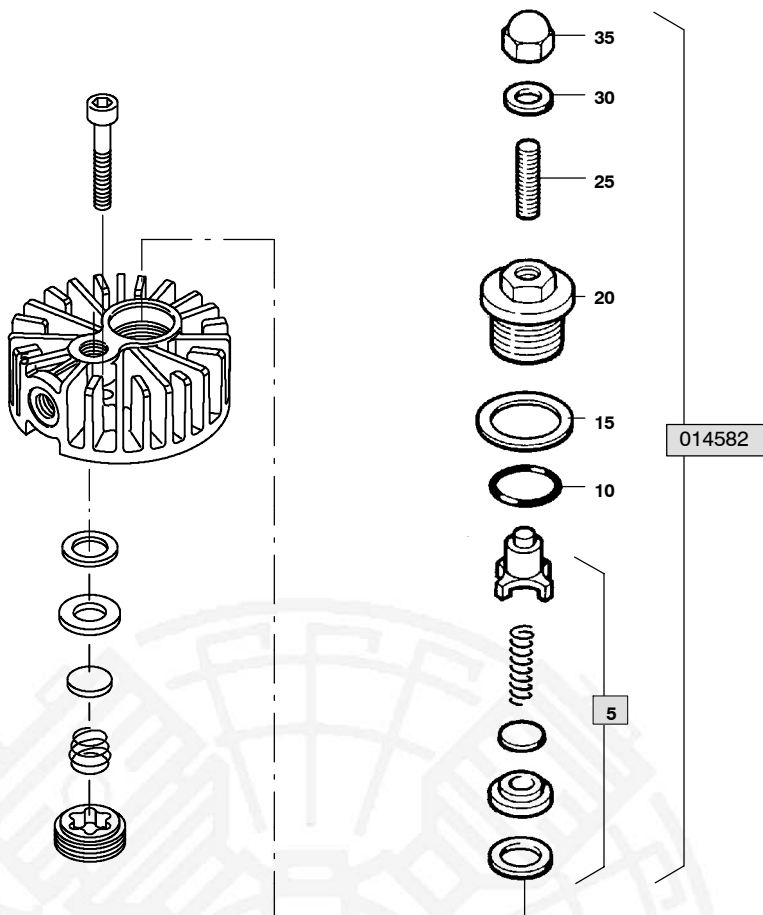

Wartungssätze
 Maintenance sets
 Kits d'entretien

Baugruppe 014582
 Assembly 014582
 Assemblage 014582

Druckventil kpl.
 Pressure valve assy.
 Soupape de compression cpl.

TUCM-8a

Klasse/ Class/ Classe			Pos.	Bestell-Nr. Part No. No. de cde.	Anz. Qty. Qté.	Benennung	Designation	Dénomination
a	b	c						
	X		5	012835	1	Druckventileinsatz kpl.	discharge valve insert	soupape de pression
X			10	N3521	1	O-Ring	o-ring	joint torique
			15	14332	1	Tellerfeder	spring washer	rondelle-ressort
			20	14124	1	Verschraubung	coupling	raccord
	X		25	71064	1	Gewindestift	stud	goujon fileté
X			30	N3625	1	Dichtung	gasket	joint
			35	N84	1	Sechskant-Hutmutter	acorn nut	écrou borgne

IK12.4 II
 IK100 II
 IK120 II

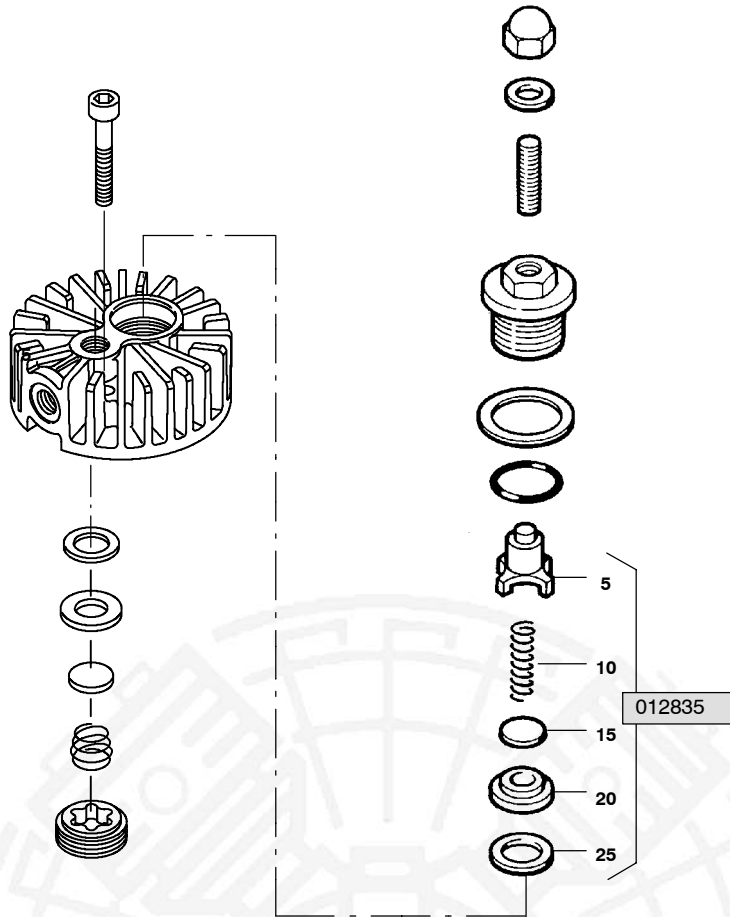

Wartungssätze
 Maintenance sets
 Kits d'entretien

Baugruppe 012835 Druckventileinsatz kpl.
Assembly 012835 Pressure valve insert assy
Assemblage 012835 Soupape de compression cpl.

TUCM-8b

Klasse/ Class/ Classe			Pos.	Bestell-Nr. Part No. No. de cde.	Anz. Qty. Qté.	Benennung	Designation	Dénomination
a	b	c						
			5		1	Druckventileinsatz	discharge valve insert	soupape de pression
			10	1026	1	Ventilfeder	valve spring	ressort de soupape
			15		1	Ventilplatte	valve plate	clapet
			20		1	Ventilsitz	valve seat	siège de soupape
X			25	240	1	Dichtung	gasket	joint

IK12.4 II
 IK100 II
 IK120 II

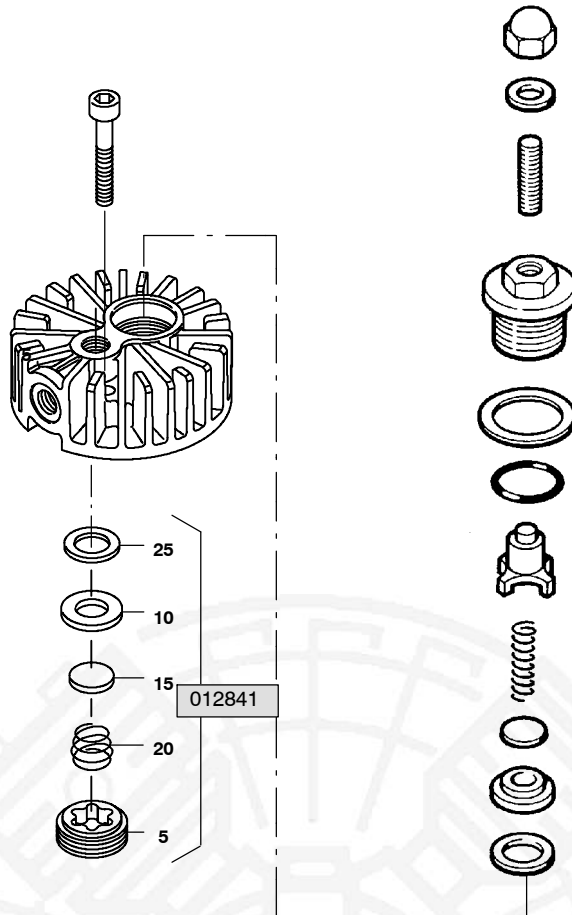

Wartungssätze
 Maintenance sets
 Kits d'entretien

Baugruppe 012841 **Saugventil**
Assembly 012841 **Intake valve**
Assemblage 012841 **Soupape d'aspiration**

TUCM-8c

Klasse/ Class/ Classe			Pos.	Bestell-Nr. Part No. No. de cde.	Anz. Qty. Qté.	Benennung	Designation	Dénomination
a	b	c						
			5		1	Ventilverschraubung	valve cover	cage de soupape
			10		1	Ventilsitz	valve seat	siège de soupape
			15		1	Ventilplatte	valve plate	clapet
			20		1	Druckfeder	pressure spring	ressort de pression
X			25	240	1	Dichtung	gasket	joint

BK12.2 II
BK15.3 II
BK15.4 II
IK12.4 II
IK12.14 II
IK100 II
IK120 II

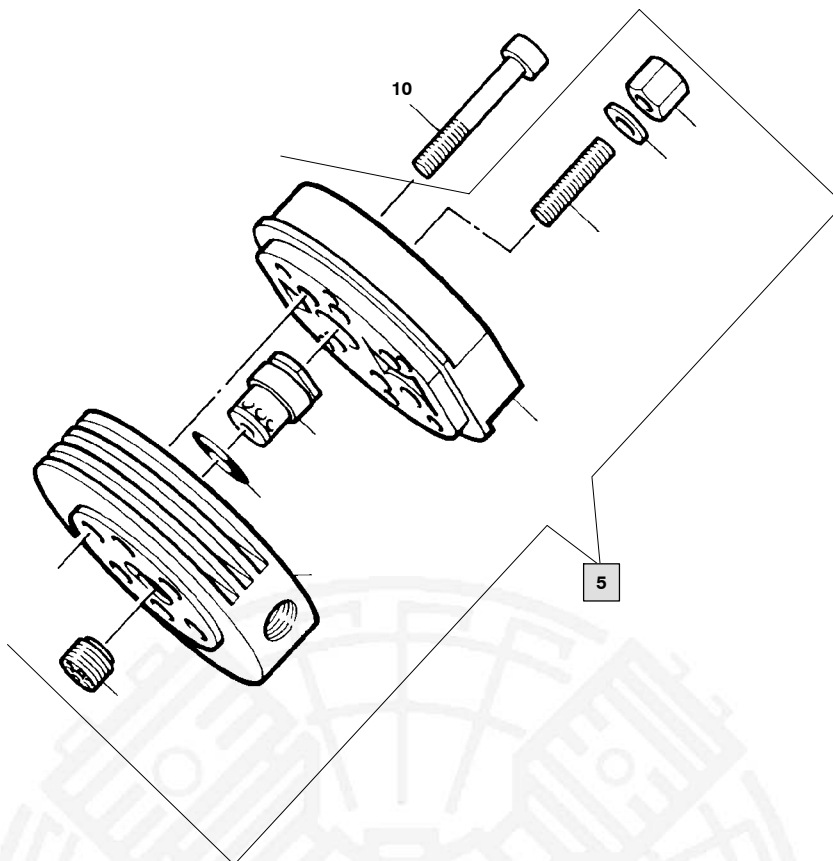

068607/12/948



Wartungssätze
 Maintenance sets
 Kits d'entretien

Baugruppe 068607 Ventilkopf
Assembly 068607 Valve head
Assemblage 068607 Culasse

TUCM-9

Klasse/ Class/ Classe			Pos.	Bestell-Nr. Part No. No. de cde.	Anz/ Qty/ Qté	Benennung	Designation	Dénomination
a	b	c						
			5	073629	1	Ventilkopf	valve head	culasse
			10	N1282	6	Zylinderschraube	allen screw	vis à six pans creux

BK12.2 II
BK15.3 II
BK15.4 II
IK12.4 II
IK12.14 II
IK100 II
IK120 II

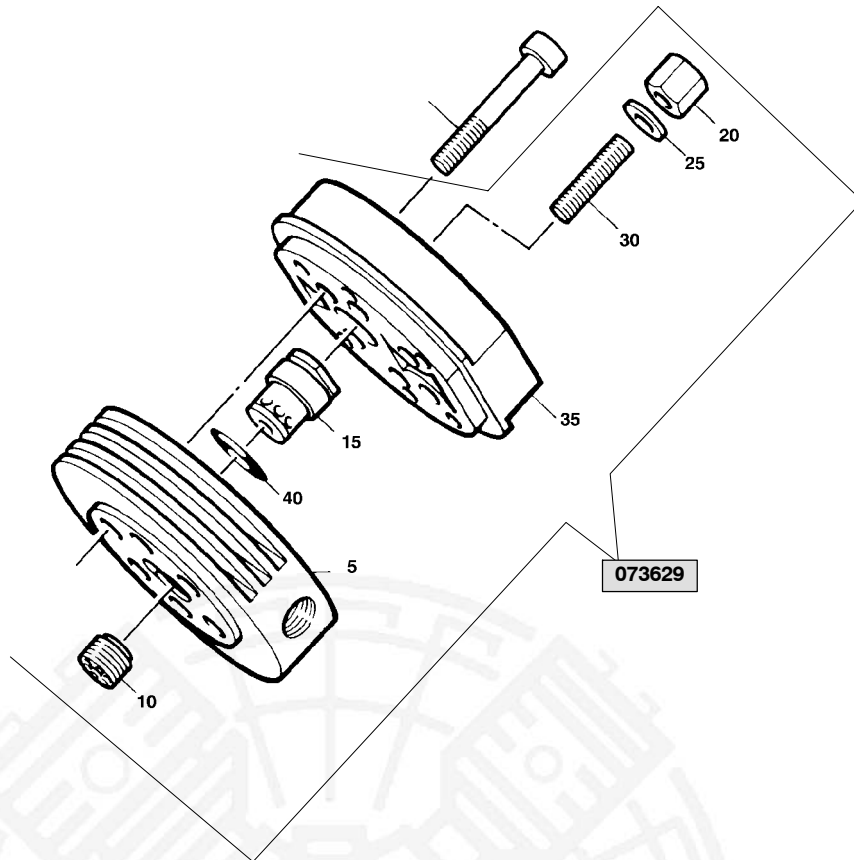

073629/12/98



Wartungssätze
 Maintenance sets
 Kits d'entretien

Baugruppe 073629 Ventilkopf
Assembly 073629 Valve head
Assemblage 073629 Culasse

TUCM-9a

Klasse/ Class/ Classe			Pos.	Bestell-Nr. Part No. No. de cde.	Anz/ Qty/ Qté	Benennung	Designation	Dénomination
a	b	c						
			5	65191	1	Ventilkopf	valve head	culasse
	X		10	81409	1	Saugventil	suction valve	clapet d'aspiration
	X		15	014121	1	Druckventil	pressure valve	soupape de pression
			20	N3623	1	Sechskant-Hutmutter	acorn nut	écrou borgne
X			25	N3625	1	Dichtring	gasket	joint
	X		30	71065	1	Gewindestift	stud	goujon fileté
			35	14118	1	Ventilkopf-Deckel	valve head cover	couvercle de culasse
			40	N2789	1	O-Ring	o-ring	joint torique

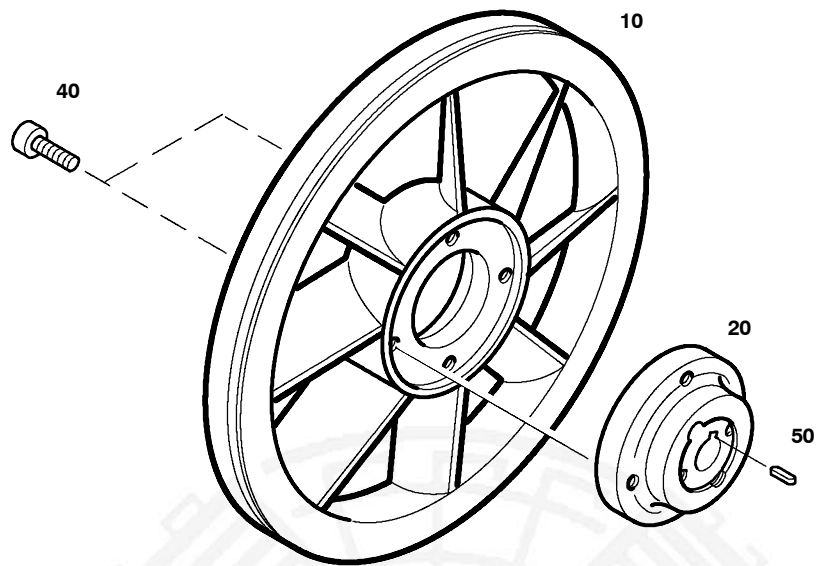
 Wartungssätze
 Maintenance sets
 Kits d'entretien

Baugruppe 076251 Schwungrad
Assembly 076251 Flywheel
Assemblage 076251 Volant-ventilateur
TUCM-10

Klasse/ Class/ Classe			Pos.	Bestell-Nr. Part No. No. de cde.	Anz. Qty. Qté.	Benennung	Designation	Dénomination
a	b	c						
			10	76217	1	Ventilatorrad	fanwheel	ventilateur
			20	76211	1	Ventilatorradnabe	fanwheel hub	moyeu de ventilateur
			40	N61	4	Zylinderschraube	allen screw	vis à six pans creux
			50	N1386	1	Paßfeder	feather key	ressort d'ajustage

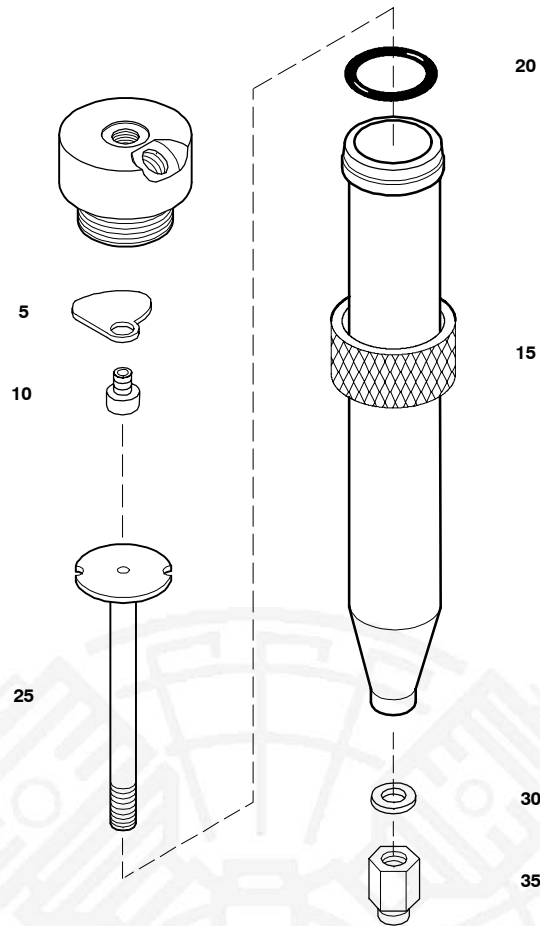

 Wartungssätze
 Maintenance sets
 Kits d'entretien

Baugruppe 81799
Assembly 81799
Assemblage 81799
Zwischenfilter
Inter filter
Filtre intermédiaire
TUCM-11

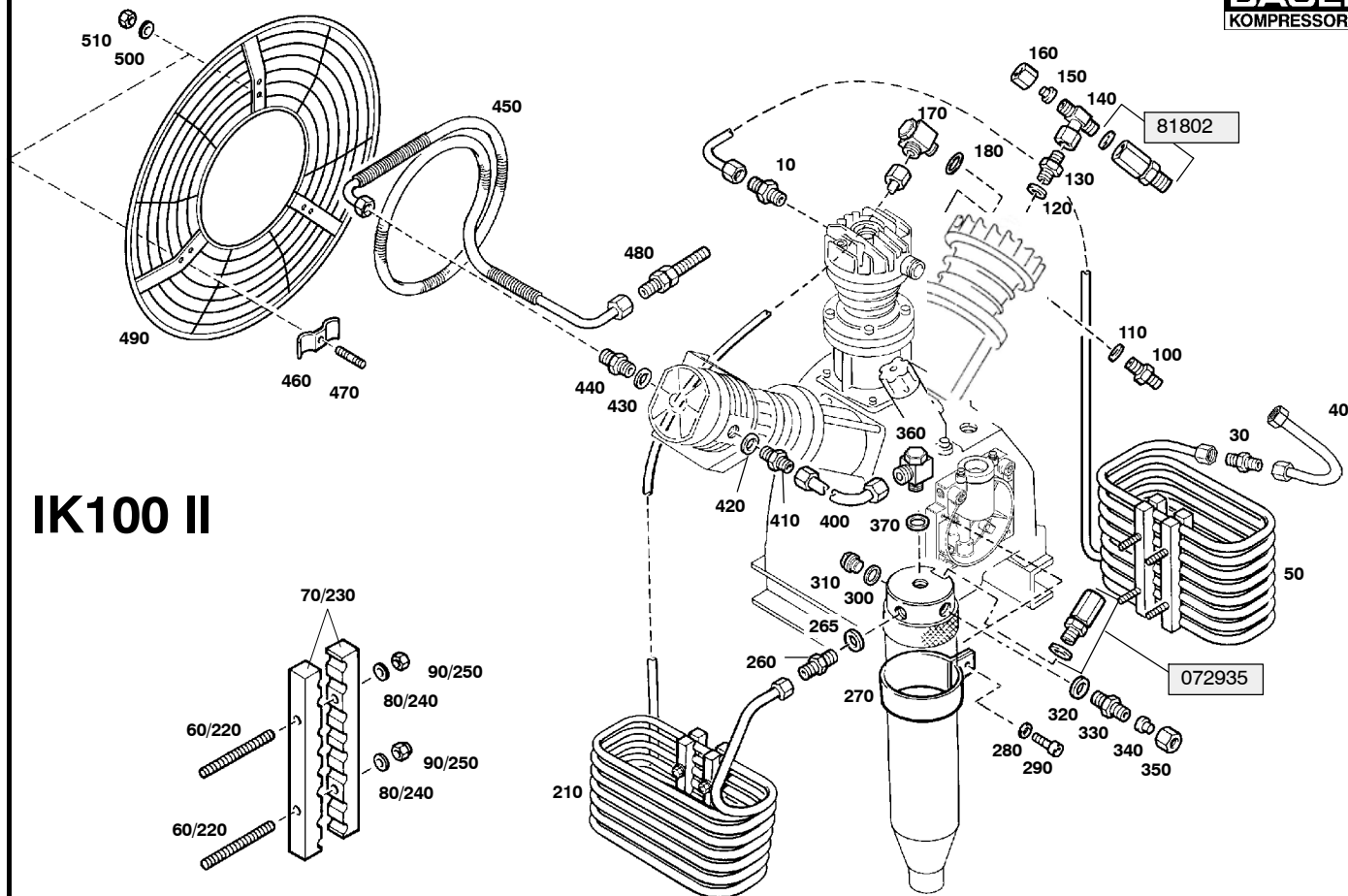
Klasse/ Class/ Classe			Pos.	Bestell-Nr. Part No. No. de cde.	Anz/ Qty/ Qté	Benennung	Designation	Dénomination
a	b	c						
			5	81148	1	Blech	plate	plaque
			10	81643	1	Hohlschraube	hollow screw	vis creuse
			15	13937	1	Überwurfmutter	screw cap	écrou borgne
X			20	N3556	1	O-Ring	o-ring	joint torique
			25	76613	1	Einschraubteil kpl.	insert assy.	pièce à visser cpl.
			30	N1316	1	Dichtung	gasket	joint
			35	N20215	1	Ger. Aufschraubst.	male fitting	manchon mâle

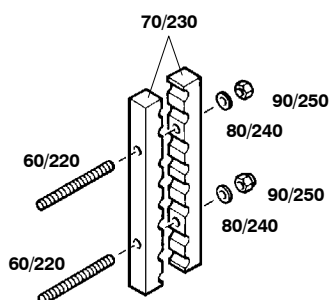

IK100 II



Wartungssätze
 Maintenance sets
 Kits d'entretien

Baugruppe 81292
Assembly 81292
Assemblage 81292

Kühlung IK100 II
Cooling system IK100 II
Refroidissement IK100 II

TUCM-12

Klasse/ Class/ Classe			Pos.	Bestell-Nr. Part No. No. de cde.	Anz. Qty. Qté.	Benennung	Designation	Dénomination
a	b	c						
			10	N20189	1	G-Einschraubstutzen	male connector	raccord droit mâle
			30	N20310	1	G-Einschraubstutzen	male connector	raccord droit mâle
			40	81297	1	Verbindungsleitung kpl.	connecting tube assy.	conduite de liaison cpl.
			50	79486	1	Zwischenkühler kpl.	intermediate cooler cpl.	refroidisseur interméd.
			60	N3494	4	Stiftschraube	stud	goujon fileté
			70	62773	4	Fixierung	fixing for cooler	fixation de refroidisseur
			80	N102	4	Scheibe	washer	rondelle
			90	N1042	4	Sechskantmutter	hexagon nut self-locking	écrou hexagonal auto-fr
			100	N20059	1	G-Einschraubstutzen	fitting	raccord droit mâle
			110	N1316	1	Dichtring	gasket	joint
			120	N1316	1	Dichtring	gasket	joint
			130	N20195	1	G-Einschraubstutzen	male connector	raccord droit mâle
			140	N20019	1	Einst. T-Stutzen	adjustable T connector	raccord T mâle
			150	N4530	1	Verschlußstopfen	plug	bouchon
			160	N3610	1	Überwurfmutter	screw cap 6S	écrou borgne
			170	N26751	1	Schwenkstutzen	coupling	raccord
			180	N1316	1	Dichtring	gasket	joint
			210	78195	1	Zwischenkühler kpl.	intercooler	refroidisseur interméd.
			220	N3494	4	Stiftschraube	stud	goujon fileté
			230	62773	4	Fixierung	fixing for cooler	fixation de refroidisseur
			240	N102	4	Scheibe	washer	rondelle
			250	N1042	4	Sechskantmutter	hexagon nut self-locking	écrou hexagonal auto-fr
			260	N20059	1	G-Einschraubstutzen	fitting	raccord
			265	N1316	1	Dichtring	gasket	joint
			270	77894	2	Rohrschelle	clamp	collier

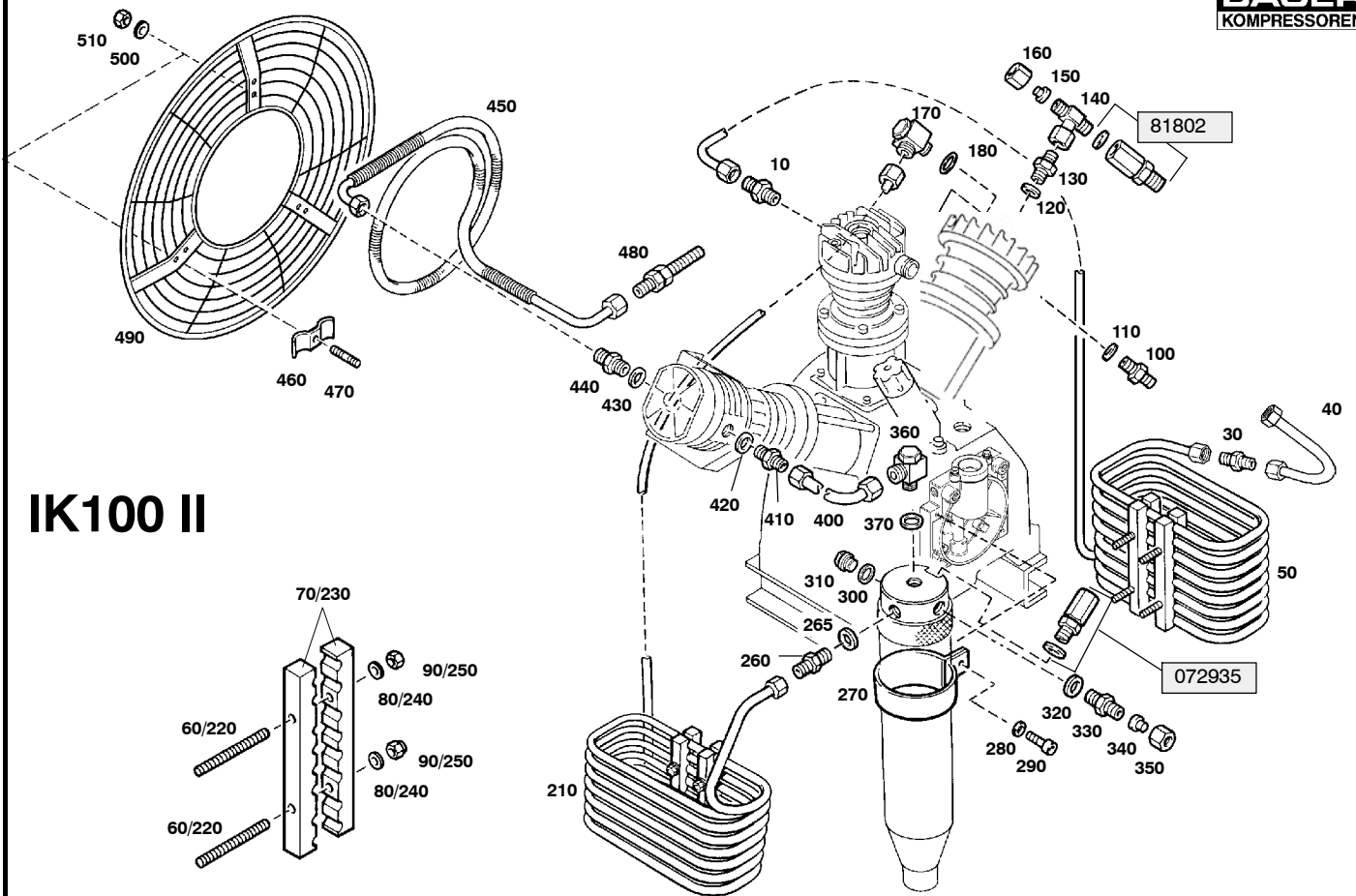

IK100 II



Wartungssätze
 Maintenance sets
 Kits d'entretien

Baugruppe 81292
Assembly 81292
Assemblage 81292

Kühlung IK100 II
Cooling system IK100 II
Refroidissement IK100 II

TUCM-12

Klasse/ Class/ Classe			Pos.	Bestell-Nr. Part No. No. de cde.	Anz. Qty. Qté.	Benennung	Designation	Dénomination
a	b	c						
			280	N2460	2	Scheibe	washer	rondelle
			290	N88	2	Sechskantschraube	hexagon screw	vis hexagonale
			300	N1316	1	Dichtring	gasket	joint
			310	N52	1	Verschlußschraube	plug	bouchon fileté
			320	N1316	1	Dichtring	gasket	joint
			330	N20195	1	G-Einschraubstutzen	male connector	raccord droit mâle
			340	N4530	1	Verschlußstopfen	plug	bouchon
			350	N3610	1	Überwurfmutter	screw cap 6S	écrou borgne
			360	N26751	1	Schwenkstutzen	coupling	raccord
			370	N1316	1	Dichtring	gasket	joint
			400	78197	1	Verbindungsleitung kpl.	connecting tube assy.	conduite de liaison cpl.
			410	N20059	1	G-Einschraubstutzen	fitting	raccord
			420	N1316	1	Dichtring	gasket	joint
			430	56983	1	Dichtring	gasket	joint
			440	71148	1	Rohrverschraubung	connector	raccord
			450	070724	1	Nachkühler kpl.	after cooler cpl.	refroidisseur final cpl.
			460	11887	3	Schelle	double strap	collier double
			470	78199	3	Gewindestift	headless screw	vis sans tête
			480	N20183	1	G-Schottstutzen	connector	raccord
			490	78200	1	Lüfterradschutz	flywheel protector	protection du ventilateur
			500	N58	3	Scheibe	washer	rondelle
			510	N370	3	Sechskantmutter	hexagon nut self-locking	écrou hexagonal auto-fr

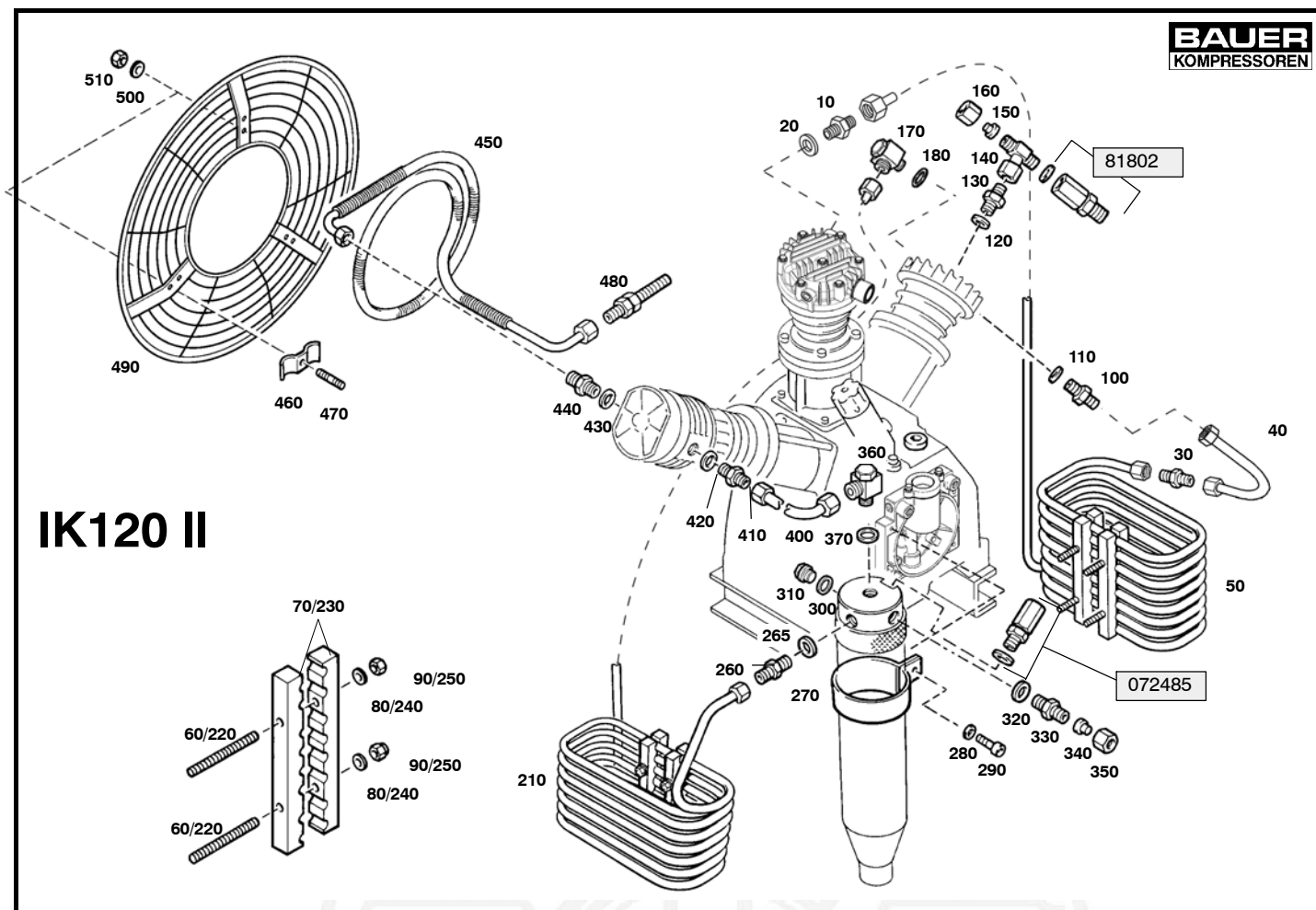

IK120 II

 Wartungssätze
 Maintenance sets
 Kits d'entretien

Baugruppe 81293
Assembly 81293
Assemblage 81293
Kühlung IK120 II
Cooling system IK120 II
Refroidissement IK120 II

TUCM-13

Klasse/ Class/ Classe			Pos.	Bestell-Nr. Part No. No. de cde.	Anz. Qty. Qté.	Benennung	Designation	Dénomination
a	b	c						
			10	N20294	1	G-Einschraubstutzen	male connector	raccord droit mâle
			20	N293	1	Dichtring	gasket	joint
			30	N20310	1	G-Einschraubstutzen	male connector	raccord droit mâle
			40	81297	1	Verbindungsleitung kpl.	connecting tube assy.	conduite de liaison cpl.
			50	81309	1	Zwischenkühler kpl.	intermediate cooler cpl.	refroidisseur interméd.
			60	N3494	4	Stiftschraube	stud	goujon fileté
			70	62773	4	Fixierung	fixing for cooler	fixation de refroidisseur
			80	N102	4	Scheibe	washer	rondelle
			90	N1042	4	Sechskantmutter	hexagon nut self-locking	écrou hexagonal auto-fr
			100	N20059	1	G-Einschraubstutzen	fitting	raccord droit mâle
			110	N1316	1	Dichtring	gasket	joint
			120	N1316	1	Dichtring	gasket	joint
			130	N20195	1	G-Einschraubstutzen	male connector	raccord droit mâle
			140	N20019	1	Einst. T-Stutzen	adjustable T connector	raccord T mâle
			150	N4530	1	Verschlußstopfen	plug	bouchon
			160	N3610	1	Überwurfmutter	screw cap 6S	écrou borgne
			170	N26751	1	Schwenkstutzen	coupling	raccord
			180	N1316	1	Dichtring	gasket	joint
			210	78195	1	Zwischenkühler kpl.	intercooler	refroidisseur interméd.
			220	N3494	4	Stiftschraube	stud	goujon fileté
			230	62773	4	Fixierung	fixing for cooler	fixation de refroidisseur
			240	N102	4	Scheibe	washer	rondelle
			250	N1042	4	Sechskantmutter	hexagon nut self-locking	écrou hexagonal auto-fr
			260	N20059	1	G-Einschraubstutzen	fitting	raccord
			265	N1316	1	Dichtring	gasket	joint

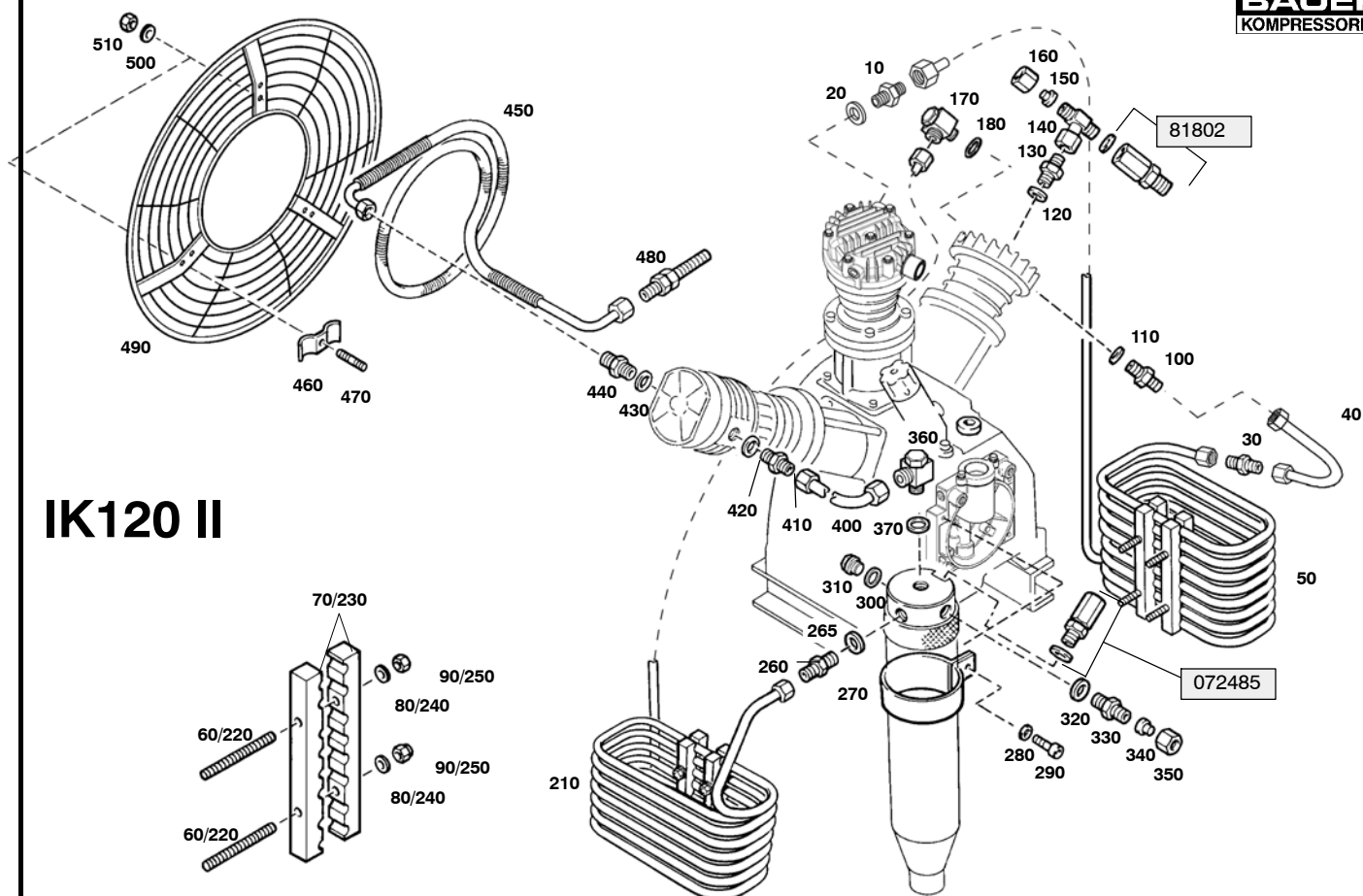

IK120 II

 Wartungssätze
 Maintenance sets
 Kits d'entretien

Baugruppe 81293
Assembly 81293
Assemblage 81293
Kühlung IK120 II
Cooling system IK120 II
Refroidissement IK120 II

TUCM-13

Klasse/ Class/ Classe			Pos.	Bestell-Nr. Part No. No. de cde.	Anz. Qty. Qté.	Benennung	Designation	Dénomination
a	b	c						
			270	77894	2	Rohrschelle	clamp	collier
			280	N2460	2	Scheibe	washer	rondelle
			290	N88	2	Sechskantschraube	hexagon screw	vis hexagonale
			300	N1316	1	Dichtring	gasket	joint
			310	N52	1	Verschlußschraube	plug	bouchon fileté
			320	N1316	1	Dichtring	gasket	joint
			330	N20195	1	G-Einschraubstutzen	male connector	raccord droit mâle
			340	N4530	1	Verschlußstopfen	plug	bouchon
			350	N3610	1	Überwurfmutter	screw cap 6S	écrou borgne
			360	N26751	1	Schwenkstutzen	coupling	raccord
			370	N1316	1	Dichtring	gasket	joint
			400	78197	1	Verbindungsleitung kpl.	connecting tube assy.	conduite de liaison cpl.
			410	N20059	1	G-Einschraubstutzen	fitting	raccord
			420	N1316	1	Dichtring	gasket	joint
			430	56983	1	Dichtring	gasket	joint
			440	71148	1	Rohrverschraubung	connector	raccord
			450	070724	1	Nachkühler kpl.	after cooler cpl.	refroidisseur final cpl.
			460	11887	3	Schelle	double strap	collier double
			470	78199	3	Gewindestift	headless screw	vis sans tête
			480	N20183	1	G-Schottstutzen	connector	raccord
			490	78200	1	Lüfterradschutz	flywheel protector	protection du ventilateur
			500	N58	3	Scheibe	washer	rondelle
			510	N370	3	Sechskantmutter	hexagon nut self-locking	écrou hexagonal auto-fr
			520	N1316	1	Dichtring	gasket	joint
			530	N20014	1	G-Einschraubstutzen	male connector	raccord droit mâle

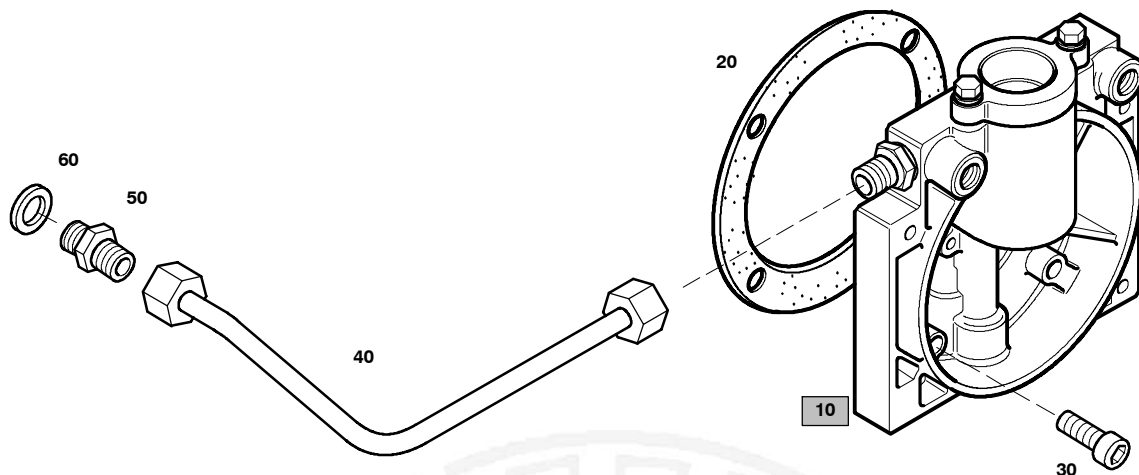
 Wartungssätze
 Maintenance sets
 Kits d'entretien

Baugruppe 81074
Assembly 81074
Assemblage 81074
Druckölschmierung kpl.
Lubricating system assy.
Lubrification cpl.
TUCM-14

Klasse/ Class/ Classe			Pos. .	Bestell-Nr. Part No. No. de cde.	Anz. Qty. Qté.	Benennung	Designation	Dénomination
a	b	c						
			10	81075	1	Druckölschmierung	lubricating system	système de lubrification
			20	78421	1	Dichtung	gasket	joint
			30	N503	4	Zylinderschraube	allen screw	vis allen
			40	81200	1	Verbindungsleitung kpl.	connecting tube assy.	conduite cpl.
			50	N20002	1	G-Einschraubstutzen	straight coupling	raccord mâle droit
			60	N4051	1	Dichtring	gasket	joint

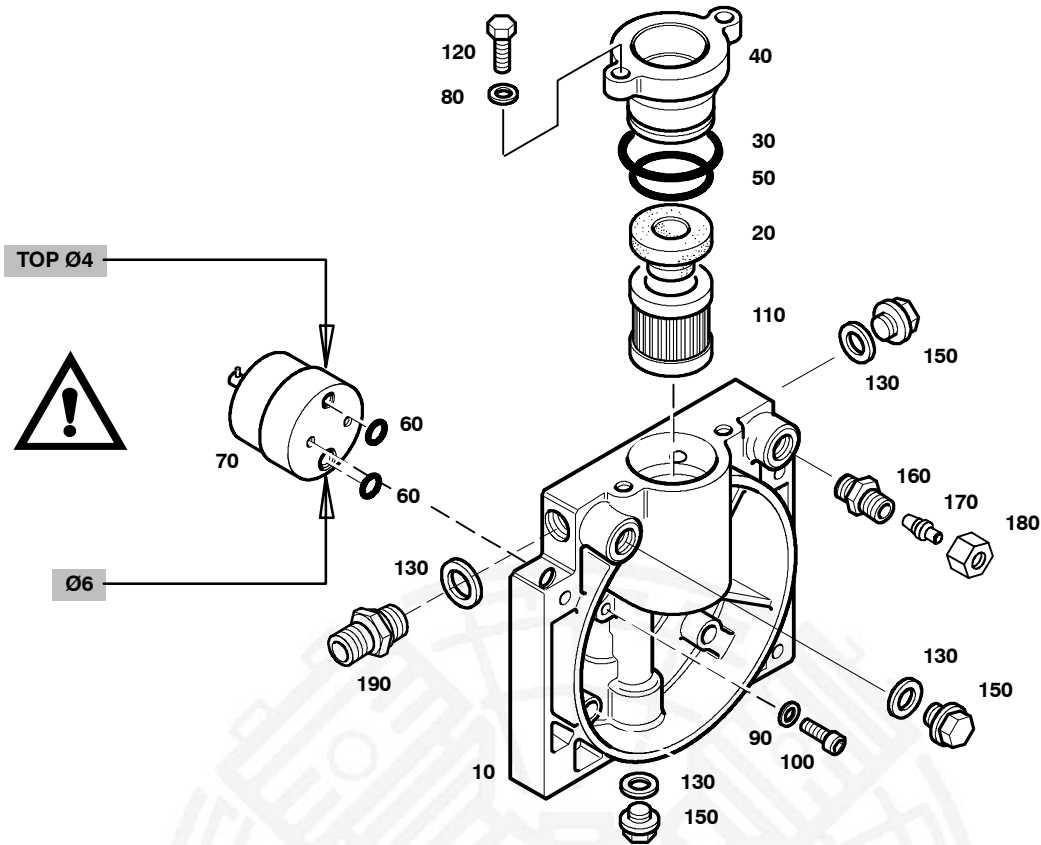
 Wartungssätze
 Maintenance sets
 Kits d'entretien

Baugruppe 81075
Assembly 81075
Assemblage 81075
Druckölschmierung
Lubricating system
Système de lubrification
TUCM-14a

Klasse/ Class/ Classe			Pos. .	Bestell-Nr. Part No. No. de cde.	Anz. Qty. Qté.	Benennung	Designation	Dénomination
a	b	c						
			10	77878	1	Deckel	cover plate	couvercle
			20	77774	1	Dichtung	gasket	joint
			30	N4058	1	O-Ring	o-ring	joint torique
			40	77885	1	Deckel	für Ölfilter	Deckel
			50	N25327	1	O-Ring	o-ring	joint torique
			60	N3489	2	O-Ring	o-ring	joint torique
			70	N24585	1	Zahnradpumpe	pump	pompe
			80	N58	2	Scheibe	washer	rondelle
			90	N2889	2	Dichtring	gasket	joint
			100	N25328	2	Zylinderschraube	allen screw	vis allen
			110	N25326	1	Filterelement	filter insert	élément filtrant
			120	N19506	2	Sechskantschraube	hex. screw	vis à six pans
			130	N1316	4	Dichtring	gasket	joint
			150	N52	3	Verschlußschraube	plug screw	bouchon
			160	N20065	1	G-Einschraubstutzen	coupling	raccord
			170	N16309	1	Verschlußstopfen	plug	bouchon
			180	N1049	1	Überwurfmutter	screw cap	écrou chapeau
			190	81050	1	Regulierventil	regulator valve	soupape de régulation

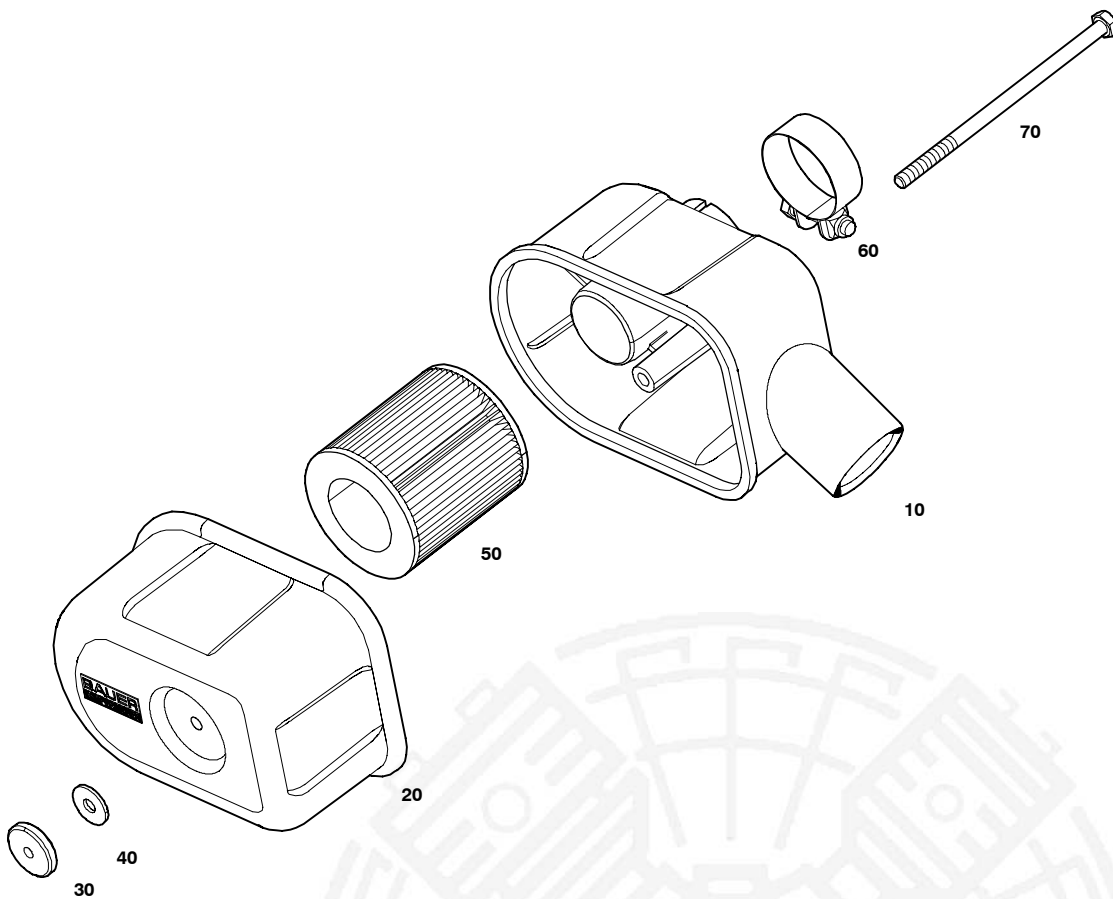
 Ersatzteilsätze
 Spare parts sets
 Kits de pièces dét.

Baugruppe 79577 **Ansaugfilter**
Assembly 79577 **Intake filter**
Assemblage 79577 **Filtre d'aspiration**
TUCM-15

Klasse/ Class/ Classe			Pos.	Bestell-Nr. Part No. No. de cde.	Anz. Qty. Qté.	Benennung	Designation	Dénomination
a	b	c						
			10	79575	1	Ansaugfilter-Gehäuse	intake filter housing	boîtier de filtre
			20	79574	1	Ansaugfilter-Deckel	suction filter cover	couvercle de filtre
			30	N4870	1	Rändelmutter	nut	écrou
			40	N3313	1	Scheibe	washer	rondelle
X			50	N25950	1	Filtereinsatz	filter insert	élément filtrant
			60	N3374	1	Schelle	clamp	collier
			70	N19502	1	Sechskantschraube	hex. screw	vis 6 pans

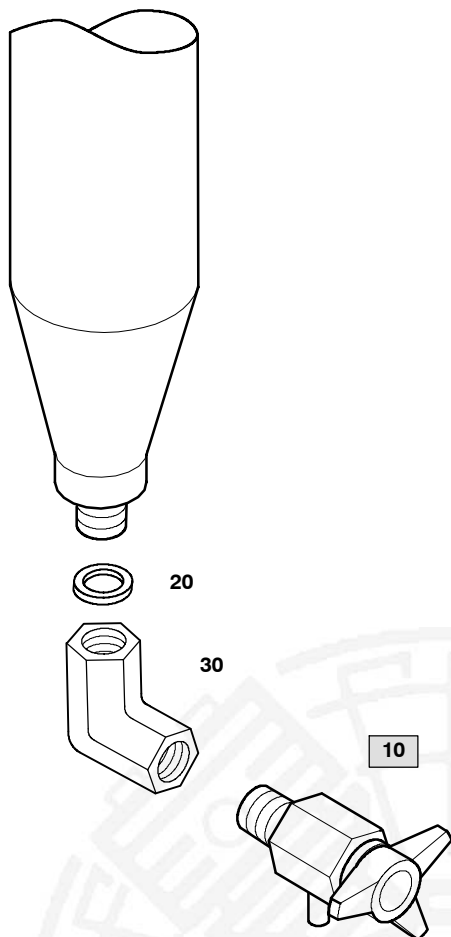
 Wartungssätze
 Maintenance sets
 Kits d'entretien

Baugruppe 81758
Assembly 81758
Assemblage 81758
Kondensatablaßhahn
Condensate drain tap
Robinet de purge
TUCM-16

Klasse/ Class/ Classe			Pos.	Bestell-Nr. Part No. No. de cde.	Anz. Qty. Qté.	Benennung	Designation	Dénomination
0	2	5						
			10	011430	1	Ablaßhahnkörper, kpl.	drain valve body	corps de robinet de purge
X			20	N19368	1	Dichtung	gasket	joint
			30	N26972	1	W-Verschraubung	elbow coupling	coude

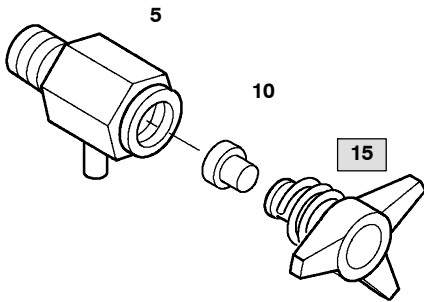
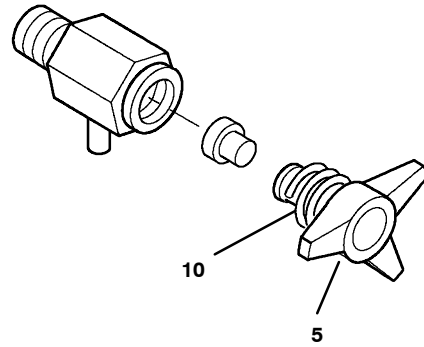
TUCM-16a

TUCM-16b

 Wartungssätze
 Maintenance sets
 Kits de maintenance

Baugruppe 011430 Kondensatablaßhahn
Assembly 011430 Condensate drain tap
Assemblage 011430 Robinet de purge
TUCM-16a

Klasse/ Class/ Classe			Pos.	Bestell-Nr. Part No. No. de cde.	Anz. Qty. Qté.	Benennung	Designation	Dénomination
0	2	5						
			5	068410	1	Ablaßhahnkörper, kpl.	drain valve housing	corps de robinet de purge
X			10	13283-S 01	1	Dichtung	gasket	joint
			15	055888	1	Knebelschraube m. Feder	tommy screw with spring	molette avec ressort

 Wartungssätze
 Maintenance sets
 Kits de maintenance

Baugruppe 055888 Knebelschraube mit Sicherungsfeder
Assembly 055888 Tommy screw with retaining spring
Assemblage 055888 Molette avec ressort
TUCM-16b

Klasse/ Class/ Classe			Pos.	Bestell-Nr. Part No. No. de cde.	Anz. Qty. Qté.	Benennung	Designation	Dénomination
a	b	c						
			5	11392	1	Knebelschraube	tommy screw	molette
			10	13284	1	Sicherungsfeder	locking spring	ressort d'arrêt

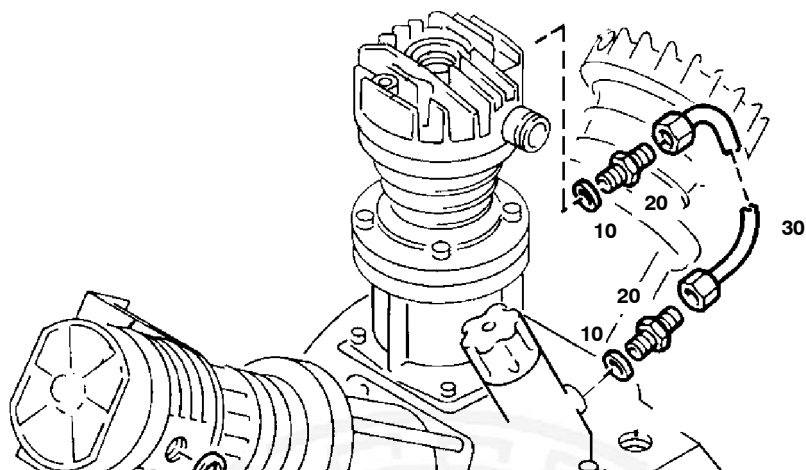
 Wartungssätze
 Maintenance sets
 Kits d'entretien

Baugruppe 81574
Assembly 81574
Assemblage 81574
Zubehör
Accessories
Accessoires
TUCM-17

Klasse/ Class/ Classe			Pos.	Bestell-Nr. Part No. No. de cde.	Anz. Qty. Qté.	Benennung	Designation	Dénomination
a	b	c						
			10	N1316	2	Dichtring	gasket	joint
			20	N20014	2	G-Einschraubstutzen	male connector	raccord droit mâle
			30	73583	1	Verbindungsleitung kpl.	connecting tube assy.	conduite de liaison cpl.

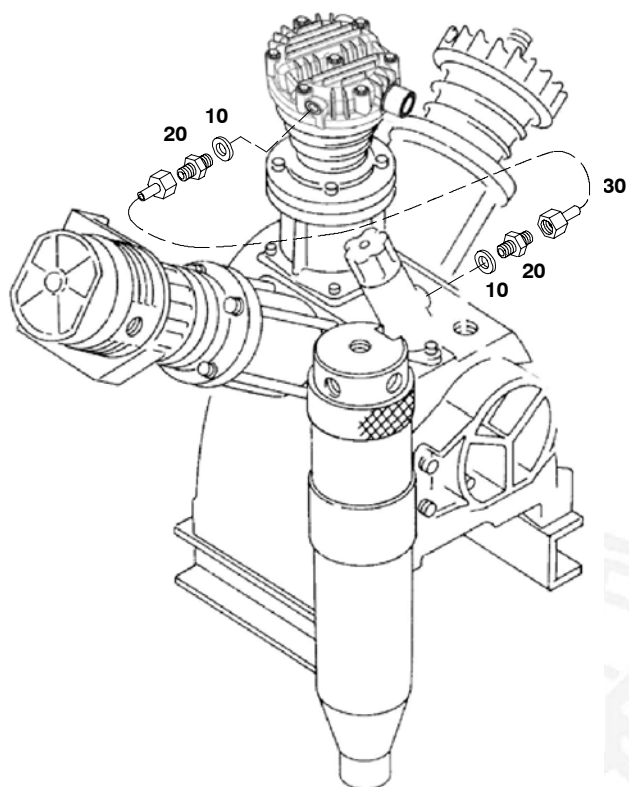
 Wartungssätze
 Maintenance sets
 Kits d'entretien

Baugruppe 81567 **Zubehör**
Assembly 81567 **Accessories**
Assemblage 81567 **Accessoires**
TUCM-18

Klasse/ Class/ Classe			Pos.	Bestell-Nr. Part No. No. de cde.	Anz. Qty. Qté.	Benennung	Designation	Dénomination
a	b	c						
			10	N1316	2	Dichtring	gasket	joint
			20	N20014	2	G-Einschraubstutzen	male connector	raccord droit mâle
			30	81389	1	Verbindungsleitung kpl.	connecting tube assy.	conduite de liaison cpl.

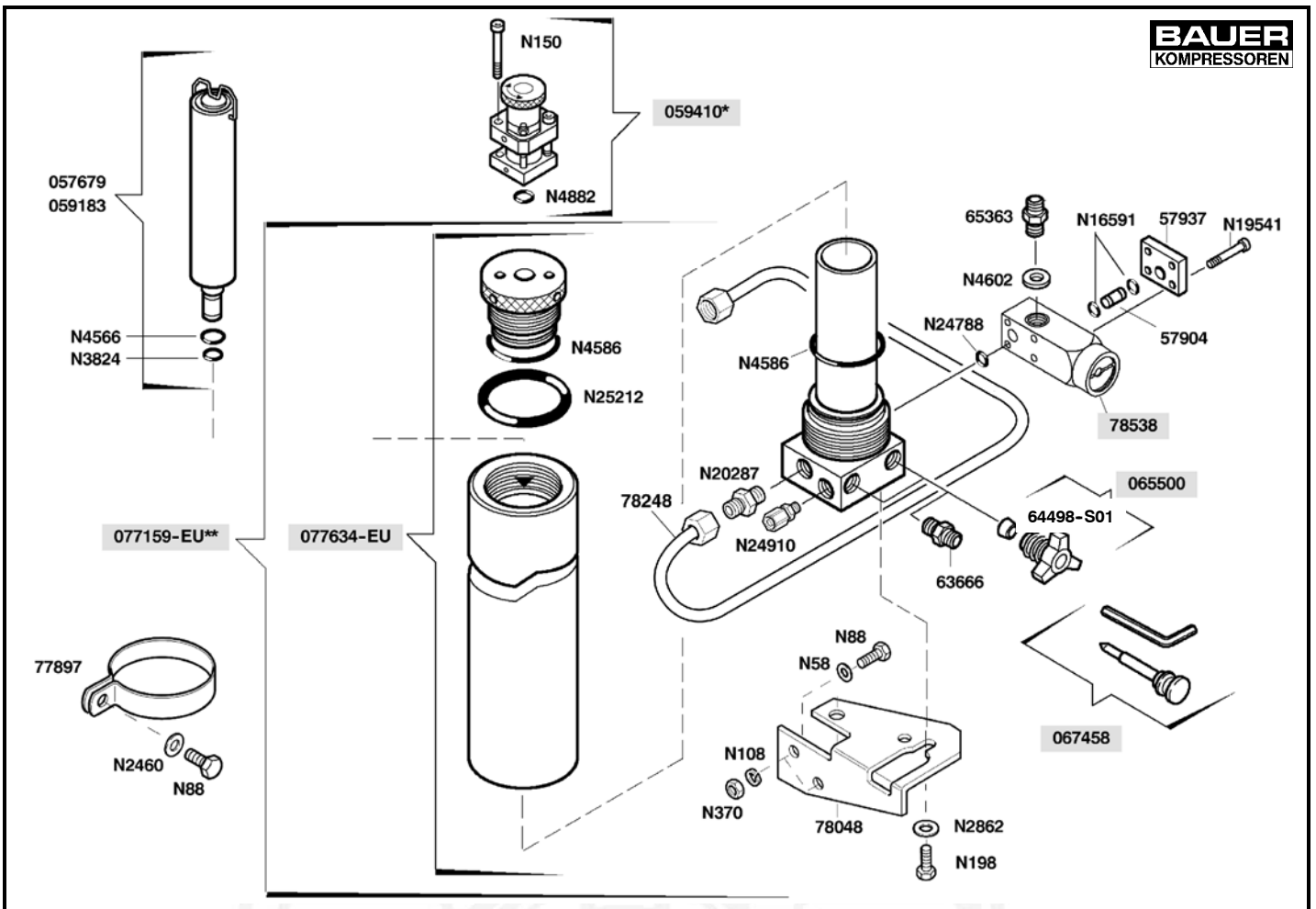

Wartungssätze
Maintenance sets
Kits d'entretien

Bildtafel 78210 **Filtersystem P21**
Figure 78210 **Filter system P21**
Planche 78210 **Système de filtration P21**

TUCM-19

Klasse/ Class/ Classe			Bestell-Nr. Part No. No. de cde.	Benennung	Designation	Dénomination
a	b	c				
			057679	Triplexpatrone	Triplex cartridge	Cartouche Triplex
			059183	Triplexpatrone mit CO-Entf.	Triplex cart. with CO removal	Cart. Triplex avec éli. du CO
			059410*	Sicherheitsventil	Safety valve	Soupape de sûreté
			065500	Kondensatablaßhahn kpl.	Condensate drain tap assy.	Robinet de purge cpl.
			067458	Werkzeugsatz f. Knebelschr.	Tool set for petcock handle	Jeu d'out. pour rob. de purge
			077159-EU**	Filter P21 (ohne Patrone)	Filter P21 (without cartridge)	Syst. P21 (sans cartouche)
			077634-EU	Filtergehäuse kpl.	Filter housing assy	Corps de filtre cpl.
			57904	Verbindungsrohr	Connection pipe	Conduite de connexion
			57937	Abschlußdeckel	Cover	Couvercle
			63666	Gerade Rohrverschraubung	Male connector	Raccord droit mâle
			64498-S01	Dichtung	Gasket	Joint
			65363	UNIMAM-Verschraubung	Connection	Raccord
			77897	Schelle	Clamp	Collier
			78048	Halterung	Bracket	Fixation
			78248	Verbindungsleitung	Connecting line	Tuyau
			78538	Druckhalteventil	Pressure maintaining valve	Clapet de maintien de press.
			N58	Scheibe	Washer	Rondelle
			N88	Sechskantschraube	Hex screw	Vis à six pans
			N108	Federring	Lock washer	Rondelle élastique
			N150	Innensechskantschraube	Allen screw	Vis à six pans creux
			N198	Sechskantschraube	Hex screw	Vis à six pans
			N370	Sechskantmutter	Hex nut	Ecrou hex
			N2460	Scheibe	Washer	Rondelle
			N2862	Scheibe	Washer	Rondelle
			N3824	O-Ring	O-ring	Joint torique
			N4566	O-Ring	O-ring	Joint torique
X			N4586	O-Ring	O-ring	Joint torique

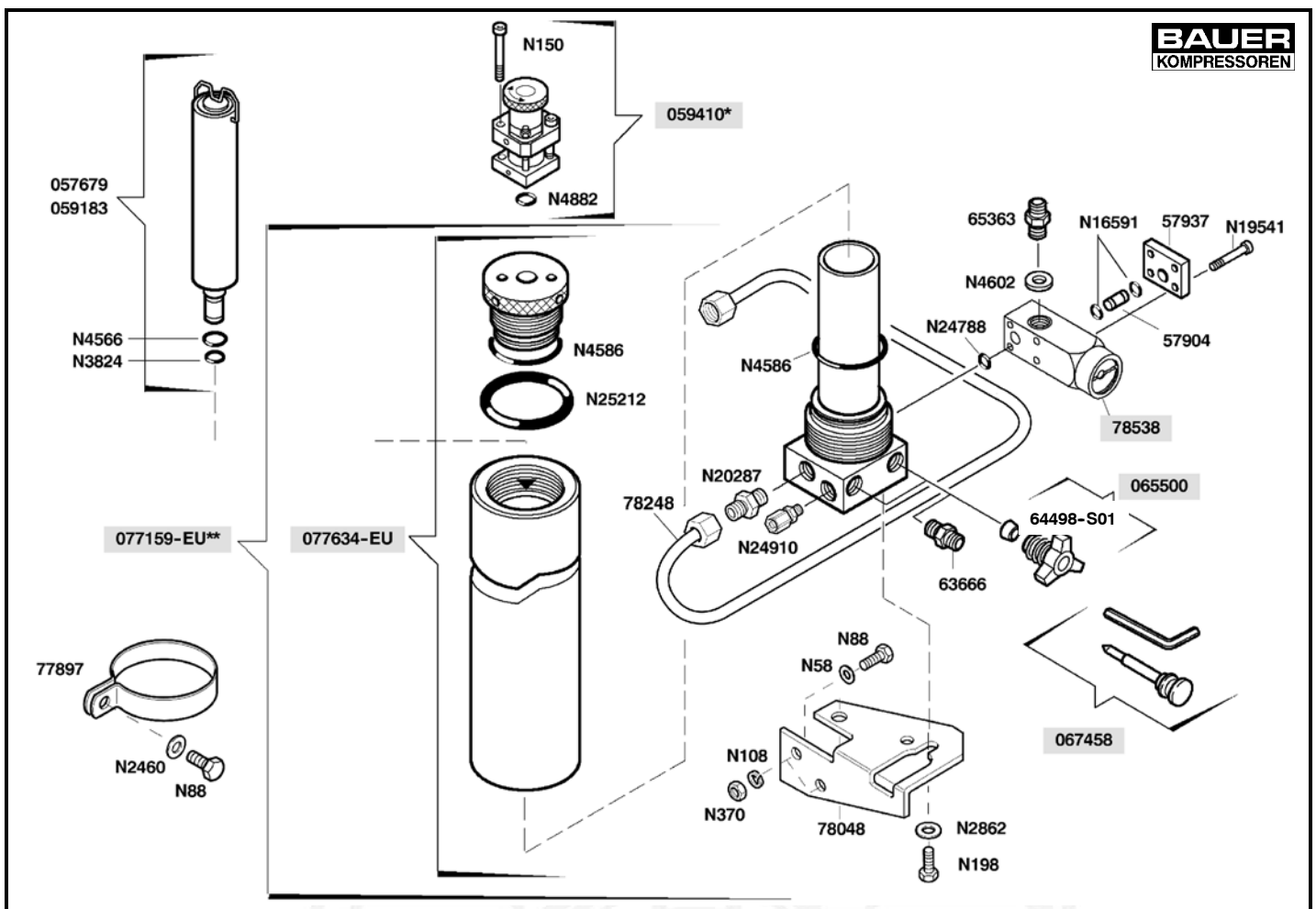
 Wartungssätze
 Maintenance sets
 Kits d'entretien

Bildtafel	78210	Filtersystem P21
Figure	78210	Filter system P21
Planche	78210	Système de filtration P21

TUCM-19

Klasse/ Class/ Classe			Bestell-Nr. Part No. No. de cde.	Benennung	Designation	Dénomination
a	b	c				
	X		N4602	USIT-Ring	USIT-Ring	Joint
			N4882	O-Ring	O ring	Joint torique
			N15500	Gummiprofil	Rubber	Profilé en caoutchouc
			N15550	Schlauchschelle	Clamp	Collier
	X		N16591	O-Ring	O-ring	Joint torique
			N19541	Innensechskantschraube	Allen screw	Vis à six pans creux
			N20287	Gerade Rohrverschraubung	Male connector	Raccord droit mâle
X			N24788	O-Ring	O-ring	Joint torique
			N24910	L-Schnellverschraubung	Male run T connector	Raccord en T renversé
X			N25212	O-Ring	O-ring	Joint torique
			*	Druck bei Bestellung angeben	Indicate pressure on order	Indiquer la pression à la commande
			**	bei Bestellung angeben:/please specify on order:/à spécifier lors de la commande s.v.p.:		
			077159-EU-V001:	Europa; ohne Umschalteneinrichtung / Europe; without switch-over device		
			077159-EU-V002:	Europa; mit Umschalteneinrichtung (siehe TJ-8) / Europe; with switch-over device (see TJ-8)		
				Europa; sans dispositif sélecteur		
				Europa; avec dispositif sélecteur (voir TJ-8)		

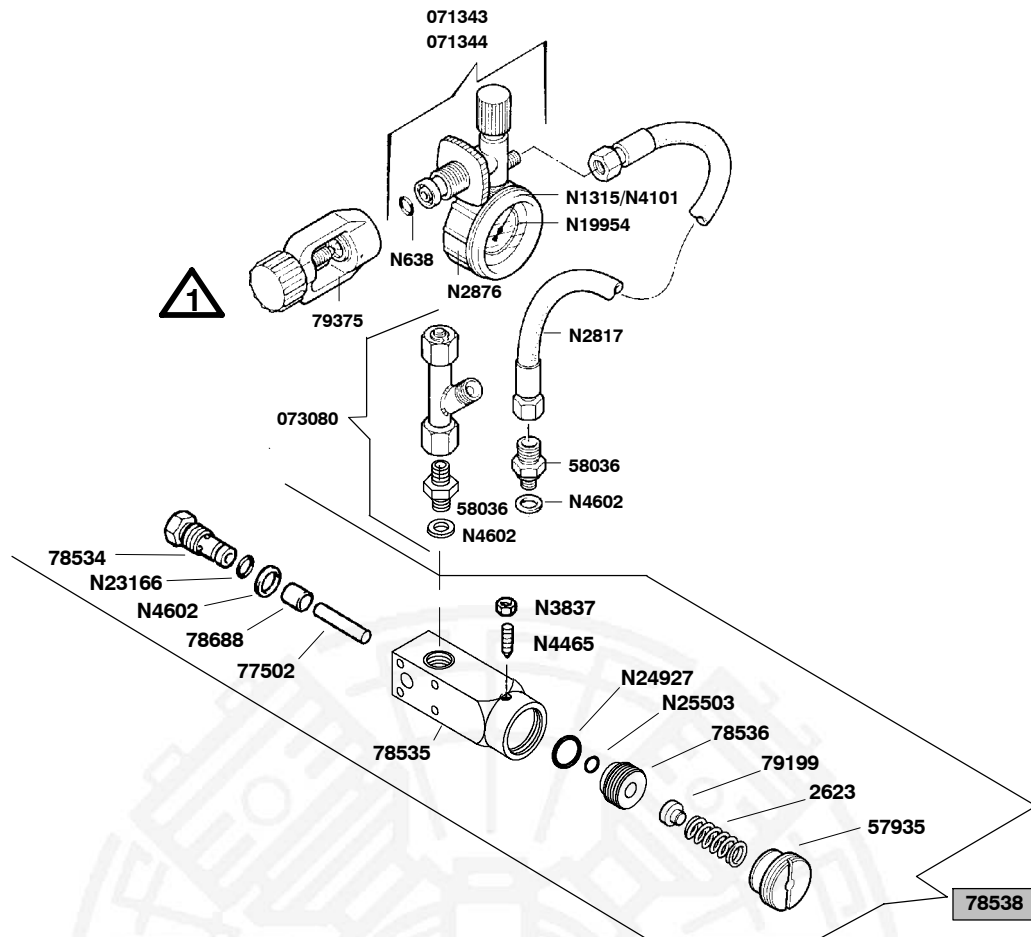
 Wartungssätze
 Maintenance sets
 Kits d'entretien

Bildtafel
Figure
Planche
Druckhalteventil, Fülleinrichtung
Pressure maintaining valve, filling device
Soupape de maintien de pression, dispositif de remplissage
TUCM-20

Klasse/ Class/ Classe			Bestell-Nr. Part No. No. de cde.	Benennung	Designation	Dénomination
a	b	c				
			071343	Füllventil PN200	Filling valve PN200	Robinet de remplissage PN200
			071344	Füllventil PN300	Filling valve PN300	Robinet de remplissage PN300
	X		072349	Reparatursatz für Füllv.	Repair kit for filling valve	Kit de réparation, robinet de remplissage
			073080	Verteiler	Distributor	Distributeur
			2623	Druckfeder	Spring	Ressort
			57935	Einstellschraube	Adjustment screw	Vis de réglage
			58036	Schlauchnippel	Hose nipple	Raccord pour tuyau
			65363	Schlauchnippel	Hose nipple	Raccord pour tuyau
	X		77502	Zylinderstift	Pressure pin	Cheville cylindrique
			78534	Druckhalteventilsitz	Valve seat	Siège du clapet de maintien de pression
			78535	Ventilkörper	Valve housing	Corps de clapet
			78536	Federaufnahme	Spring seat	Siège de ressort
			78538	Druckhalteventil	Pressure maintaining v.	Clapet de maintien de pression
	X		78688	Ventilkolben	Valve piston	Piston de clapet
			79199	Aufnahme	Seat	Siège
			79375	Internat. Füllanschluß	International connection	Raccord international
			N638	O-Ring	O-ring	Joint torique
			N781	Innensechskantschr.	Allen screw	Vis à six pans creux
			N1315	Manometer 0-315 bar	Pressure gauge 0-315 bar	Manomètre 0-315 bar
			N2817	Füllschlauch	Filling hose	Flexible de remplissage
	X		N3837	Sechskantmutter	Hex. nut	Ecrou hexagonal
			N4101	Manometer 0-400 bar	Pressure gauge 0-400 bar	Manomètre 0-400 bar
			N4465	Gewindestift	Stud	Vis sans tête
	X		N4602	USIT-Ring	USIT-Ring	Joint
			N15985	Schutzkappe	Protection cap	Protection
			N19954	Ersatzglas	Replacement glas	Verre de rechange
	X		N23166	O-Ring	O-ring	Joint torique

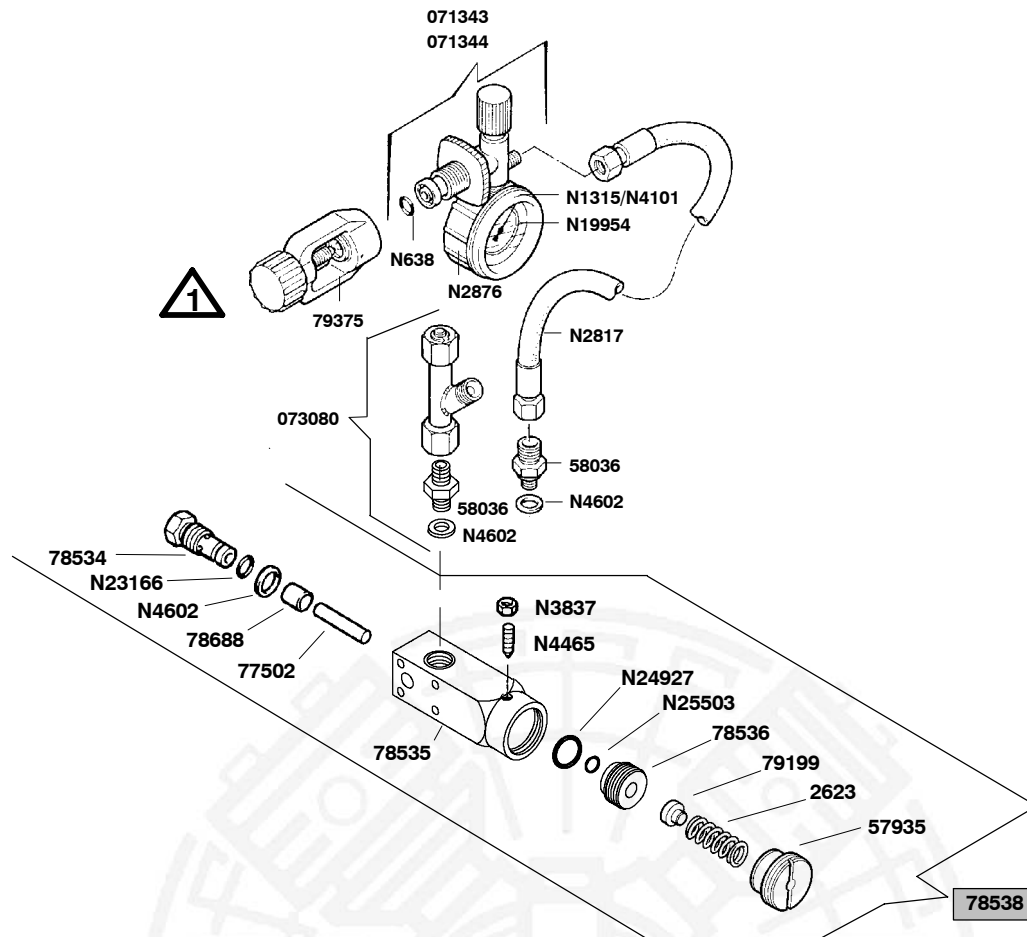

Wartungssätze
Maintenance sets
Kits d'entretien

Bildtafel
Figure
Planche

Druckhalteventil, Fülleinrichtung
Pressure maintaining valve, filling device
Soupape de maintien de pression, dispositif de remplissage

TUCM-20

Klasse/ Class/ Classe			Bestell-Nr. Part No. No. de cde.	Benennung	Designation	Dénomination
a	b	c				
	X		N24927	O-Ring	O-ring	Joint torique
	X		N25503	O-Ring	O-ring	Joint torique

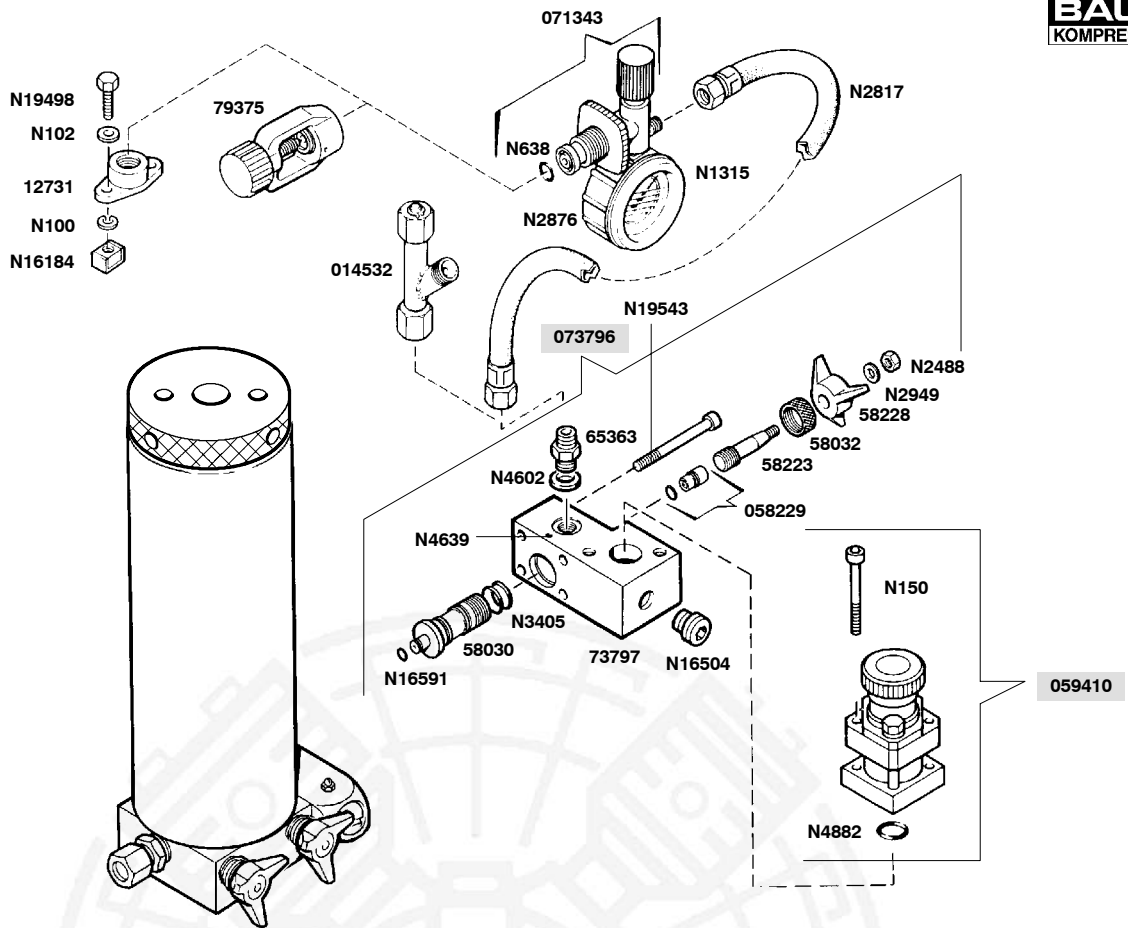
 Wartungssätze
 Maintenance sets
 Kits d'entretien

Bildtafel 073796 Umschalteinrichtung PN200/PN300
Figure 073796 Switch over device PN200/PN300
Planche 073796 Dispositif sélecteur PN200/PN300
TUCM-21

Klasse/ Class/ Classe			Bestell-Nr. Part No. No. de cde.	Benennung	Designation	Dénomination
a	b	c				
			08487	Internat. Füllanschlußbügel	International connection	Raccord international
			014532	Verteiler	Distributor	Distributeur
	X		058229	Spindelkolben kpl.	Spindle piston assy.	Piston de broche cpl.
			059410	Sicherheitsventil	Safety valve	Soupepe de sûreté
			071343	Füllventil	Filling valve	Robinet de remplissage
			073796	Umschalteinrichtung kpl.	Switch over device assy.	Dispositif sélecteur cpl.
			12731	Füllventilbefestigung	Fixation for filling valve	Robinet de remplissage
			58030	Spindelaufnahme	Spindle carrier	Porte broche
			58032	Sicherungsmutter	Lock nut	Contre-écrou
			58223	Spindel	Spindle	Broche
			58228	Knebelgriff	Tap	Manette
			65363	UNIMAM-Verschraubung	Connection	Raccord
			73797	Umschaltleiste	Switch-over block	Bloc sélecteur
			N100	Federring	Lock washer	Rondelle élastique
			N102	Scheibe	Washer	Rondelle
			N150	Innensechskantschraube	Allen screw	Vis à six pans creux
			N638	O-Ring	O-ring	Joint torique
			N1315	Manometer	Pressure gauge	Manomètre
			N2488	Sechskantmutter, selbsts.	Hex. nut, self locking	Ecrou hex., auto-freinant
			N2817	Füllschlauch	Filling hose	Tuyau de remplissage
			N2876	Schutzkappe	Protection cap	Capot de protection
			N2949	Scheibe	Washer	Rondelle
			N3405	O-Ring	O-ring	Joint torique
			N4602	USIT-Ring	USIT-ring	Joint USIT
			N4639	Zylinderkerbstift	Straight grooved pin	Goupille cylindriqur cannellée
			N4882	O-Ring	O ring	Joint torique
			N16184	Käfigmutter	Lock nut	Ecrou frein
			N16504	Verschlußschraube	Cover screw	Vis de fermeture
	X		N16591	O-Ring	O-ring	Joint torique

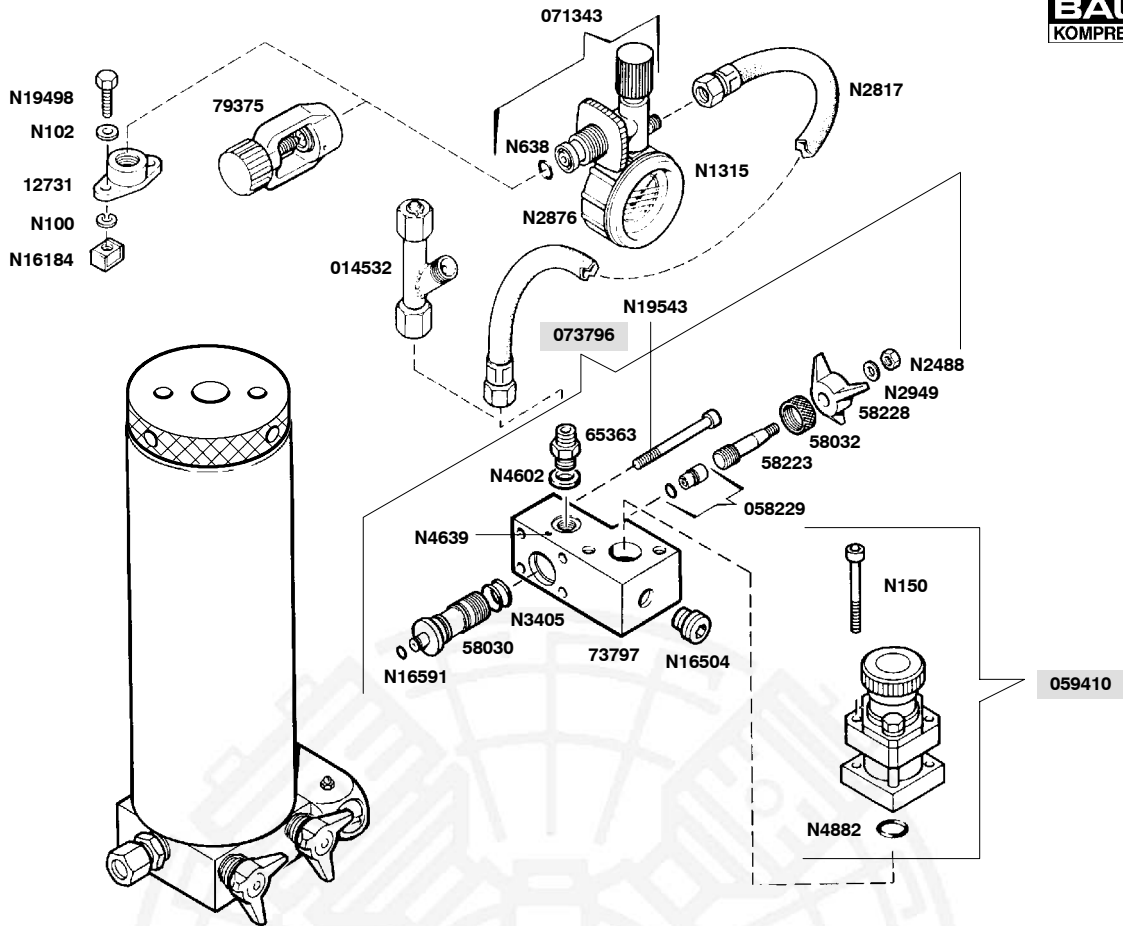

Wartungssätze
 Maintenance sets
 Kits d'entretien

Bildtafel	073796	Umschalteinrichtung PN200/PN300	TUCM-21
Figure	073796	Switch over device PN200/PN300	
Planche	073796	Dispositif sélecteur PN200/PN300	

Klasse/ Class/ Classe			Bestell-Nr. Part No.	Benennung	Designation	Dénomination
a	b	c	No. de cde.			
			N19498	Sechskantschraube	Hex. screw	Vis hexagonale
			N19543	Innensechskantschraube	Allen screw	Vis à six pans creux

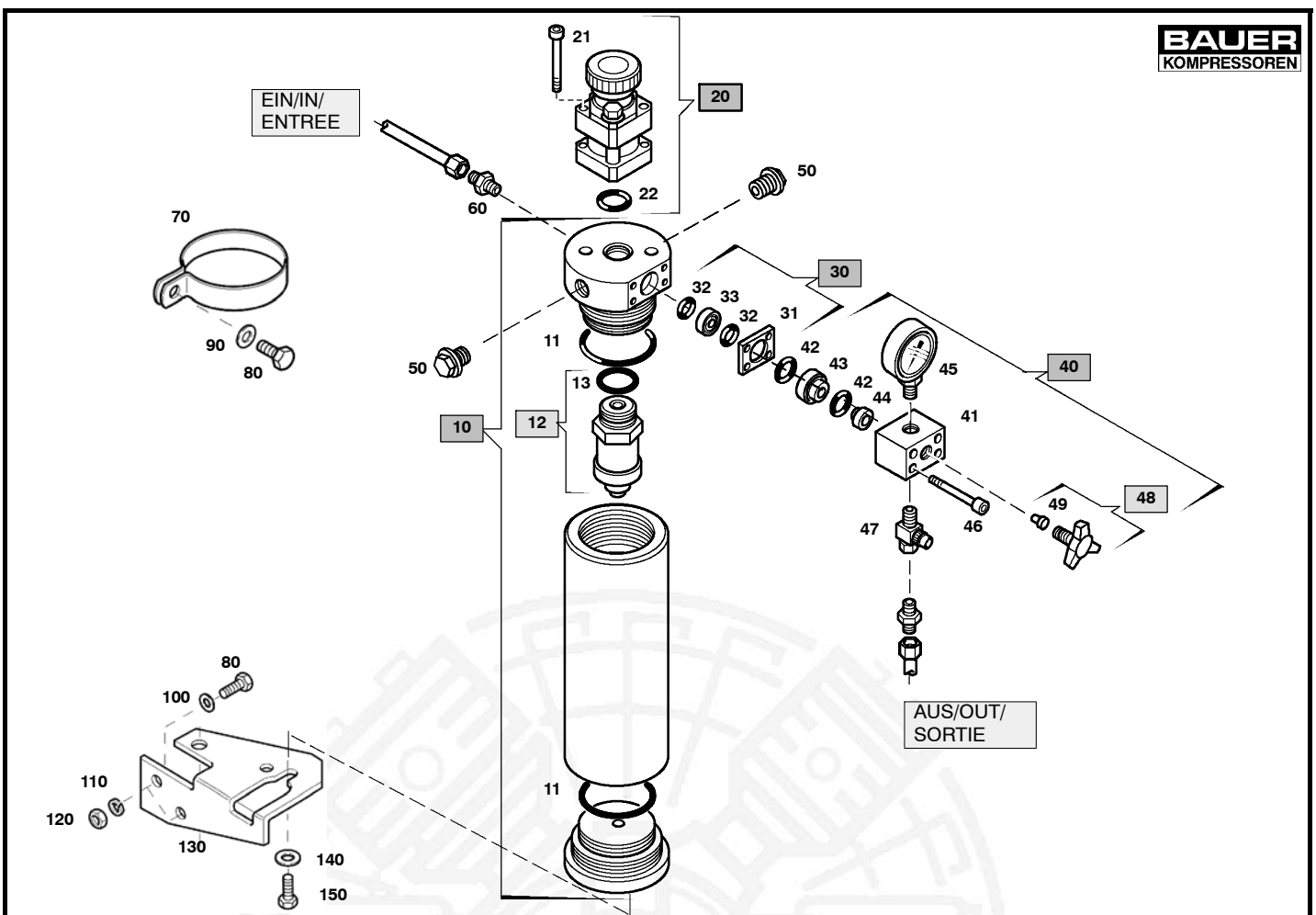
 Wartungssätze
 Maintenance kits
 Kits d'entretien

Baugruppe 090058-EU Endabscheider
Assembly 090058-EU Final separator
Assemblage 090058-EU Séparateur final
TUCM-22

Klasse/ Class/ Classe			Pos.	Bestell-Nr. Part No. No. de cde.	Anz. Qty. Qté.	Benennung	Designation	Dénomination
a	b	c						
			10	090058-EU	1	Endabscheider	final separator	séparateur final
			11	N4586	2	O-Ring	o-ring	joint torique
			12	061860	1	Microfilterpatrone	microfilter cartridge	cartouche microfiltrante
			13	N15133	1	O-Ring	o-ring	joint torique
			20	059410	1	Sicherheitsventil	safety valve	soupape de sûreté
			21	N19555	2	Zylinderschraube	allen screw	vis allen
			22	N4882	1	O-Ring	o-ring	joint torique
			30	071730	1	Adapter kpl.	adapter assy.	adaptateur cpl.
			31	71294	1	Adapter	adapter	adaptateur
			32	N4178	2	O-Ring	o-ring	joint torique
			33	63998	1	Verbindungsniessel	nippel	manchon
			40	071729	1	Rückschlagventil	non-return valve	clapet anti-retour
			41	71295	1	Ventilkörper	valve housing	corps de clapet
			42	N4178	2	O-Ring	o-ring	joint torique
			43	63849	1	Ventilsitz	valve seat	siège de clapet
			44	73767	1	Ventilkolben	valve piston	piston
			45	N16872	1	Manometer	pressure gauge	manomètre
			46	N19543	4	Zylinderschraube	allen screw	vis allen
			47	N16334	1	L-Schnellverschraubung	L-quick coupling	raccord rapide L
			48	065500	1	Knebelschraube	tommy screw	robinet
			49	64498-S01	1	Dichtniessel	nipple	bouchon
			50	N16394	2	Verschlußschraube	plug	bouchon
			60	N20211	1	Gerade Einschraubstutzen	straight male coupling	raccord
			70	77897	1	Rohrschelle	clamp	collier

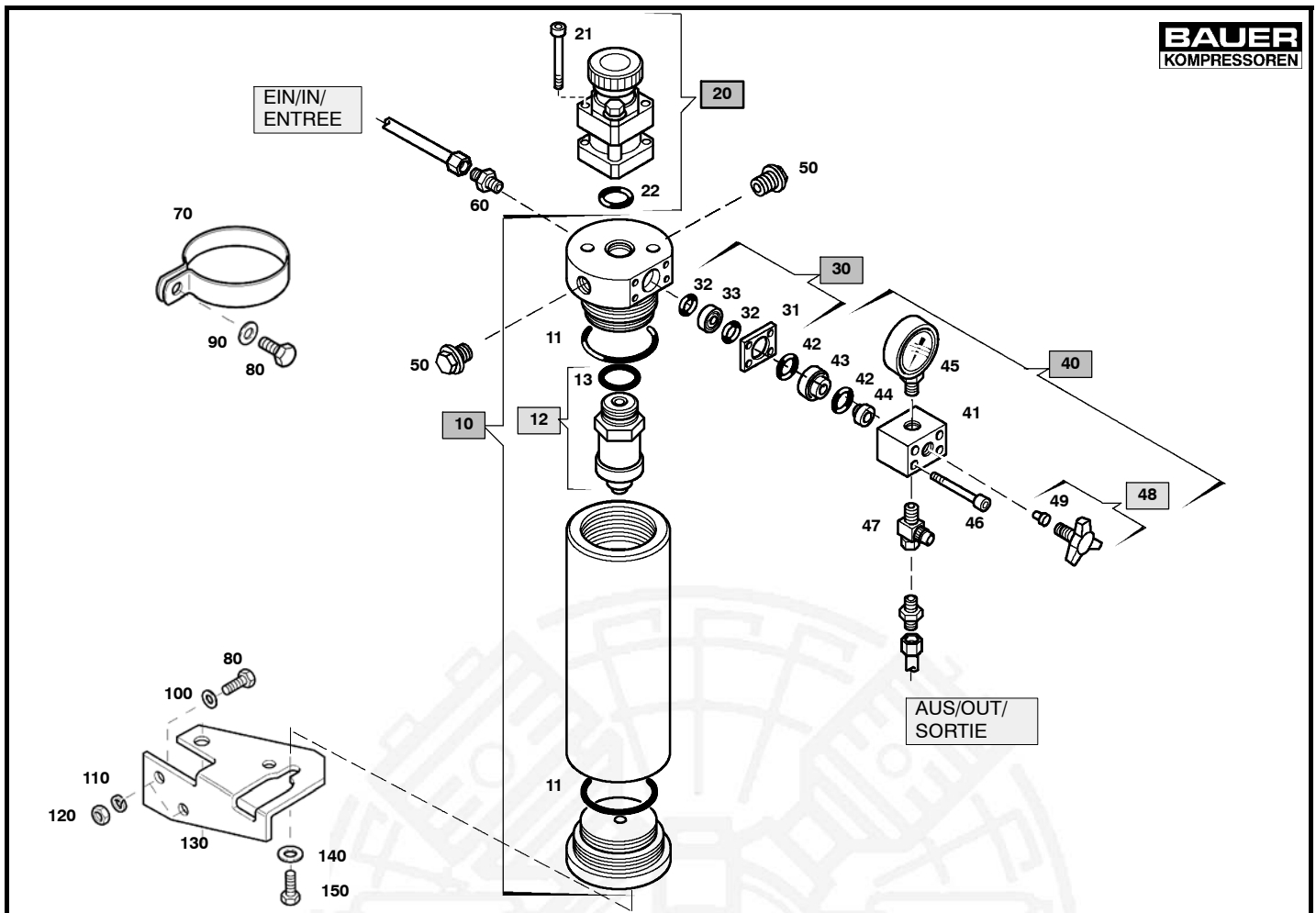

Wartungssätze
Maintenance kits
Kits d'entretien

Baugruppe 090058-EU Endabscheider
 Assembly 090058-EU Final separator
 Assemblage 090058-EU Séparateur final

TUCM-22

Klasse/ Class/ Classe			Pos.	Bestell-Nr. Part No. No. de cde.	Anz. Qty. Qté.	Benennung	Designation	Dénomination
a	b	c						
			80	N88	3	Sechskantschraube	hex. screw	vis à six pans
			90	N2460	1	Scheibe	washer	rondelle
			100	N58	2	Scheibe	washer	rondelle
			110	N108	2	Scheibe	washer	rondelle
			120	N370	2	Mutter	nut	écrou
			130	78048	1	Winkel	support	fixation
			140	N2862	2	Scheibe	washer	rondelle
			150	N198	2	Sechskantschraube	hex. screw	vis à six pans

Standard

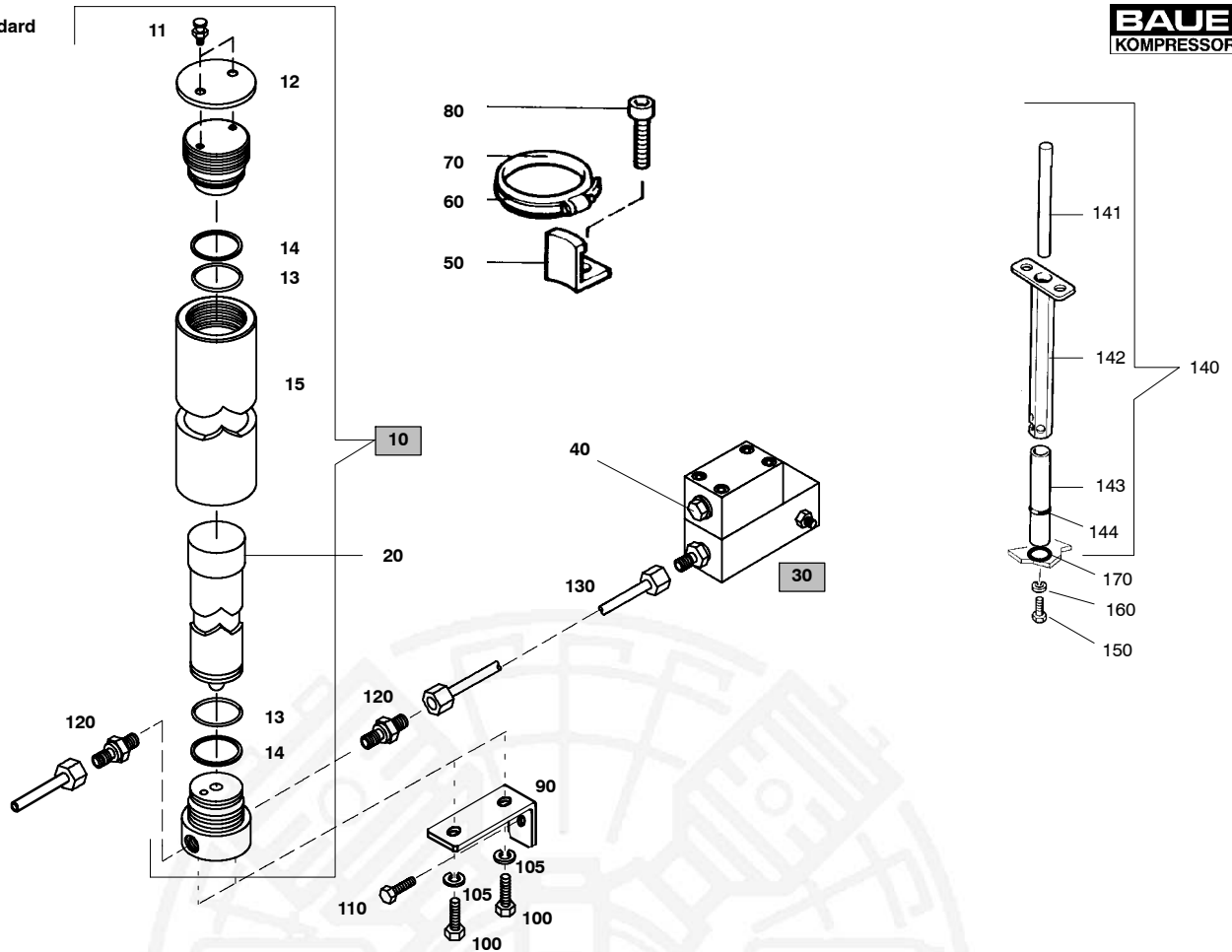
BAUER
KOMPRESSORENWartungssätze
Maintenance kits
Kits d'entretien**Baugruppe Filtersystem P41 BKM standard/TÜV**
Assembly Filter system P41 BKM standard/TÜV
Assemblage Système de filtration P41 BKM standard/TÜV**TUCM-22a**

Klasse/ Class/ Classe			Pos.	Bestell-Nr. Part No. No. de cde.	Anz. Qty. Qté.	Benennung	Designation	Dénomination
a	b	c						
			10	062042-EU	1	Filterbehälter	filter housing	corps de filtre
			11	12293	2	Befestigungsschraube	fastening screw	vis de fixation
			12	61237	1	Schutzdeckel	protecting cover	couvercle protecteur
			13	N4736	2	Stützring	backup ring	bague d'appui
			14	N4735	2	O-Ring	op-ring	joint torique
			20	067224	1	Filterpatrone f. H ₂ O, Öl und CO	filter cartridge f. H ₂ O, oil and CO	cartouche filtrante p. H ₂ O, huile et CO
				062565	1	Filterpatrone f. H ₂ O und Öl	filter cartridge f. H ₂ O and oil	cartouche filtrante p. H ₂ O et huile
			30	80751	1	Druckhalte- Rückschlagventil	Maintaining/non-return valve	soupape de maintien de p./ anti-retour
			40	N16309	1	Verschlußstopfen	plug	bouchon
			50	61646	1	Winkel	support	équerre de fixation
			60	N15499	1	Schlauchschelle	clamp	collier
			70	N15500	1	Gummiprofil	rubber band	bande de caoutchouc
			80	N19495	1	Schraube	screw	vis
			90	79560	1	Winkel	support	équerre
			100	N19511	2	Schraube	screw	vis
			105	N176	2	Federring	spring washer	rondelle fendue
			110	N19495	1	Schraube	screw	vis
			120	N20404	2	Gerade-Einschraubstutzen	straight male coupling	raccord
			130	N3619	2m	Rohr	tube	tuyau
			140	075226	1	Filterschlüssel	filter key	clef de filtre
			141	66691	1	Stange	pin	tige
			142	66690	1	Schlüssel	key	clef
			143	65694	1	Halterung	support	support

Standard

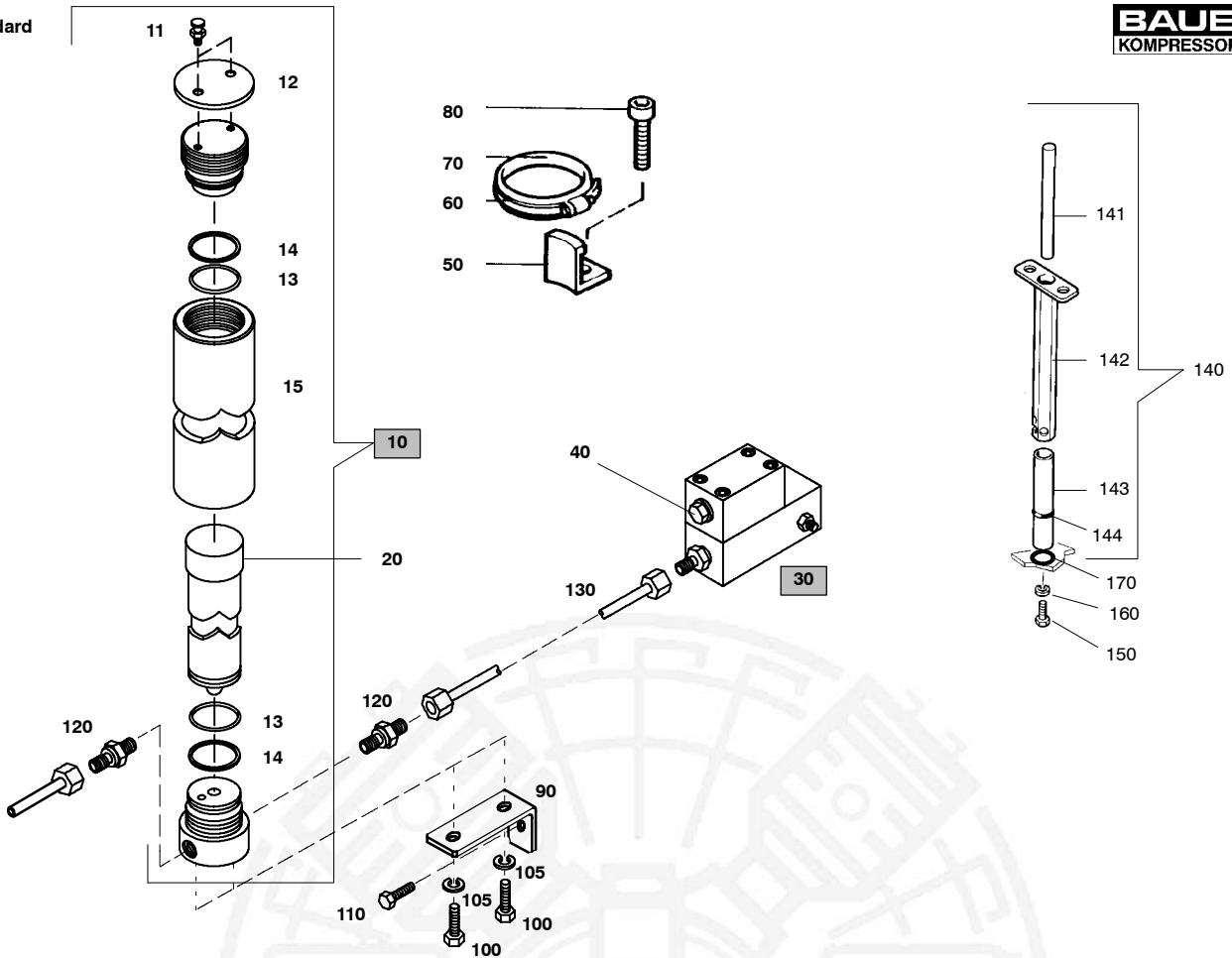

Wartungssätze
Maintenance kits
Kits d'entretien

Baugruppe Filtersystem P41 BKM standard/TÜV
Assembly Filter system P41 BKM standard/TÜV
Assemblage Système de filtration P41 BKM standard/TÜV

TUCM-22a

Klasse/ Class/ Classe			Pos.	Bestell-Nr. Part No. No. de cde.	Anz. Qty. Qté.	Benennung	Designation	Dénomination
a	b	c						
			144	N2806	1	O-Ring	o-ring	joint torique
			150	N19495	1	Schraube	screw	vis
			160	N100	1	Federring	spring washer	rondelle fendue
			170	N3521	1	O-Ring	o-ring	joint torique

SECURUS

BAUER
KOMPRESSOREN

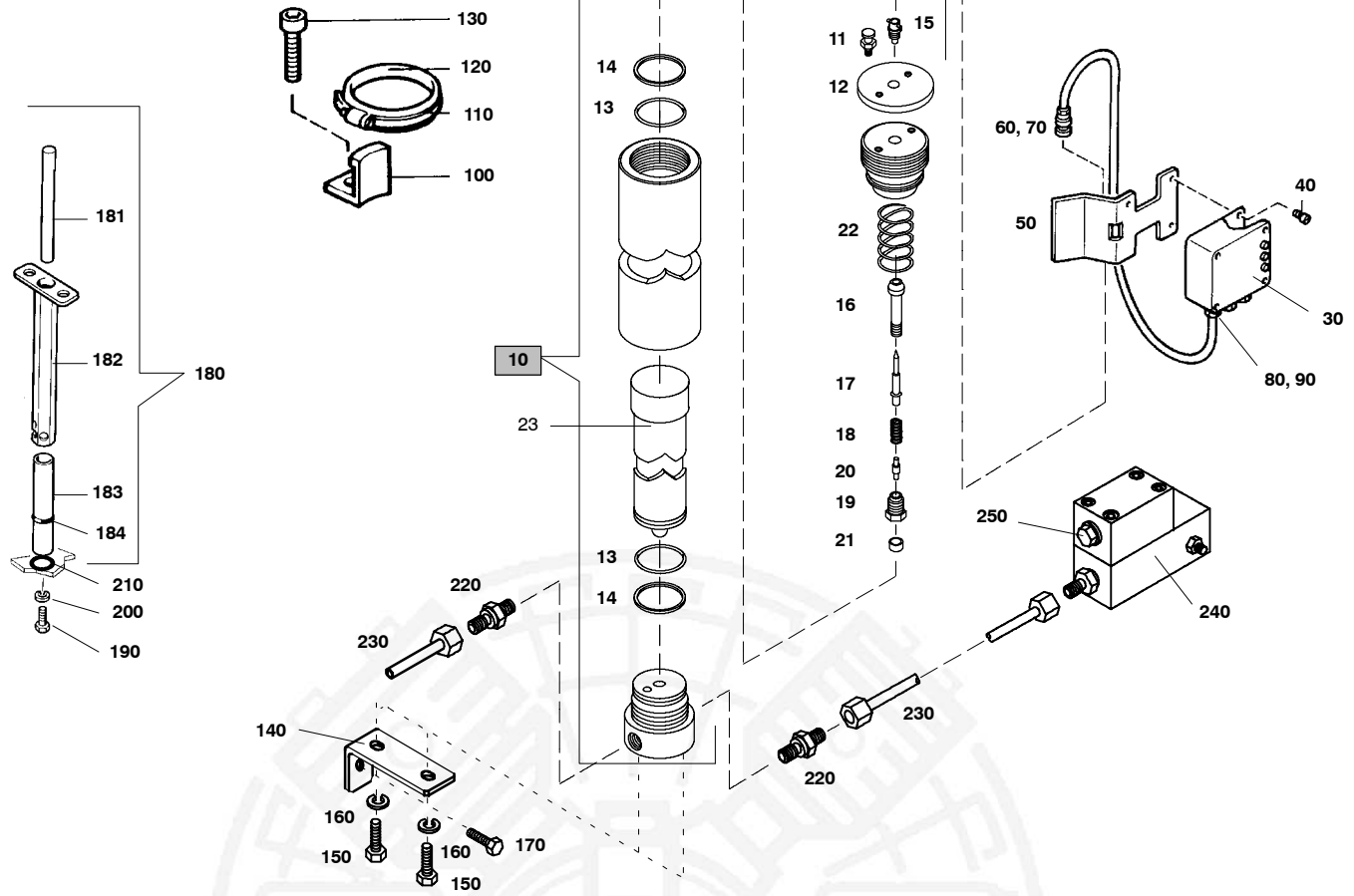

Wartungssätze
Maintenance kits
Kits d'entretien

Baugruppe Filtersystem P41 mit Securus
Assembly Filter system P41 with Securus
Assemblage Système de filtration avec Securus

TUCM-22b

Klasse/ Class/ Classe			Pos.	Bestell-Nr. Part No. No. de cde.	Anz. Qty. Qté.	Benennung	Designation	Dénomination
a	b	c						
			10	061685-EU	1	Filterbehälter	filter housing	corps de filtre
			11	12293	2	Befestigungsschraube	fastening screw	vis de fixation
			12	60135	1	Schutzdeckel	protecting cover	couvercle protecteur
			13	N4736	2	Stützring	backup ring	bague d'appui
			14	N4735	2	O-Ring	op-ring	joint torique
			15	59850	1	Buchse BNC	Socket BNC	Connecteur BNC
			16	59851	1	Bolzen	Bolt	Boulon
			17	59853	1	Stift	Pin	Goupille
			18	60062	1	Feder	Spring	Ressort
			19	59852	1	Schraube	Screw	Vis
			20	59854	1	Stift	Pin	Goupille
			21	59855	1	Mutter	Nut	Écrou
			22	2181	1	Druckfeder	Pressure spring	Ressort
			23	061686	1	Filterpatrone f. H ₂ O, Öl	filter cartridge f. H ₂ O, oil	cartouche filtrante pour H ₂ O, huile
				061687	1	Filterpatrone f. H ₂ O, Öl und CO	filter cartridge f. H ₂ O, oil and CO	cartouche filtrante pour H ₂ O, huile et CO
			30	N18362	1	Securus-Meldegerät	Securus control box	boîtier de contrôle Securus
			40	N4345	4	Schraube	screw	vis
			50	65759	1	Halterung	support	fixation
			60	N19987	1	Stecker	coupling	connecteur
			70	N19988	1	Abdeckung	cover	protection
			80	N3101	1	Kabelverschraubung	cable coupling	raccord
			90	N3104	1	Gegenmutter	counter nut	contre-écrou
			100	61646	1	Winkel	support	équerre de fixation
			110	N15499	1	Schlauchschelle	clamp	collier

SECURUS

BAUER
KOMPRESSOREN

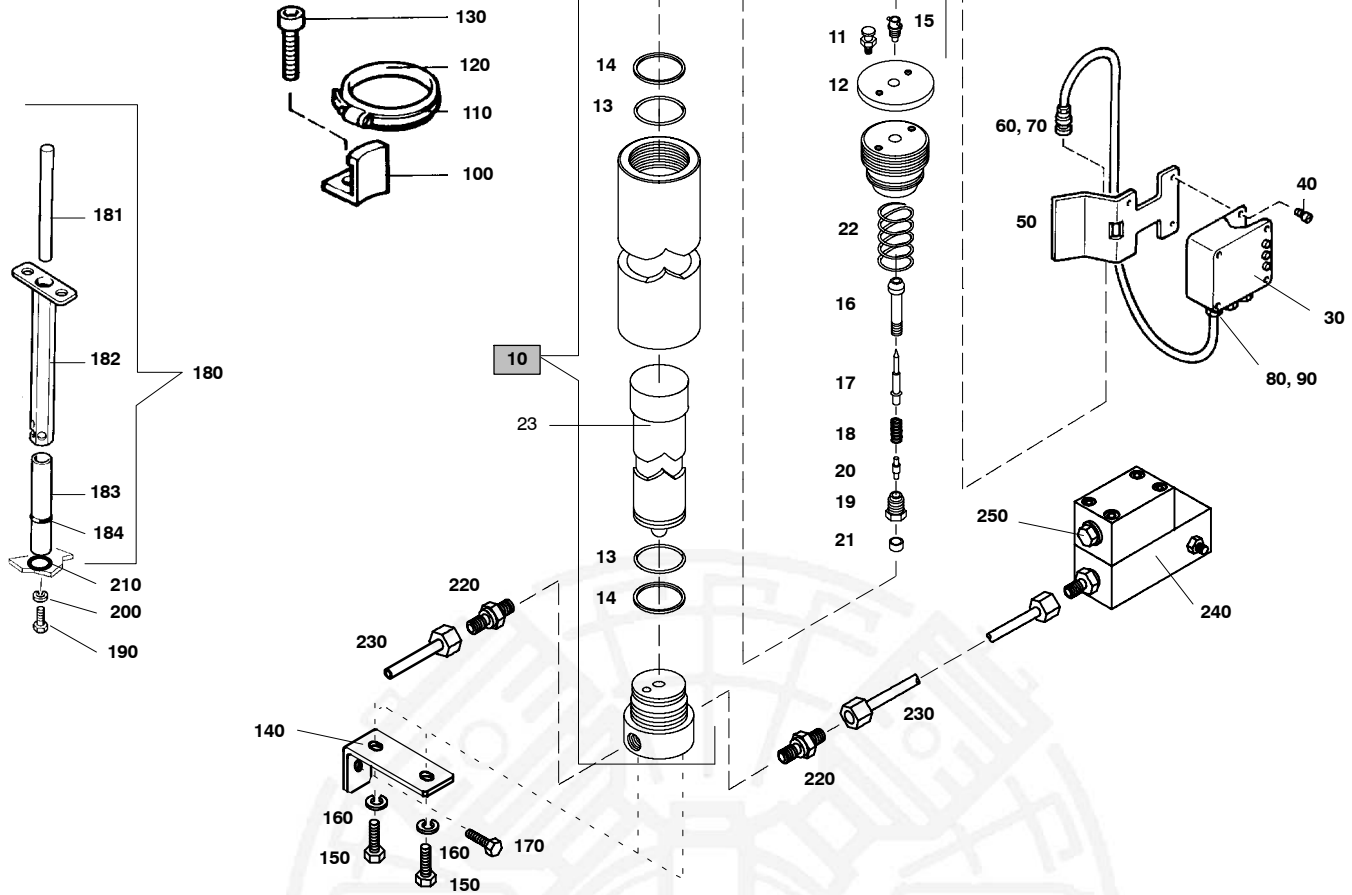

Wartungsätze
Maintenance kits
Kits d'entretien

Baugruppe Filtersystem P41 mit Securus
Assembly Filter system P41 with Securus
Assemblage Système de filtration avec Securus

TUCM-22b

Klasse/ Class/ Classe			Pos.	Bestell-Nr. Part No. No. de cde.	Anz. Qty. Qté.	Benennung	Designation	Dénomination
a	b	c						
			120	N15500	1	Gummiprofil	rubber band	bande de caoutchouc
			130	N19495	1	Schraube	screw	vis
			140	79560	1	Winkel	support	équerre
			150	N19511	2	Schraube	screw	vis
			160	N176	2	Federring	spring washer	rondelle fendue
			170	N19495	1	Schraube	screw	vis
			180	075226	1	Filterschlüssel	filter key	clef de filtre
			181	66691	1	Stange	pin	tige
			182	66690	1	Schlüssel	key	clef
			183	65694	1	Halterung	support	support
			184	N2806	1	O-Ring	o-ring	joint torique
			190	N19495	1	Schraube	screw	vis
			200	N100	1	Federring	spring washer	rondelle fendue
			210	N3521	1	O-Ring	o-ring	joint torique
			220	N20404	2	Gerade-Einschraubstutzen	straight male coupling	raccord
			230	N3619	2m	Rohr	tube	tuyau
			240	80751	1	Druckhalte- Rückschlagventil	Maintaining/non-return valve	soupape de maintien de p./ anti-retour
			250	N16309	1	Verschlußstopfen	plug	bouchon

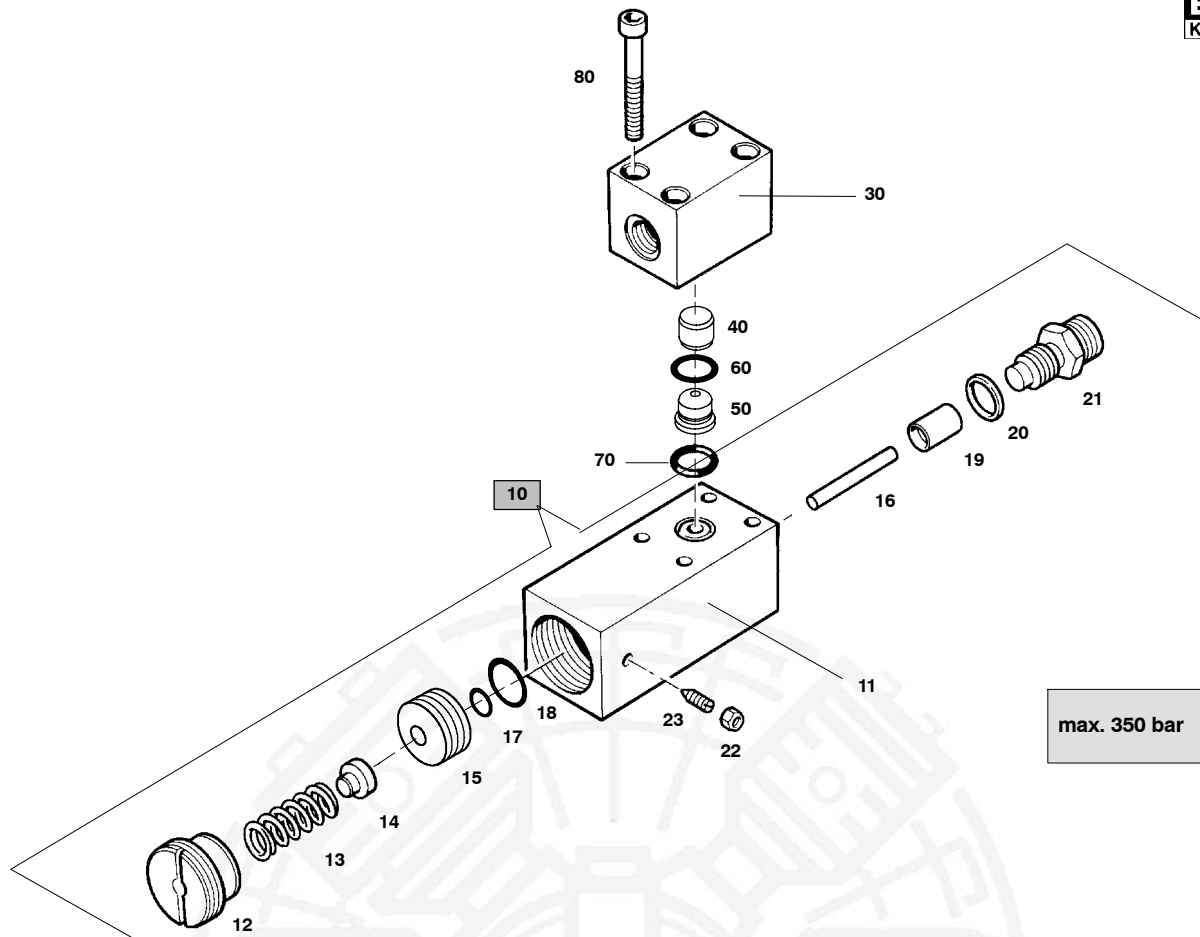

max. 350 bar

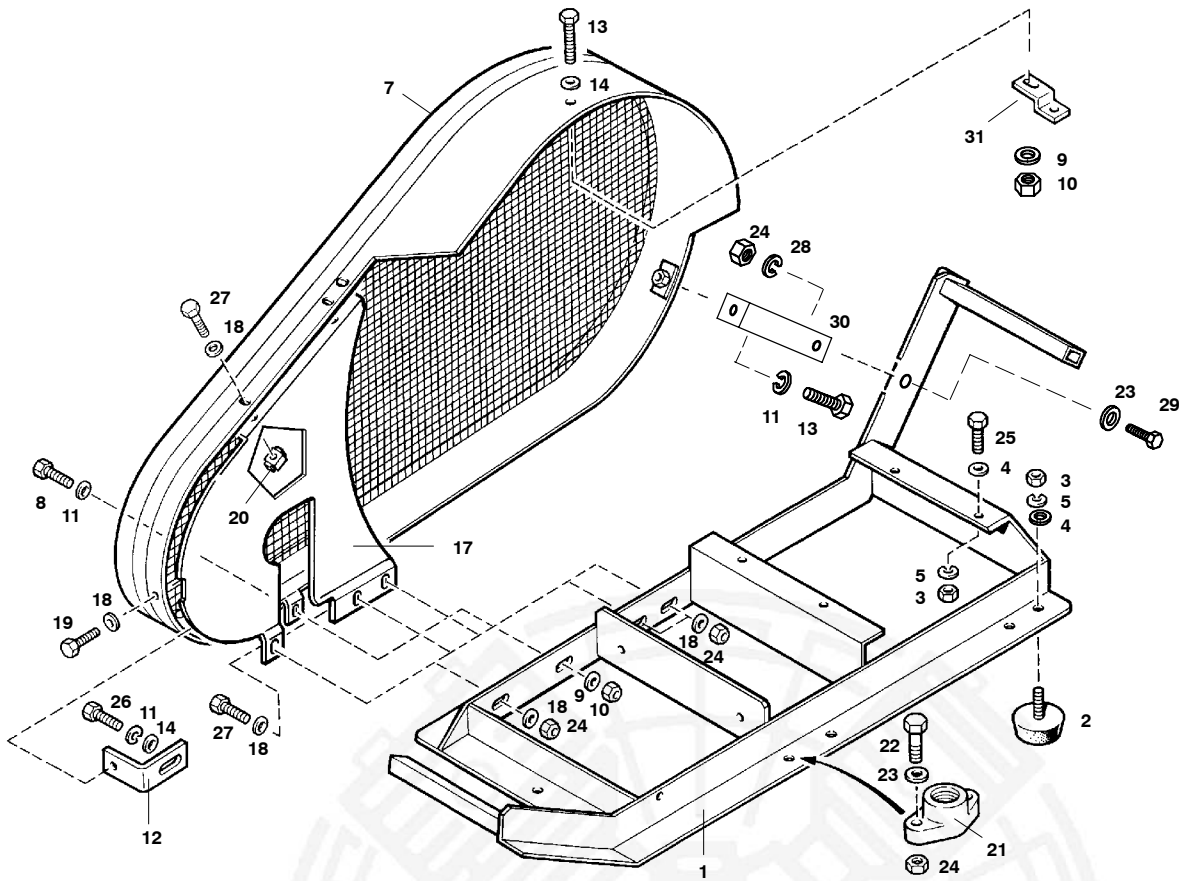

Wartungssätze
Maintenance kits
Kits d'entretien
Baugruppe 80751
Assembly 80751
Assemblage 80751
Druckhalteventil
Pressure maintaining valve
Soupape de maintien de pression
TUCM-22c

Klasse/ Class/ Classe			Pos.	Bestell-Nr. Part No. No. de cde.	Anz. Qty. Qté.	Benennung	Designation	Dénomination
a	b	c						
			10	80719	1	Druckhalteventil	pressure maintaining valve	Soupape de maintien de pression
			11	80720	1	Ventilkörper	valve housing	corps de soupape
			12	57935	1	Einstellschraube	adjusting screw	vis de réglage
			13	2623	1	Druckfeder	pressure spring	ressort
			14	57762	1	Aufnahme f. Feder	spring seat	siège de ressort
			15	78536	1	Aufnahme	seat	siège
			16	77245	1	Zylinderstift	bolt	goupille
			17	N25503	1	O-Ring	o-ring	joint torique
			18	N24927	1	O-Ring	o-ring	joint torique
			19	78688	1	Ventilkolben	valve piston	piston
			20	N4602	1	USIT-Ring	usit-ring	joint usit
			21	63841	1	Ventilsitz	valve seat	siège de soupape
			22	N3837	1	Sechskantmutter	hex nut	écrou hex.
			23	N4465	1	Gewindestift	set screw	goujon fileté
			30	80746	1	Ventilkörper	valve housing	corps de soupape
			40	73767	1	Ventilkolben	valve piston	piston
			50	80716	1	Ventilsitz	valve seat	siège de soupape
			60	N24927	1	O-Ring	o-ring	joint torique
			70	N3824	1	O-Ring	o-ring	joint torique
			80	N19539	4	Zylinderschraube	allen screw	vis allen

 Wartungssätze
 Maintenance sets
 Kits d'entretien

Bildtafel 78842 **Tragrahmen Utilus II, Capitano II**
Figure 78842 **Portable frame Utilus II, Capitano II**
Planche 78842 **Cadre portable Utilus II, Capitano II**
TUCM-23

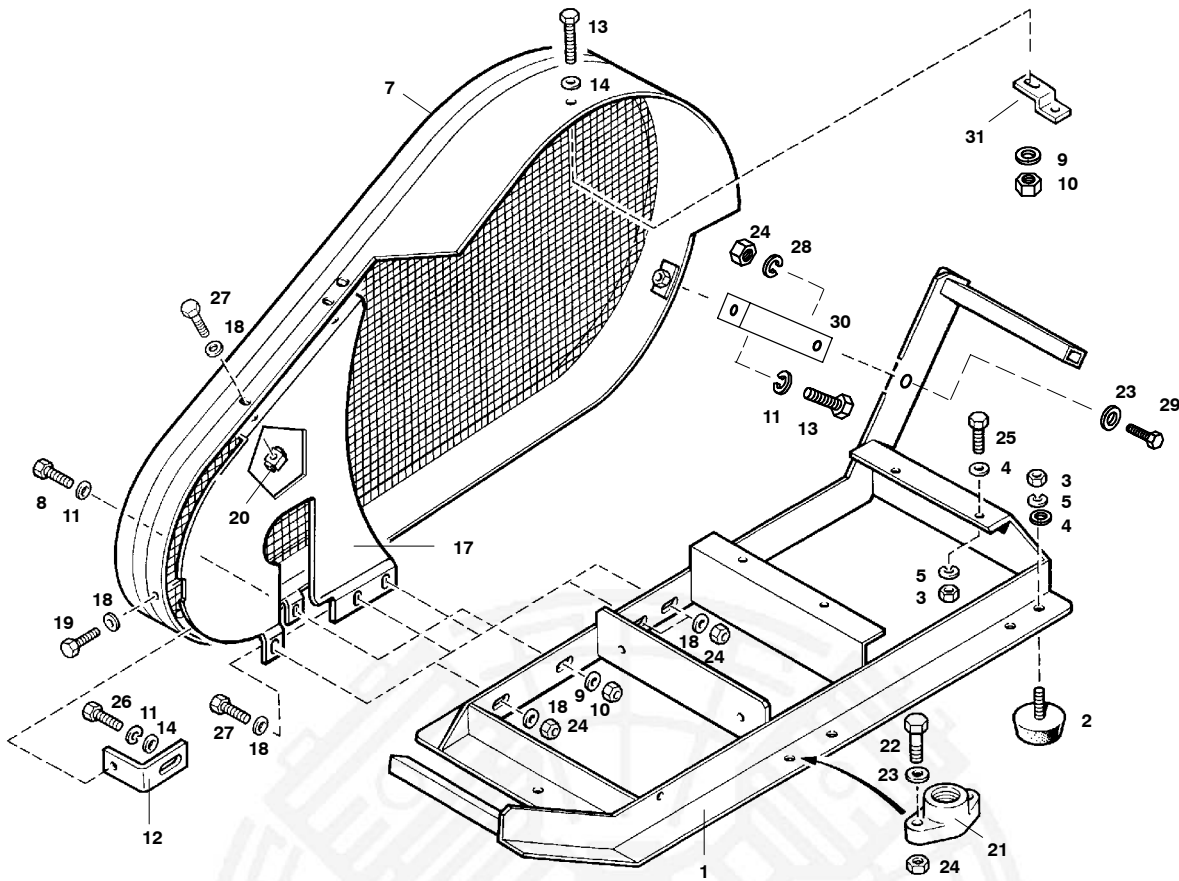
Klasse/ Class/ Classe			Pos.	Bestell-Nr. Part No. No. de cde.	Benennung	Designation	Dénomination
a	b	c					
			1	78753	Tragrahmen	Frame	Cadre
			2	N1547	Schwingmetall	Vibration isolator	Amortisseur
			3	N177	Sechskantmutter	Hex. nut	Ecrou hexagonal
			4	N16	Scheibe	Washer	Rondelle
			5	N176	Federring	Lock washer	Rondelle élastique
			6		entfällt	deleted	annulé
			7	78768	Riemenschutz	Belt guard	Protection de courroie
			8	N19506	Sechskantschraube	Hex. screw	Vis hexagonale
			9	N58	Scheibe	Washer	Rondelle
			10	N370	Sechskantmutter	Hex. nut	Ecrou hexagonal
			11	N108	Federring	Lock washer	Rondelle élastique
			12	67587	Anschlagwinkel	Angle for petrol engine	Equerre pour moteur à gaz
			13	N19505	Sechskantschraube	Hex. screw	Vis hexagonale
			14	N2460	Scheibe	Washer	Rondelle
			15	N19547	Zylinderschraube	Allen screw	Vis à six pans creux
			16	N57	Sechskantmutter	Hex. nut	Ecrou hexagonal
			17	79224	Abdeckplatte	Cover plate	Plaque de recouvrement
			18	N3313	Scheibe	Washer	Rondelle
			19	N19496	Sechskantschraube	Hex. screw	Vis hexagonale
			20	N16184	Käfigmutter	Lock nut	Ecrou frein
			21	12731	Füllventilbefestigung	Filling valve bracket	Fixation robinet de rempliss.
			22	N19499	Sechskantschraube	Hex. screw	Vis hexagonale
			23	N102	Scheibe	Washer	Rondelle
			24	N1042	Sechskantmutter	Hex. nut	Ecrou hexagonal
			25	N19512	Sechskantschraube	Hex. screw	Vis hexagonale
			26	N15122	Sechskantschraube	Hex. screw	Vis hexagonale
			27	N19495	Sechskantschraube	Hex. screw	Vis hexagonale
			28	N100	Federring	Lock washer	Rondelle élastique
			29	N19495	Sechskantschraube	Hex. screw	Vis hexagonale



Wartungssätze
Maintenance sets
Kits d'entretien

Bildtafel 78842
Figure 78842
Planche 78842

Tragrahmen Utilus II, Capitano II
Portable frame Utilus II, Capitano II
Cadre portable Utilus II, Capitano II

TUCM-23

Klasse/ Class/ Classe			Pos.	Bestell-Nr. Part No. No. de cde.	Benennung	Designation	Dénomination
a	b	c					
			30	79221	Anschlagwinkel	Angle	Equerre de butée
			31	59032	Befestigungslasche	Bracket	Fixation

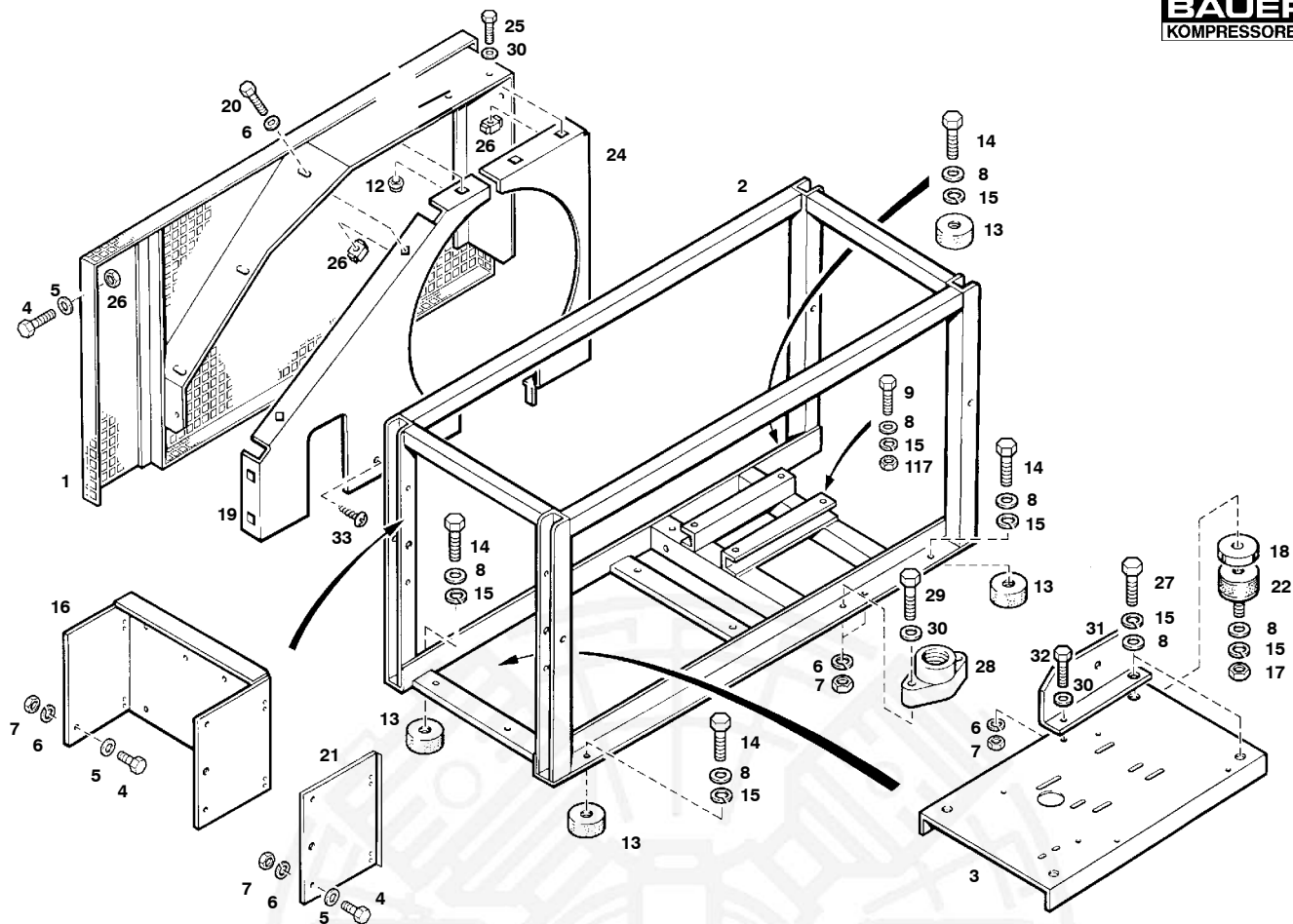



 Wartungssätze
 Maintenance sets
 Kits d'entretien

Bildtafel 78843 **Sturzrahmen, Utilus II**
Figure 78843 **Protection Frame, Utilus II**
Planche 78843 **Cadre de protection, Utilus II**

TUCM-24

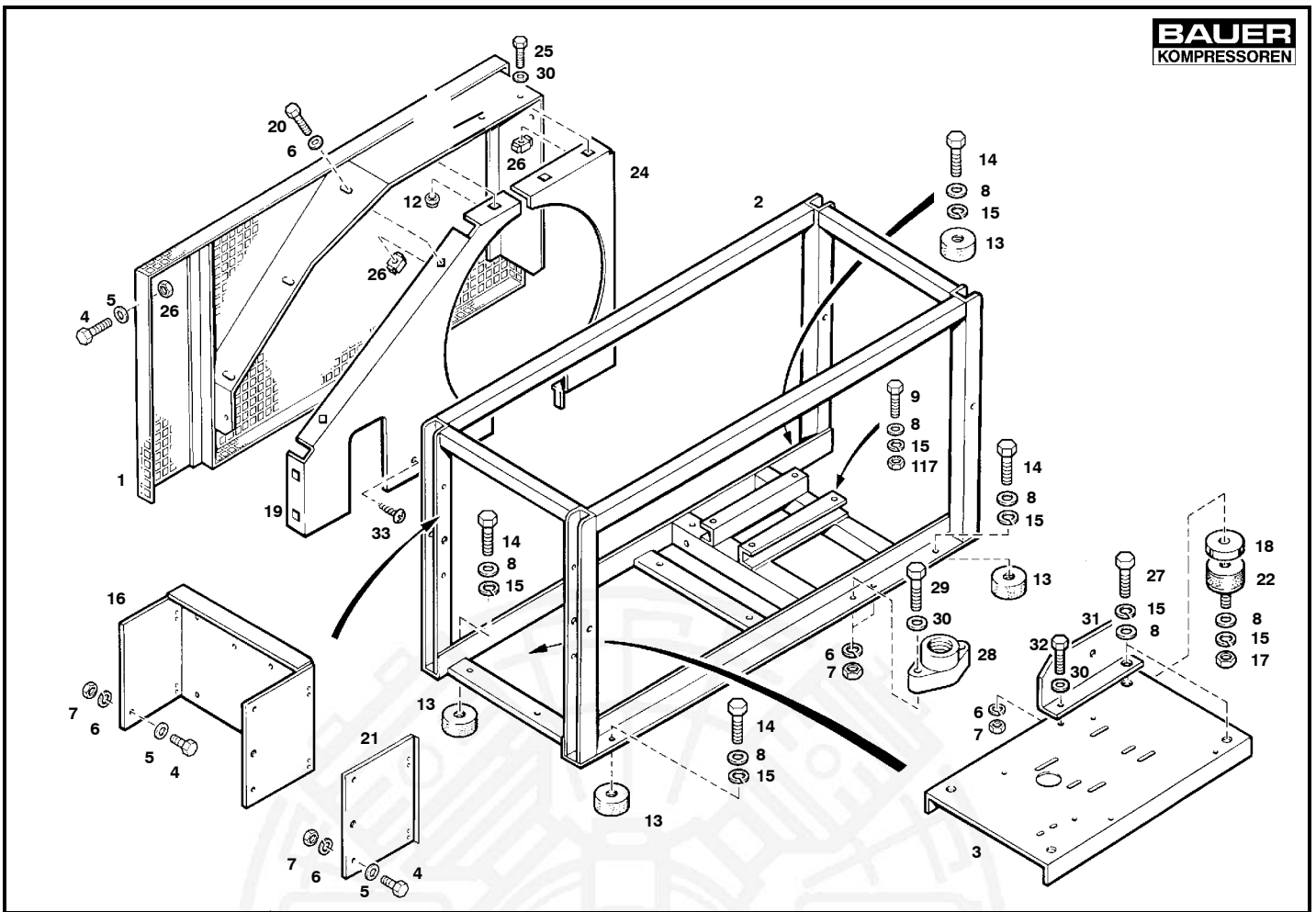
Klasse/ Class/ Classe			Pos.	Bestell-Nr. Part No. No. de cde.	Benennung	Designation	Dénomination
a	b	c					
			1	81455	Riemenschutz	Belt guard	Protection de courroie
			2	78751	Sturzrahmen	Frame	Cadre
			3	71602	Schwingrahmen	Frame	Cadre
			4	N19495	Sechskantschraube	Hex. screw	Vis hexagonale
			5	N102	Scheibe	Washer	Rondelle
			6	N100	Federring	Lock washer	Rondelle élastique
			7	N287	Sechskantmutter	Hex. nut	Ecrou hexagonal
			8	N16	Scheibe	Washer	Rondelle
			9	N19512	Sechskantschraube	Hex. screw	Vis hexagonale
			10	N58	Scheibe	Washer	Rondelle
			11	N108	Federring	Lock washer	Rondelle élastique
			12	N57	Sechskantmutter	Hex. nut	Ecrou hexagonal
			13	N3290	Schwingmetall	Vibration isolator	Amortisseur
			14	N570	Sechskantschraube	Hex. screw	Vis hexagonale
			15	N176	Federring	Washer	Rondelle
			16	78767	Montageblech	Mounting plate	Tôle de fixation
			17	N177	Sechskantmutter	Hex. nut	Ecrou hexagonal
			18	60858	Scheibe	Washer	Rondelle
			19	75581	Schutzblech	Guard plate	Tôle de protection
			20	N19494	Sechskantschraube	Hex. screw	Vis hexagonale
			21	73173	Montageblech	Mounting plate	Tôle de fixation
			22	N1649	Schwingmetall	Vibration isolator	Amortisseur
			23	N3638	Sechskantschraube	Hex. screw	Vis hexagonale
			24	78752	Schutzblech	Guard plate	Tôle de protection
			25	N2139	Sechskantschraube	Hex. screw	Vis hexagonale
			26	N26455	Schwing-Mutter	Nut	Ecrou
			27	N3957	Sechskantschraube	Hex. screw	Vis hexagonale
			28	12731	Füllventilbefestigung	Bracket for filling valve	Fixation pour robinet de rempl.
			29	N19499	Sechskantschraube	Hex. screw	Vis hexagonale
			30	N102	Scheibe	Washer	Rondelle



Wartungssätze
Maintenance sets
Kits d'entretien

Bildtafel 78843
Figure 78843
Planche 78843

Sturzrahmen, Utilus II
Protection Frame, Utilus II
Cadre de protection, Utilus II

TUCM-24

Klasse/ Class/ Classe			Pos.	Bestell-Nr. Part No. No. de cde.	Benennung	Designation	Dénomination
a	b	c					
			31	72163	Schutzblech	Guard plate	Tôle de protection
			32	N19495	Sechskantschraube	Hex. screw	Vis hexagonale
			33	N20667	Sechskantschraube	Hex. screw	Vis hexagonale

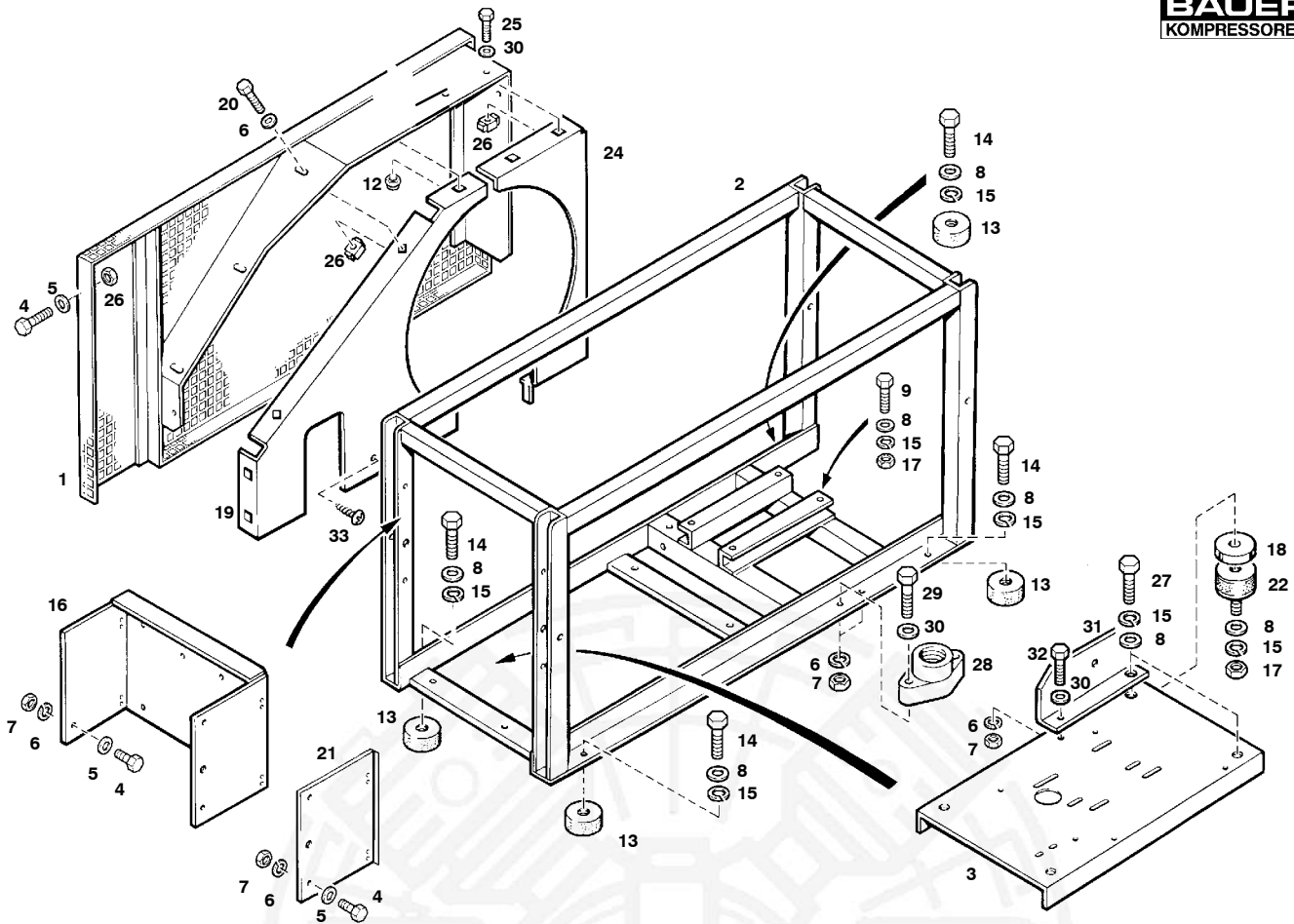
 Wartungssätze
 Maintenance sets
 Kits d'entretien

Bildtafel 78892 **Sturzrahmen, Capitano II**
Figure 78892 **Protection frame, Capitano II**
Planche 78892 **Cadre de protection, Capitano II**
TUCM-25

Klasse/ Class/ Classe			Pos.	Bestell-Nr. Part No. No. de cde.	Benennung	Designation	Dénomination
a	b	c					
			1	81455	Riemenschutz	Belt guard	Protection de courroie
			2	78751	Sturzrahmen	Frame	Cadre
			3	71601	Schwingrahmen	Frame	Cadre
			4	N19495	Sechskantschraube	Hex. screw	Vis hexagonale
			5	N102	Scheibe	Washer	Rondelle
			6	N100	Federring	Lock washer	Rondelle élastique
			7	N287	Sechskantmutter	Hex. nut	Ecrou hexagonal
			8	N16	Scheibe	Washer	Rondelle
			9	N19512	Sechskantschraube	Hex. screw	Vis hexagonale
			10	N58	Scheibe	Washer	Rondelle
			11	N108	Federring	Lock washer	Rondelle élastique
			12	N57	Sechskantmutter	Hex. nut	Ecrou hexagonal
			13	N3290	Schwingmetall	Vibration isolator	Amortisseur
			14	N570	Sechskantschraube	Hex. screw	Vis hexagonale
			15	N176	Federring	Washer	Rondelle
			16	78767	Montageblech	Mounting plate	Tôle de fixation
			17	N177	Sechskantmutter	Hex. nut	Ecrou hexagonal
			18	60858	Scheibe	Washer	Rondelle
			19	75581	Schutzblech	Guard plate	Tôle de protection
			20	N19494	Sechskantschraube	Hex. screw	Vis hexagonale
			21	73173	Montageblech	Mounting plate	Tôle de fixation
			22	N1649	Schwingmetall	Vibration isolator	Amortisseur
			23	N3638	Sechskantschraube	Hex. screw	Vis hexagonale
			24	78752	Schutzblech	Guard plate	Tôle de protection
			25	N2139	Sechskantschraube	Hex. screw	Vis hexagonale
			26	N26455	Schwing-Mutter	Nut	Ecrou
			27	N3957	Sechskantschraube	Hex. screw	Vis hexagonale
			28	12731	Füllventilbefestigung	Bracket for filling valve	Fixation pour robinet de rempl.
			29	N19499	Sechskantschraube	Hex. screw	Vis hexagonale
			30	N102	Scheibe	Washer	Rondelle

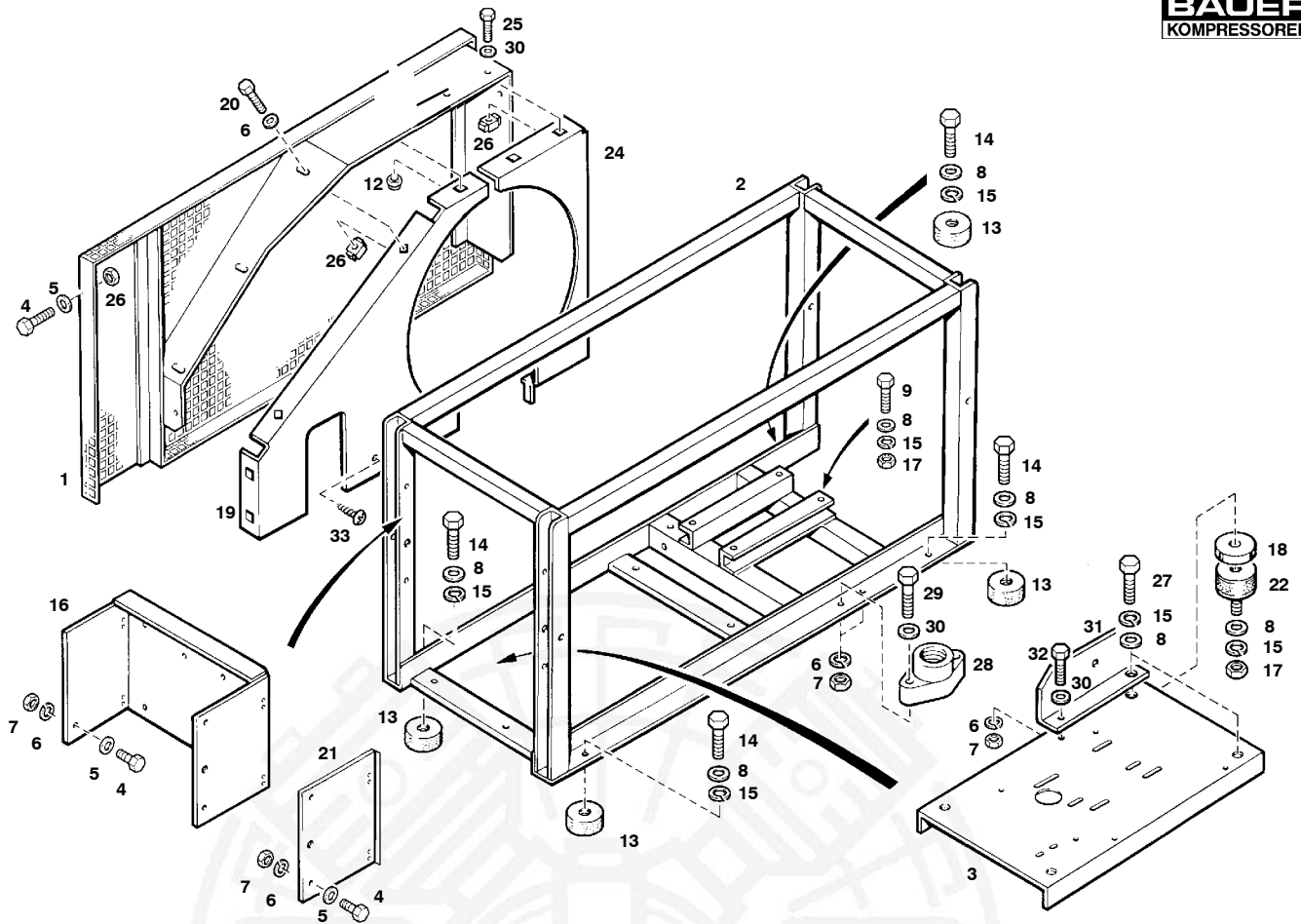

Wartungssätze
 Maintenance sets
 Kits d'entretien

Bildtafel 78892
Figure 78892
Planche 78892

Sturzrahmen, Capitano II
Protection frame, Capitano II
Cadre de protection, Capitano II

TUCM-25

Klasse/ Class/ Classe			Pos.	Bestell-Nr. Part No. No. de cde.	Benennung	Designation	Dénomination
a	b	c					
			31	72163	Schutzblech	Guard plate	Tôle de protection
			32	N19495	Sechskantschraube	Hex. screw	Vis hexagonale
			33	N20667	Sechskantschraube	Hex. screw	Vis hexagonale

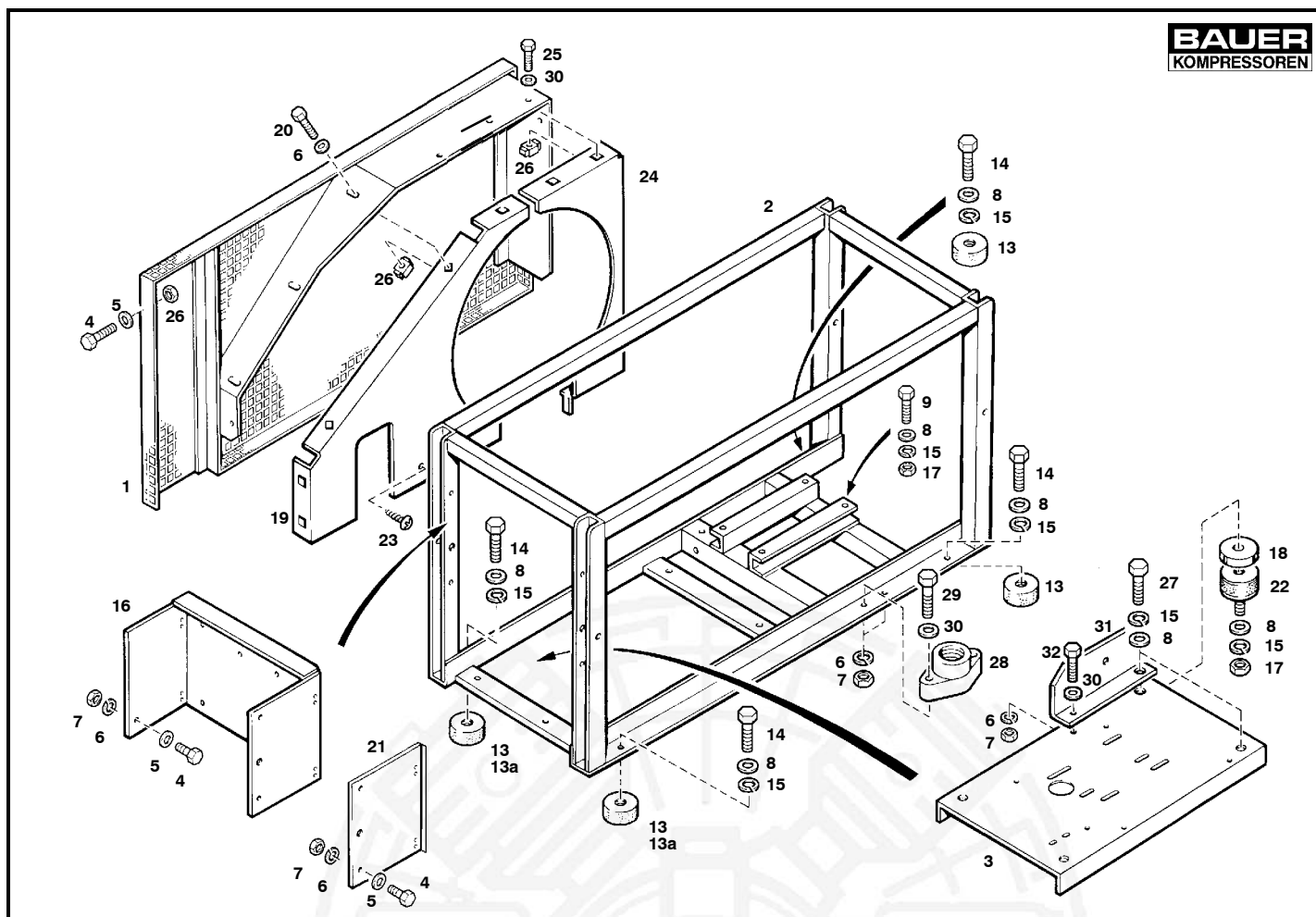



 Wartungssätze
 Maintenance sets
 Kits d'entretien

Bildtafel 78891 **Sturzrahmen, Mariner II**
Figure 78891 **Protection frame, Mariner II**
Planche 78891 **Cadre de protection, Mariner II**

TUCM-26

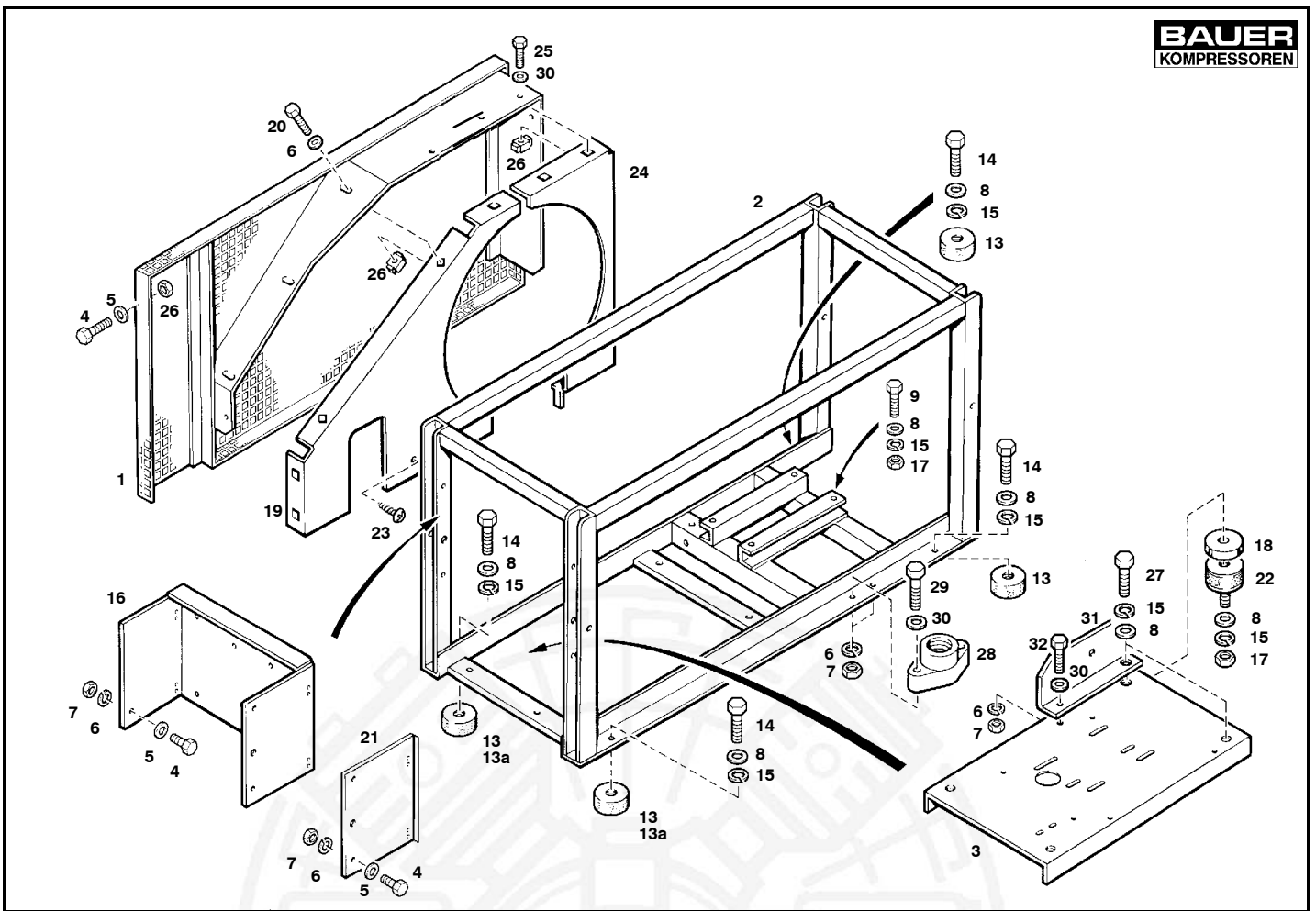
Klasse/ Class/ Classe			Pos.	Bestell-Nr. Part No. No. de cde.	Benennung	Designation	Dénomination
a	b	c					
			1	81455	Riemenschutz	Belt guard	Protection de courroie
			2	78751	Sturzrahmen	Frame	Cadre
			3	70622	Schwingrahmen	Frame	Cadre
			4	N19495	Sechskantschraube	Hex. screw	Vis hexagonale
			5	N102	Scheibe	Washer	Rondelle
			6	N100	Federring	Lock washer	Rondelle élastique
			7	N287	Sechskantmutter	Hex. nut	Ecrou hexagonal
			8	N16	Scheibe	Washer	Rondelle
			9	N19512	Sechskantschraube	Hex. screw	Vis hexagonale
			10	N58	Scheibe	Washer	Rondelle
			11	N108	Federring	Lock washer	Rondelle élastique
			12	N57	Sechskantmutter	Hex. nut	Ecrou hexagonal
			13	N3290	Schwingmetall	Vibration isolator	Amortisseur
			13a	N3292	Schwingmetall (Benzinmotor)	Vibration isolator (petrol eng.)	Amortisseur (moteur à ess.)
			14	N570	Sechskantschraube	Hex. screw	Vis hexagonale
			15	N176	Federring	Washer	Rondelle
			16	78767	Montageblech	Mounting plate	Tôle de fixation
			17	N177	Sechskantmutter	Hex. nut	Ecrou hexagonal
			18	60858	Scheibe	Washer	Rondelle
			19	75581	Schutzblech	Guard plate	Tôle de protection
			20	N19494	Sechskantschraube	Hex. screw	Vis hexagonale
			21	73173	Montageblech	Mounting plate	Tôle de fixation
			22	N1649	Schwingmetall	Vibration isolator	Amortisseur
			23	N20667	Blechschaube	Sheet metal screw	Vis à tôle
			24	76150	Schutzblech	Guard plate	Tôle de protection
			25	N2139	Sechskantschraube	Hex. screw	Vis hexagonale
			26	N26455	Schwing-Mutter	Nut	Ecrou
			27	N3957	Sechskantschraube	Hex. screw	Vis hexagonale
			28	12731	Füllventilbefestigung	Bracket for filling valve	Fixation pour robinet de rempl.
			29	N19499	Sechskantschraube	Hex. screw	Vis hexagonale



 Wartungssätze Maintenance sets Kits d'entretien			Bildtafel 78891 Figure 78891 Planche 78891	Sturzrahmen, Mariner II Protection frame, Mariner II Cadre de protection, Mariner II	<h1>TUCM-26</h1>																																			
			<table border="1"> <thead> <tr> <th colspan="3">Klasse/ Class/ Classe</th> <th>Bestell-Nr. Part No. No. de cde.</th> <th>Benennung</th> <th>Designation</th> <th>Dénomination</th> </tr> <tr> <th>a</th> <th>b</th> <th>c</th> <th>Pos.</th> <th></th> <th></th> <th></th> </tr> </thead> <tbody> <tr> <td></td> <td></td> <td></td> <td>30</td> <td>N102</td> <td>Scheibe</td> <td>Washer</td> <td>Rondelle</td> </tr> <tr> <td></td> <td></td> <td></td> <td>31</td> <td>72163</td> <td>Schutzblech</td> <td>Guard plate</td> <td>Tôle de protection</td> </tr> <tr> <td></td> <td></td> <td></td> <td>32</td> <td>N19495</td> <td>Sechskantschraube</td> <td>Hex. screw</td> <td>Vis hexagonale</td> </tr> </tbody> </table>			Klasse/ Class/ Classe			Bestell-Nr. Part No. No. de cde.	Benennung	Designation	Dénomination	a	b	c	Pos.							30	N102	Scheibe	Washer	Rondelle				31	72163	Schutzblech	Guard plate	Tôle de protection				32	N19495
Klasse/ Class/ Classe			Bestell-Nr. Part No. No. de cde.	Benennung	Designation	Dénomination																																		
a	b	c	Pos.																																					
			30	N102	Scheibe	Washer	Rondelle																																	
			31	72163	Schutzblech	Guard plate	Tôle de protection																																	
			32	N19495	Sechskantschraube	Hex. screw	Vis hexagonale																																	

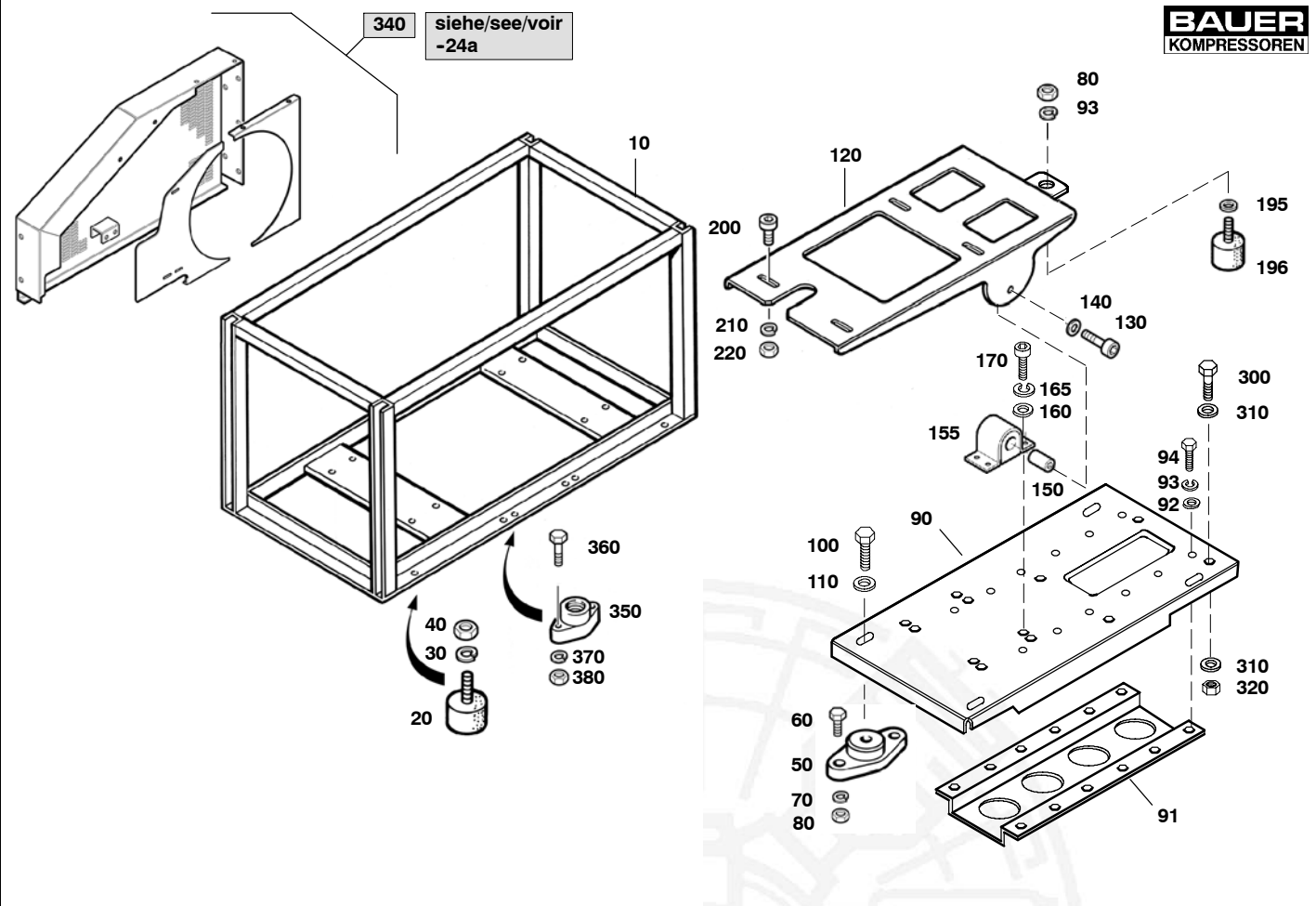

	Wartungssätze Maintenance sets Kits d'entretien	Bildtafel 79997 Figure 79997 Planche 79997	Rahmen, Utilus, Capitano, Mariner Diesel Frame, Utilus, Capitano, Mariner Diesel engine Cadre, moteur Diesel Utilus, Capitano, Mariner	TUCM-27
--	---	---	---	----------------

Klasse/ Class/ Classe			Pos.	Bestell-Nr. Part No. No. de cde.	Benennung	Designation	Dénomination
a	b	c					
			10	79843	Rahmen	frame	cadre
			20	N1547	Schwingmetall	vibration isolator	silent-bloc
			30	N177	Sechskantmutter	hexagon nut	écrou hexagonal
			40	N176	Federring	spring washer	rondelle-ressort
			50	N26164	Schwingmetall	silent-block	silent-bloc
			60	N19496	Sechskantschraube	hex screw	vis six pans
			70	N102	Scheibe	washer	rondelle
			80	N1042	Sechskantmutter	hexagon nut self-locking	écrou hexagonal auto-frein.
			90	81227	Schwingrahmen	silent-block	silent-bloc
			91	81052	Versteifung	cross beam	renfort
			92	N102	Scheibe	washer	rondelle
			93	N100	Federring	spring washer	rondelle-ressort
			94	N19496	Sechskantschraube	hex screw	vis six pans
			100	N1594	Scheibe	washer	rondelle
			110	N19519	Sechskantschraube	hex screw	vis six pans
			120	81223	Motorwippe	pedestal	bascule du moteur
			130	N19478	Zylinderschraube	screw	vis à tête cylindrique
			140	N108	Federring	spring washer	rondelle-ressort
			150	79903	Bolzen	bolt	entretoise
			155	N26577	Schwingmetall	silent block	silent-bloc
			160	N58	Scheibe	washer	rondelle
			165	N108	Federring	spring washer	rondelle-ressort
			170	N19478	Zylinderschraube	cheese head screw	vis cylindrique
			195	N26164	Schwingmetall	silent-block	silent-bloc
			196	N102	Scheibe	washer	rondelle
			200	N19478	Zylinderschraube	screw	vis à tête cylindrique
			210	N108	Federring	spring washer	rondelle-ressort
			220	N370	Sechskantmutter	hexagon nut self-locking	écrou hexagonal auto-freinant
			300	N19512	Sechskantschraube	screw	vis six pans
			310	N16	Scheibe	washer	rondelle

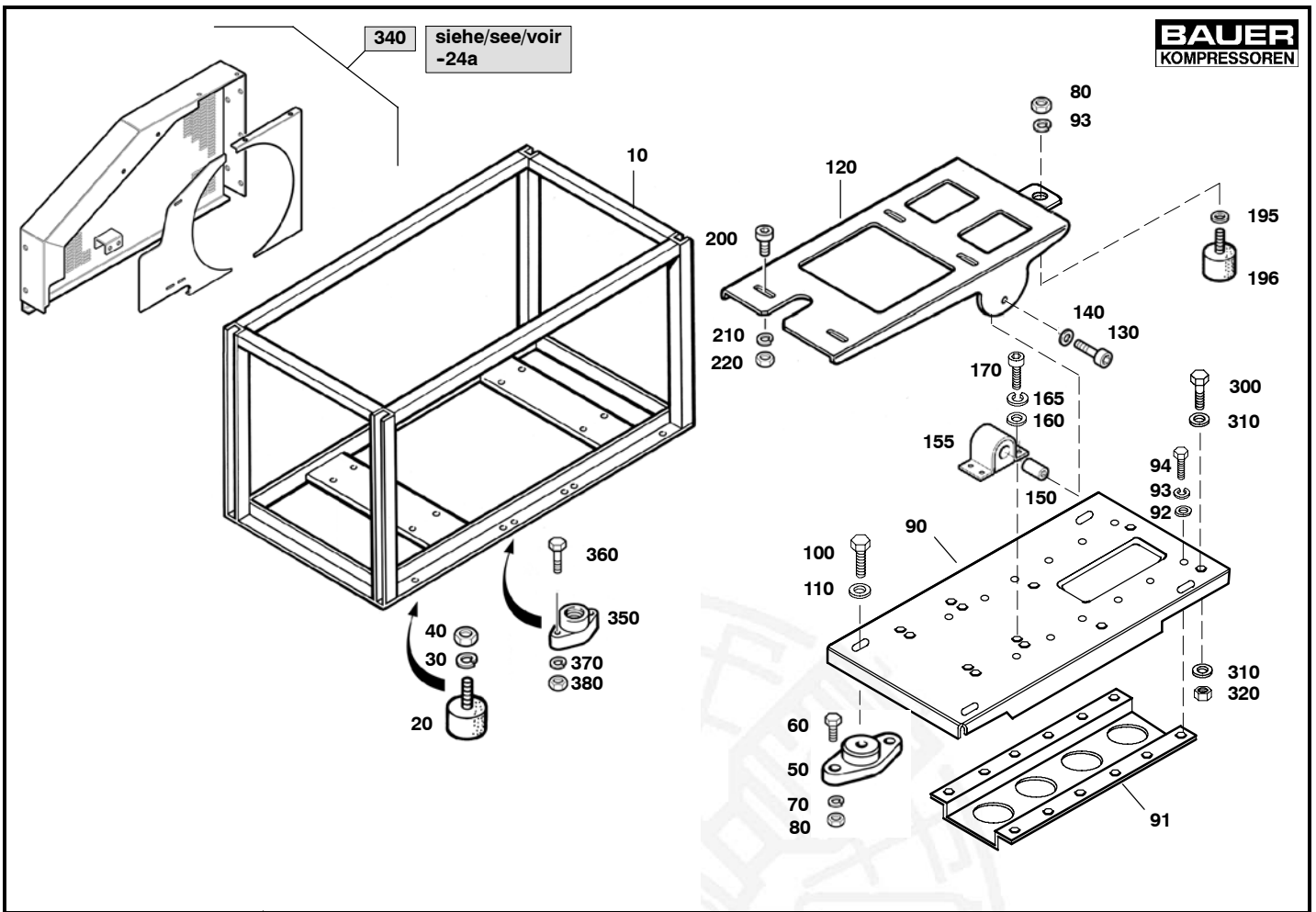

 Wartungssätze
 Maintenance sets
 Kits d'entretien

Bildtafel 79997
Figure 79997
Planche 79997

Rahmen, Utilus, Capitano, Mariner Diesel
Frame, Utilus, Capitano, Mariner Diesel engine
Cadre, moteur Diesel Utilus, Capitano, Mariner
TUCM-27

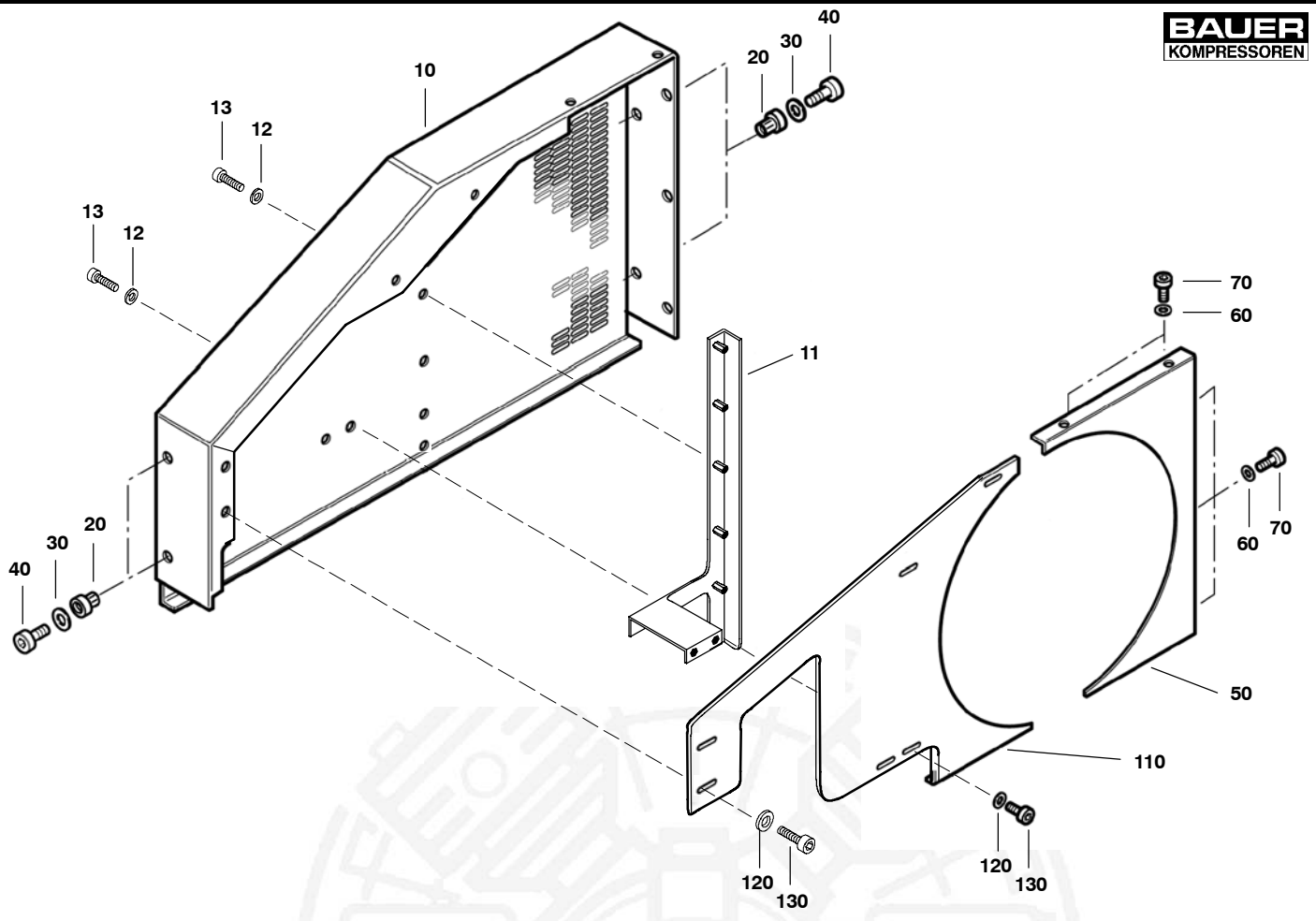
Klasse/ Class/ Classe			Pos.	Bestell-Nr. Part No. No. de cde.	Benennung	Designation	Dénomination
a	b	c					
			320	N644	Sechskantmutter	hexagon nut self-locking	écrou hexagonal auto-freinant
			340	80015	Riemenschutz kpl.	v-belt cover assy.	tôle de protection cpl.
			350	12731	Befestigung	fastening	fixation
			360	N19499	Sechskantschraube	hex screw	vis six pans
			370	N102	Scheibe	washer	rondelle
			380	N1042	Sechskantmutter	hexagon nut self-locking	écrou hexagonal auto-frein.





 Wartungssätze
 Maintenance sets
 Kits d'entretien

Bildtafel 80015 **Riemenschutz kpl.**
Figure 80015 **V-belt cover assy.**
Planche 80015 **Tôle de protection cpl.**

TUCM-27a

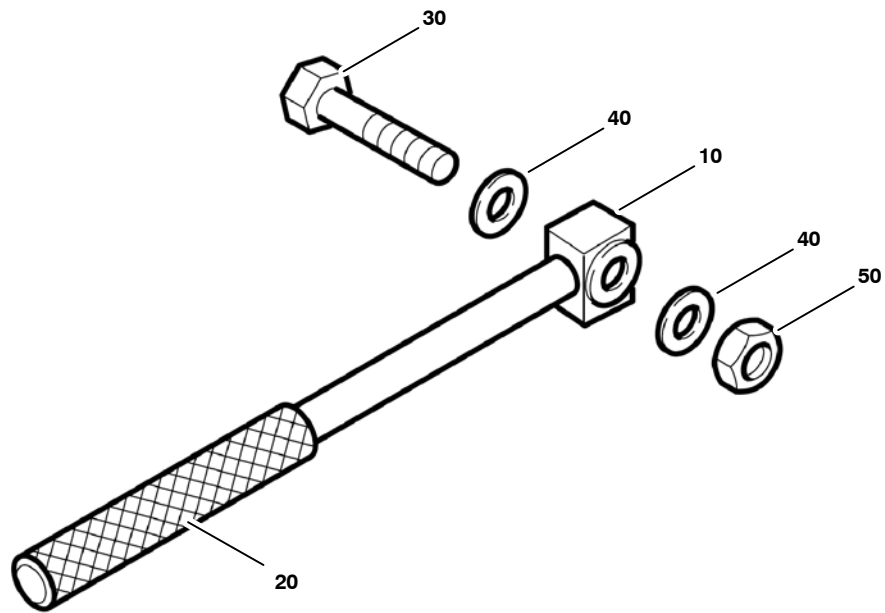
Klasse/ Class/ Classe			Pos.	Bestell-Nr. Part No. No. de cde.	Benennung	Designation	Dénomination
a	b	c					
			10	81224	Riemenschutz	v-belt cover	tôle de protection
			11	81226	Halterung für Riemenschutz	support for v-belt cover	fixation de la tôle de protection
			12	N102	Scheibe	washer	rondelle
			13	N18691	Zylinderschraube	allen screw	vis six pans creux
			20	N25809	Mutter, Flex-Loc Element	nut, Flex-Loc Element	écrou, Flex-Loc
			30	N102	Scheibe	washer	rondelle
			40	N19478	Zylinderschraube	allen screw	vis à six pans creux
			50	80016	Riemenschutz	v-belt cover	tôle de protection
			60	N102	Scheibe	washer	rondelle
			70	N18691	Zylinderschraube	allen screw	vis six pans creux
			110	81225	Riemenschutz, innen	v-belt cover, inner	tôle de protection
			120	N102	Scheibe	washer	rondelle
			130	N18691	Zylinderschraube	allen screw	vis six pans creux



Wartungssätze
 Maintenance kits
 Kits d'entretien

Baugruppe 071444
 Assembly 071444
 Assemblage 071444

Griff Kpl.
 Handle assy.
 Poignée cpl.

TUCM-28

Klasse/ Class/ Classe			Pos.	Bestell-Nr. Part No. No. de cde.	Anz. Qty. Qté.	Benennung	Designation	Dénomination
a	b	c						
			10	14005	4	Griff	handle	poignée
			20	N17059	4	Griffüberzug	handle coating	revêtement de poignée
			30	N19466	4	Schraube	screw	vis
			40	N16	8	Scheibe	washer	rondelle
			50	N644	4	Mutter	nut	écrou

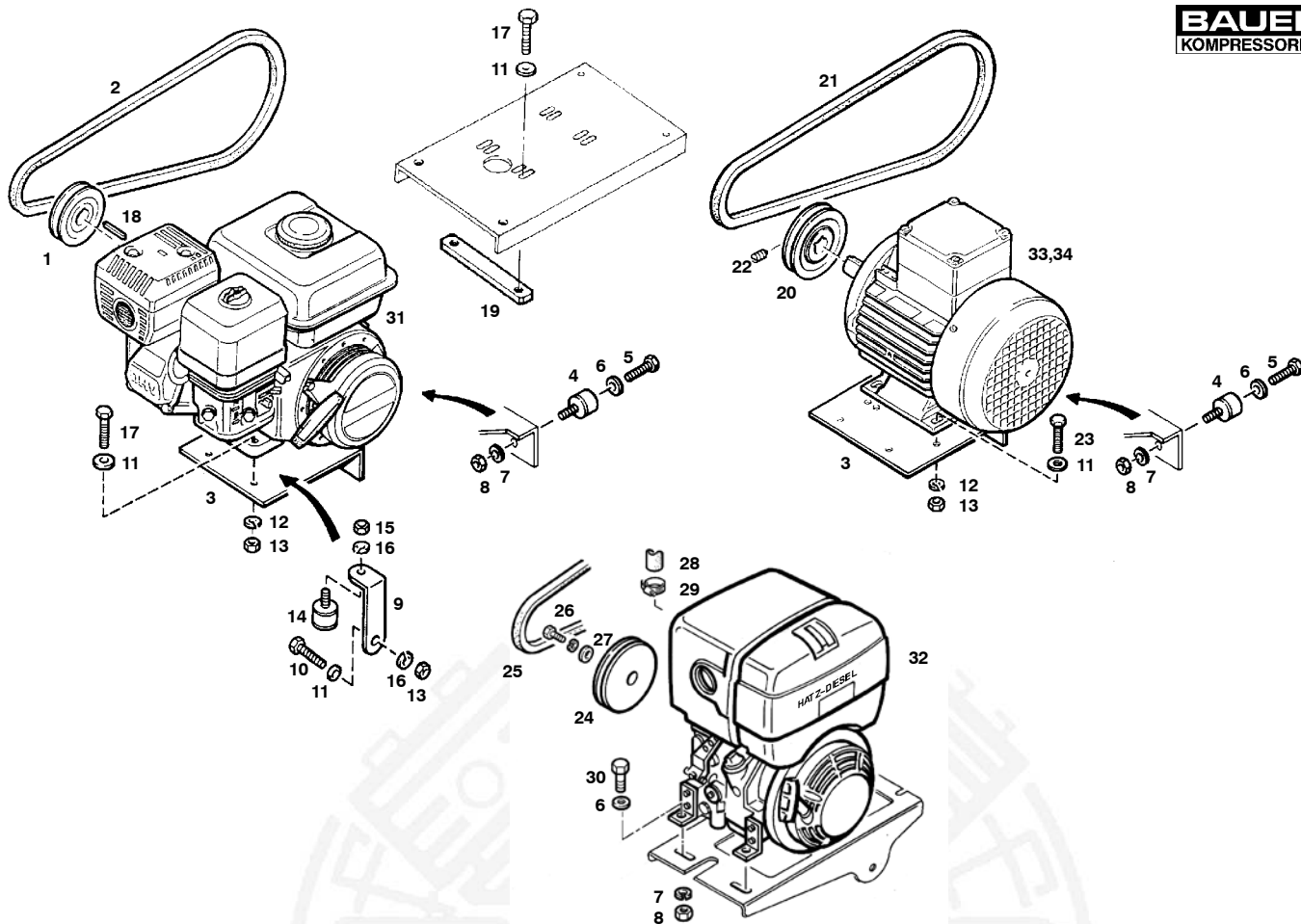



 Wartungssätze
 Maintenance sets
 Kits d'entretien

Bildtafel Mot_U II Antriebsmotoren Utilus II
Figure Mot_U II Driving motors Utilus II
Planche Mot_U II Moteurs d'entraînement Utilus II

TUCM-29

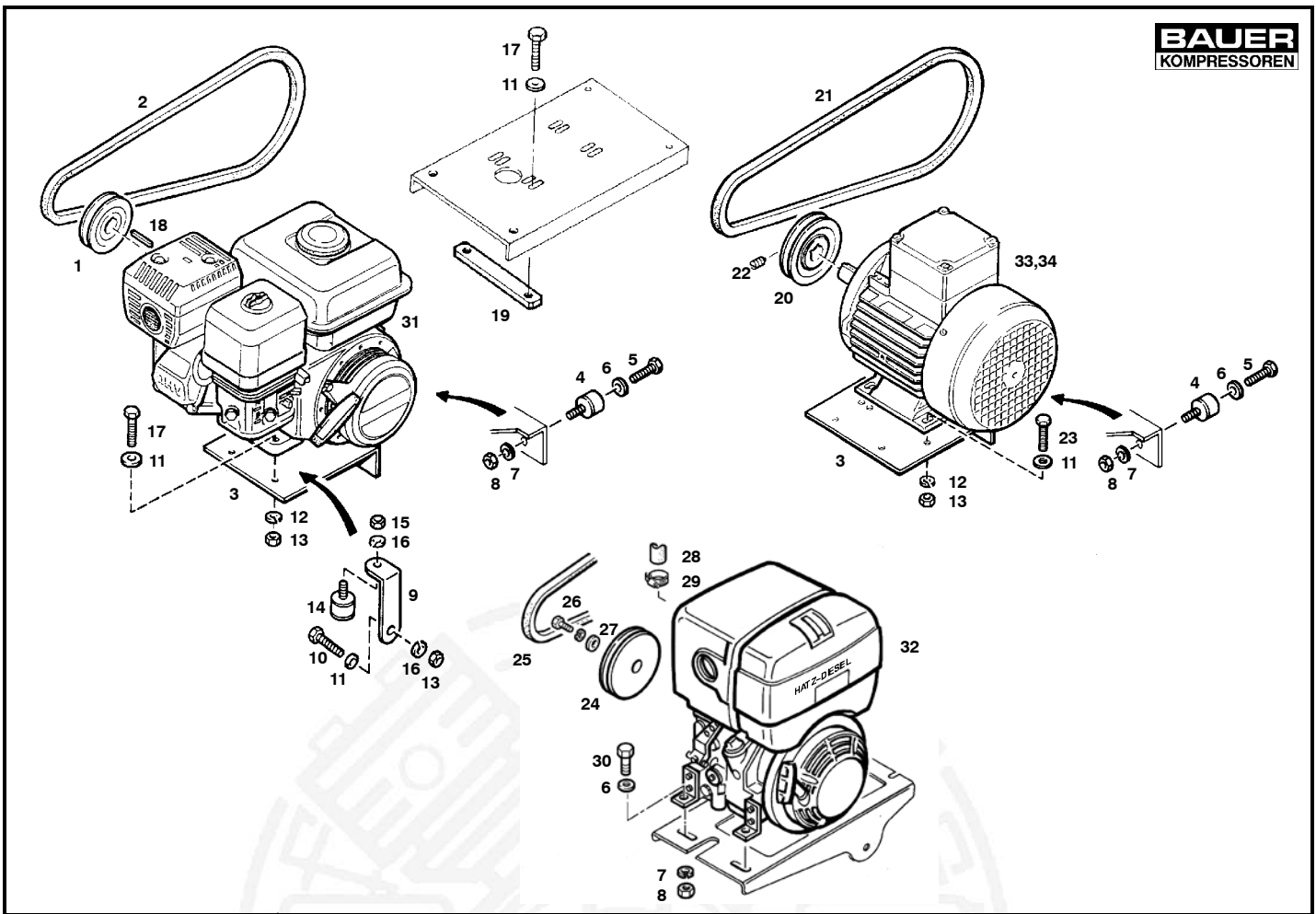
Klasse/ Class/ Classe			Pos.	Bestell-Nr. Part No. No. de cde.	Benennung	Designation	Dénomination
a	b	c					
			1	N19386	Keilriemenscheibe	V-belt pulley	Poulie à gorge
		X	2	N2594	Keilriemen	V-belt	Courroie trapézoïdale
		X	*	N2597*	Keilriemen	V-belt	Courroie trapézoïdale
			3	14349	Motorwippe	Pedestal	Moto-interrupteur à bascule
			4	N1649	Schwingmetall	Vibration isolator	Amortisseur
			5	N570	Sechskantschraube	Hex. screw	Vis hexagonale
			6	N16	Scheibe	Washer	Rondelle
			7	N176	Federring	Spring washer	Rondelle
			8	N177	Sechskantmutter	Hex. nut	Ecrou hexagonale
			9	14450	Anschlagwinkel	Bracket	fixation
			10	N19505	Sechskantschraube	Hex. screw	Vis hexagonale
			11	N58	Scheibe	Washer	Rondelle
			12	N108	Federring	Lock washer	Rondelle
			13	N57	Sechskantmutter	Hex. nut	Ecrou hexagonale
			14	N1899	Schwingmetall	Vibration isolator	Amortisseur
			15	N287	Sechskantmutter	Hex. nut	Ecrou hexagonale
			16	N100	Federring	Lock washer	Rondelle
			17	N19508	Sechskantschraube	Hex. screw	Vis hexagonale
			18	N2885	Paßfeder	Key	Clavette
			19	71700	Motorbefestigungsschiene	Motor mounting bar	Barre de fixation
			20	N17848	Keilriemenscheibe	V-belt pulley	Poulie à gorge
				N17847	Keilriemenscheibe	V-belt pulley	Poulie à gorge
		X	21	N2594	Keilriemen	V-belt	Courroie trapézoïdale
		X		N2403	Keilriemen	V-belt	Courroie trapézoïdale
		X	*	N17232*	Keilriemen	V-belt	Courroie trapézoïdale
		X	*	N2597*	Keilriemen	V-belt	Courroie trapézoïdale
			22	N106	Gewindestift	Stud	Vis sans tête
			23	N19507	Sechskantschraube	Hex. screw	Vis hexagonale
			24	80133	Keilriemenscheibe	V-belt pulley	Poulie à gorge
		X	25	N4771	Keilriemen	V-belt	Courroie trapézoïdale



Wartungssätze
Maintenance sets
Kits d'entretien

Bildtafel Mot_U II Antriebsmotoren Utilus II
Figure Mot_U II Driving motors Utilus II
Planche Mot_U II Moteurs d'entraînement Utilus II

TUCM-29

Klasse/ Class/ Classe			Pos.	Bestell-Nr. Part No. No. de cde.	Benennung	Designation	Dénomination
a	b	c					
			26	N19478	Zylinderschraube	Cylindric screw	Vis cylindrique
			27	N58	Scheibe	Washer	Rondelle
			28	N3688	Schlauch	Hose	Tuyau
			29	N3686	Schlauchklemme	Hose clamp	Pince pour tuyaux
			30	N19512	Sechskantschraube	Hex. screw	Vis hexagonale
			*		Für Sturzrahmen	For protection frame	Pour cadre de protection
			31	N20703	Benzinmotor	Petrol engine	Moteur à essence
			32	N26004	Dieselmotor	Diesel engine	Moteur Diesel
			33	N3388	Drehstrommotor	Three-phase motor	Moteur triphasé
				N21936	Drehstrommotor	Three-phase motor	Moteur triphasé
			34	N19108	Wechselstrommotor	Alternating current	Moteur à courant alternatif
				N19110	Wechselstrommotor	Alternating current	Moteur à courant alternatif
				N19111	Wechselstrommotor	Alternating current	Moteur à courant alternatif
				N19112	Wechselstrommotor	Alternating current	Moteur à courant alternatif

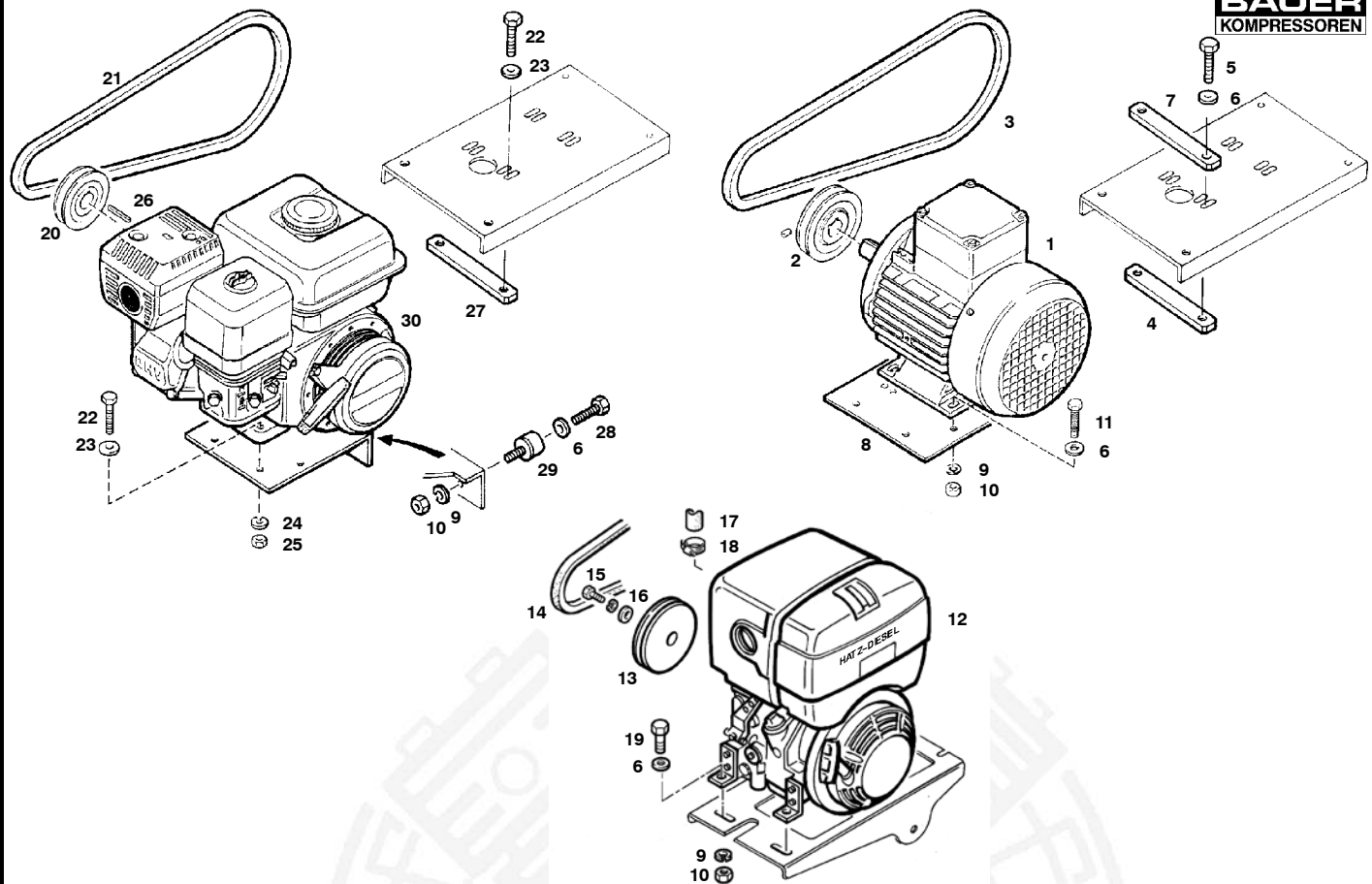
 Wartungssätze
 Maintenance sets
 Kits d'entretien

Bildtafel
Figure
Planche
Mot_C II Antriebsmotoren, Capitano II
Mot_C II Driving motors, Capitano II
Mot_C II Moteurs d'entraînement, Capitano II

TUCM-30

Klasse/ Class/ Classe			Pos.	Bestell-Nr. Part No. No. de cde.	Benennung	Designation	Dénomination
a	b	c					
			1	N2774	Drehstrommotor	Three-phase motor	Moteur triphasé
			2	6637	Keilriemenscheibe	V-belt pulley	Poulie à gorge
				55456	Keilriemenscheibe	V-belt pulley	Poulie à gorge
	X		3	*N2598	Keilriemen	V-belt	Courroie trapézoïdale
	X			*N2597	Keilriemen	V-belt	Courroie trapézoïdale
	X			N3185	Keilriemen	V-belt	Courroie trapézoïdale
	X			N2594	Keilriemen	V-belt	Courroie trapézoïdale
			4	71687	Motorbefestigungsschiene	Motor mounting bar	Barre de fixation
			5	N19514	Sechskantschraube	Hex. screw	Vis hexagonale
			6	N16	Scheibe	Washer	Rondelle
			7	72342	Distanzschiene	Spacer	Pièce d'écartement
			8	14349	Motorwippe	Pedestal	Moto-interrupteur à bascule
			9	N176	Federring	Lock washer	Ressort
			10	N177	Sechskantmutter	Hex. nut	Ecrou hexagonal
			11	N19513	Sechskantschraube	Hex. screw	Vis hexagonale
			12	N26004	Dieselmotor	Diesel engine	Moteur Diesel
			13	80054	Keilriemenscheibe	V-belt pulley	Poulie à gorge
	X		14	N4771	Keilriemen	V-belt	Courroie trapézoïdale
			15	N19478	Zylinderschraube	Cylindric screw	Vis cylindrique
			16	N58	Scheibe	Washer	Rondelle
			17	N4327	Schlauch	Hose	Tuyau
			18	N3686	Schlauchklemme	Hose clamp	Pince pour tuyaux
			19	N19512	Sechskantschraube	Hex. screw	Vis hexagonale
			20	14300	Keilriemenscheibe	V-belt pulley	Poulie à gorge
	X		21	N3185	Keilriemen	V-belt	Courroie trapézoïdale
	X			*N17232	Keilriemen	V-belt	Courroie trapézoïdale
			22	N19508	Sechskantschraube	Hex. screw	Vis hexagonale
			23	N58	Scheibe	Washer	Rondelle
			24	N108	Federring	Lock washer	Ressort
			25	N57	Sechskantmutter	Hex nut	Ecrou hexagonal

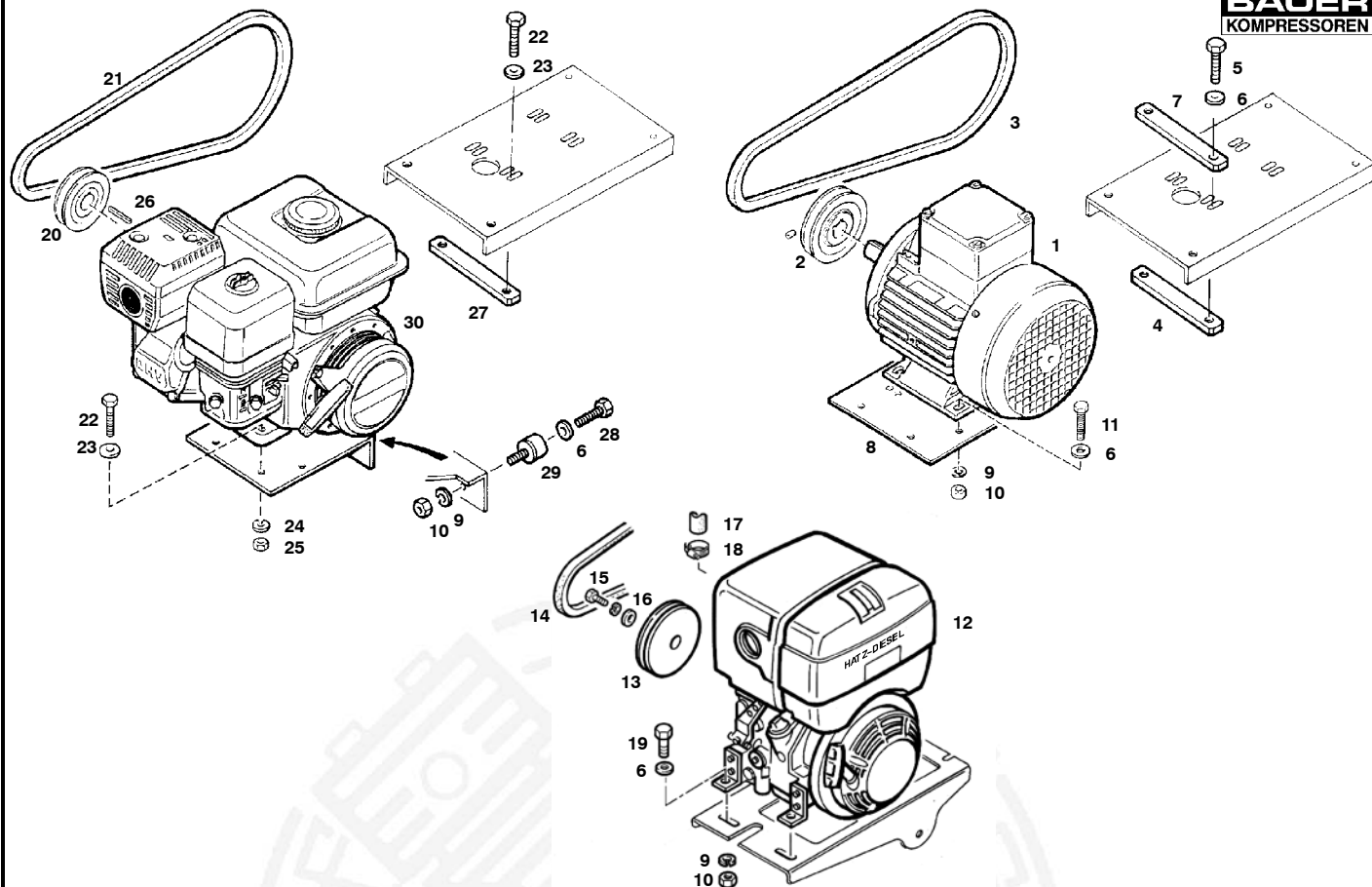

Wartungssätze
 Maintenance sets
 Kits d'entretien

Bildtafel Mot_C II Antriebsmotoren, Capitano II
Figure Mot_C II Driving motors, Capitano II
Planche Mot_C II Moteurs d'entraînement, Capitano II

TUCM-30

Klasse/ Class/ Classe			Pos.	Bestell-Nr. Part No. No. de cde.	Benennung	Designation	Dénomination
a	b	c					
			26	N2885	Paßfeder	Key	Clavette
			27	71700	Motorbefestigungsschiene	Motor mounting bar	Barre de fixation
			28	N570	Sechskantschraube	Hex. screw	Vis hexagonale
			29	N1649	Schwingmetall	Vibration isolator	Amortisseur
			30	N20703	Benzinmotor	Petrol engine	Moteur à essence
			*		Für Sturzrahmen	For protection frame	Pour cadre de protection

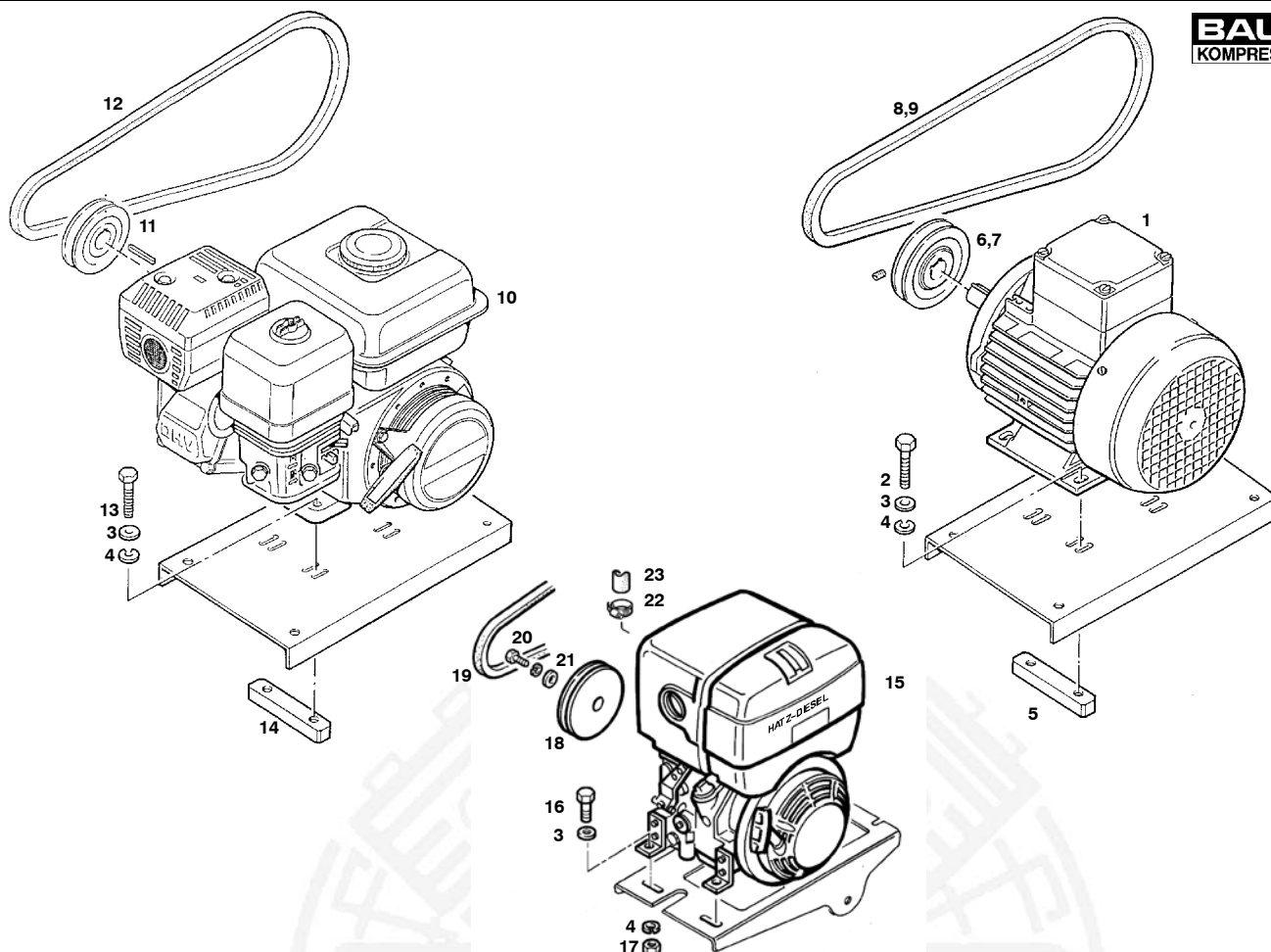
 Wartungssätze
 Maintenance sets
 Kits d'entretien

Bildtafel Mot_M II Antriebsmotoren Mariner II
Figure Mot_M II Driving motors Mariner II
Planche Mot_M II Moteurs d'entraînement Mariner II

TUCM-31

Klasse/ Class/ Classe			Pos.	Bestell-Nr. Part No. No. de cde.	Benennung	Designation	Dénomination
a	b	c					
			1	N3390	Drehstrommotor	Three-phase motor	Moteur triphasé
				N16727	Drehstrommotor	Three-phase motor	Moteur triphasé
			2	N19514	Sechskantschraube	Hex. screw	Vis hexagonale
			3	N16	Scheibe	Washer	Rondelle
			4	N176	Federring	Lock washer	Rondelle élastique
			5	71687	Motorbefestigungsschiene	Motor mounting bar	Barre de fixation
			6	6637	Keilriemenscheibe	V-belt pulley	Poulie à gorge
			7	55456	Keilriemenscheibe	V-belt pulley	Poulie à gorge
	X		8	N2598	Keilriemen	V-belt	Courroie trapézoïdale
	X		9	N2597	Keilriemen	V-belt	Courroie trapézoïdale
			10	N19887	Benzinmotor	Petrol engine	Moteur à essence
			11	78888	Keilriemenscheibe	V-belt pulley	Poulie à gorge
	X		12	N17232	Keilriemen	V-belt	Courroie trapézoïdale
			13	N19515	Sechskantschraube	Hex. screw	Vis hexagonale
			14	71687	Motorbefestigungsschiene	Motor mounting bar	Barre de fixation
			15	N26004	Dieselmotor	Diesel engine	Moteur Diesel
			16	N19512	Sechskantschraube	Hex. screw	Vis hexagonale
			17	N177	Sechskantmutter	Hex. nut	Ecrou hexagonal
			18	80054	Keilriemenscheibe	V-belt pulley	Poulie à gorge
	X		19	N4771	Keilriemen	V-belt	Courroie trapézoïdale
			20	N19478	Zylinderschraube	Cylindric screw	Vis cylindrique
			21	N58	Scheibe	Washer	Rondelle
			22	N3686	Schlauchklemme	Hose clamp	Collier pour tuyau
			23	N3688	Schlauch	Hose	Tuyau

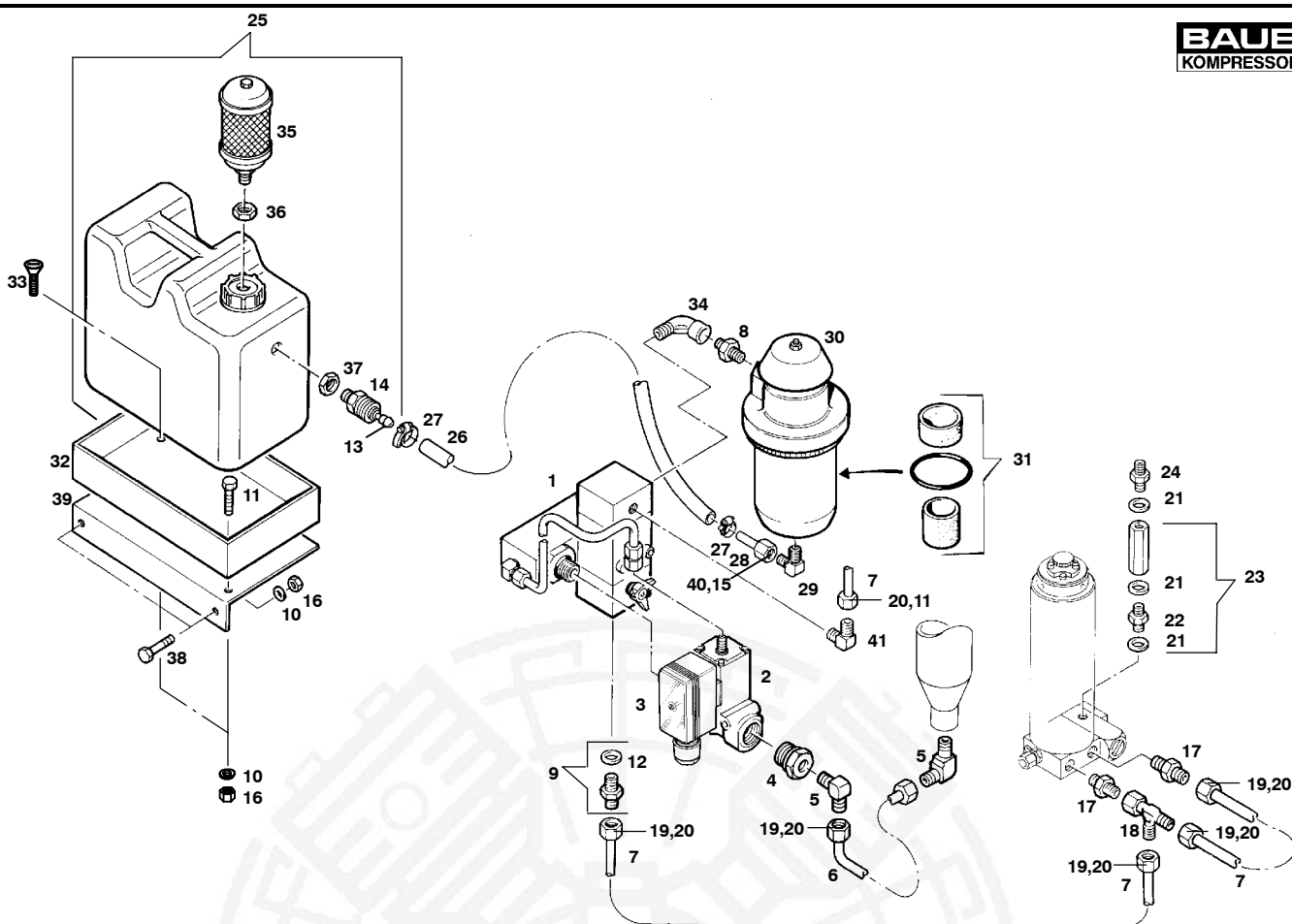
 Wartungssätze
 Maintenance sets
 Kits d'entretien

Bildtafel 068222 **Kondensatablaßautomatik kpl. (Zusatzausstattung)**
Figure 068222 **Automatic condensate drain (optional extra)**
Planche 068222 **Purge automatique des condensats (optionnelle)**
TUCM-32

Klasse/ Class/ Classe			Pos.	Bestell-Nr. Part No. No. de cde.	Benennung	Designation	Dénomination
a	b	c					
			1	063760	Kondensatablaßventil kpl.	Condensate drain valve assy.	Soup. de purge des cond. cpl.
			2	**N16270	Zwei-Wege-Magnetventil 220 V, 40-60 Hz	2-way solenoid valve 220 V, 40-60 Hz	Electrovanne 2 voies 220 V, 40-60 Hz
				**N16382	Zwei-Wege-Magnetventil 115 V, 50-60 Hz	2-way solenoid valve 115 V, 50-60 Hz	Electrovanne 2 voies 115 V, 50-60 Hz
				**N16384	Zwei-Wege-Magnetventil 240 V, 50-60 Hz	2-way solenoid valve 240 V, 50-60 Hz	Electrovanne 2 voies 240 V, 50-60 Hz
				**N16381	Zwei-Wege-Magnetventil 12 V DC	2-way solenoid valve 12 V DC	Electrovanne 2 voies 12 V DC
				**N16387	Zwei-Wege-Magnetventil 24 V DC	2-way solenoid valve 24 V DC	Electrovanne 2 voies 24 V DC
				**N18364	Zwei-Wege-Magnetventil 24 V AC	2-way solenoid valve 24 V AC	Electrovanne 2 voies 24 V AC
			3	N22582	Laufschahtwerk 110-230 V AC	Electrical timer 110-230 V AC	Minuterie électrique 110-230 V AC
				N22581	Laufschahtwerk 12-24 V DC	Electrical timer 12-24 V DC	Minuterie électrique 12-24 V DC
				N22584	Laufschahtwerk 24-48 V AC/DC	Electrical timer 24-48 V AC/DC	Minuterie électrique 24-48 V AC/ DC
			4	N9155	Reduzierung	Reducer	Réducteur
			5	N20001	Winkelrohrverschraubung	Male elbow	Raccord coudé mâle
			6	*N3616	Verbindungsleitung	Connecting tube	Conduite de connexion
			7	*N3617	Verbindungsleitung	Connecting tube	Conduite de connexion
			8	N3734	Doppelnippel	Nipple	Pièce intermédiaire
			9	78791	Rohrverschraubung mit Düse	Connector with nozzle	Pièce intermédiaire avec buse
			10	N100	Federring	Spring washer	Rondelle élastique
			11	N7430	Überwurfmutter	Cap screw	Ecrou
			12	N25108	Dichtung	Gasket	Joint
			13	N17180	Stecktülle	Connector	Connecteur mâle-femelle
			*		Meterware; bei Bestellung Länge angeben	Piece goods; specify lenght on order	Marchandise au mètre; indiquer la longueur à la cde.

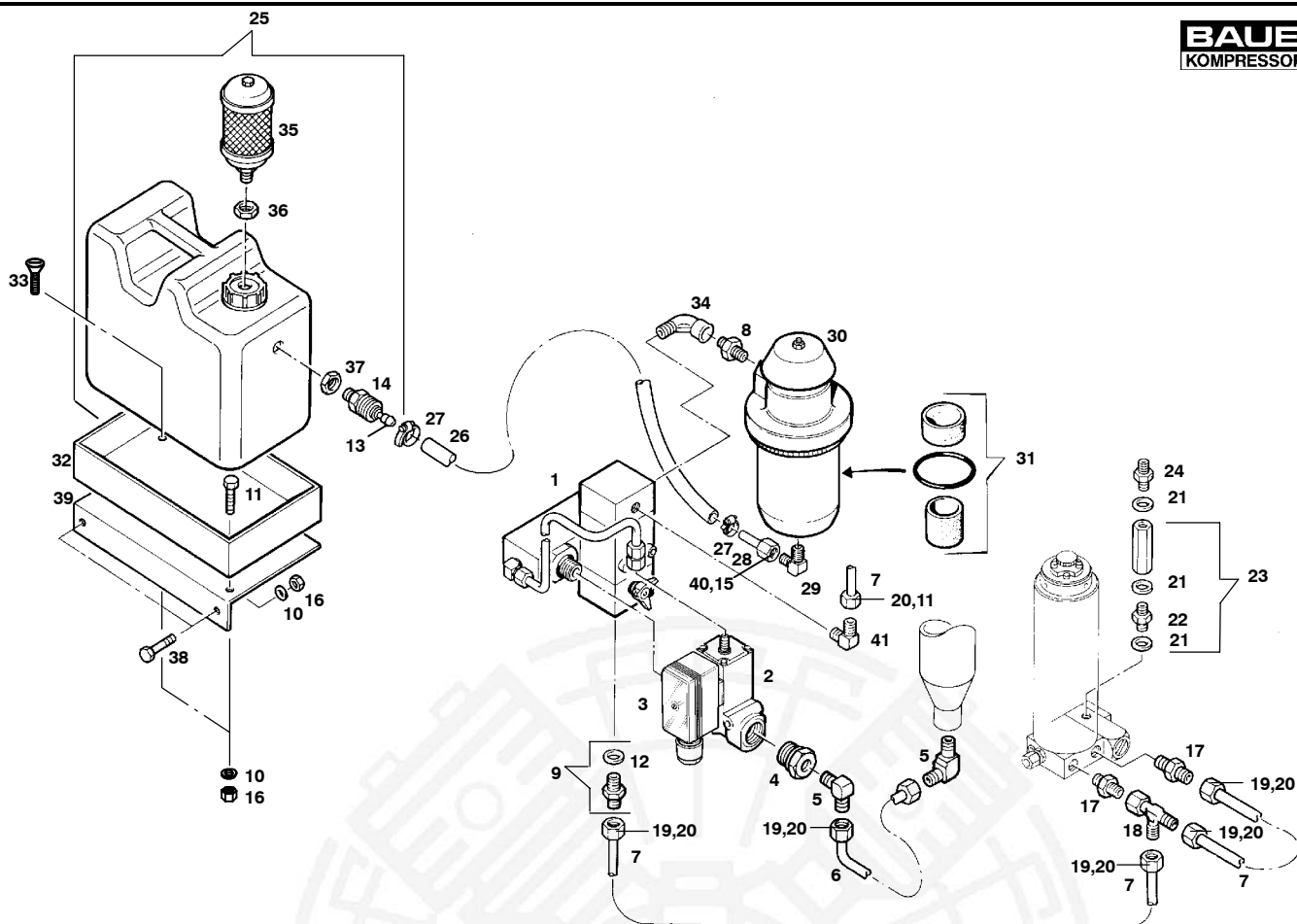



Wartungsätze
 Maintenance sets
 Kits d'entretien

Bildtafel 068222 **Kondensatablaßautomatik kpl. (Zusatzausstattung)**
Figure 068222 **Automatic condensate drain (optional extra)**
Planche 068222 **Purge automatique des condensats (optionnelle)**

TUCM-32

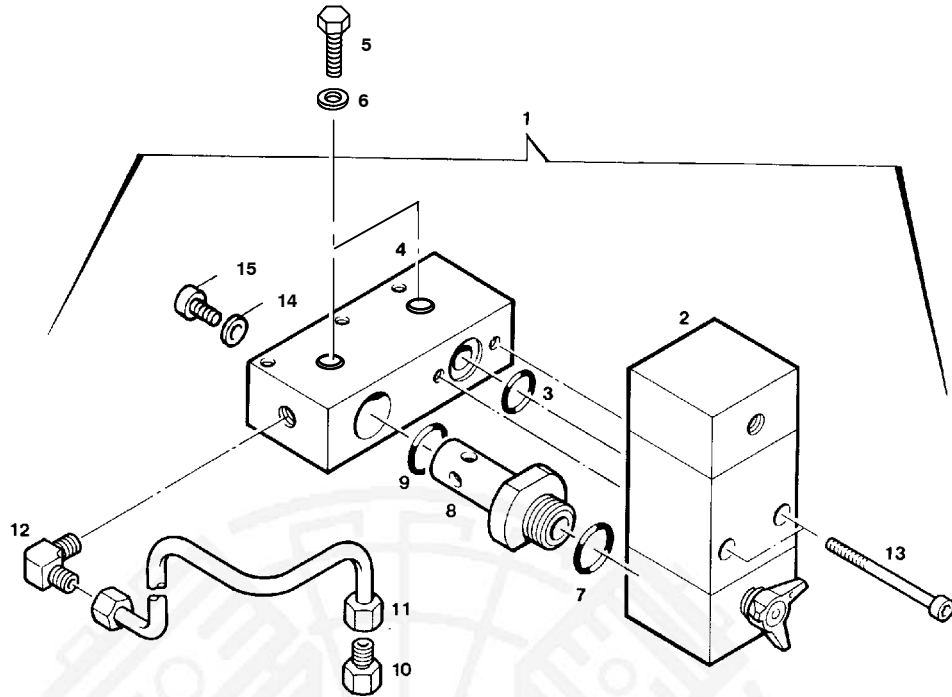
Klasse/ Class/ Classe			Pos.	Bestell-Nr. Part No. No. de cde.	Benennung	Designation	Dénomination
a	b	c					
				**	Bei Bestellung Spannung und Frequenz angeben	Please specify voltage and frequency on order	Indiquer le voltage et la fréquence à la cde.
			14	N17179	Schnellkupplung	Quick-coupling	Raccord rapide
			15	N3609	Schneidring	Compression ring	Bague coupante
			16	N287	Sechskantmutter	Hex. screw	Vis hexagonale
			17	63666	Anschlußstück für Triplex	Adapter for Triplex filter	Pièce de raccordement
			18	N20185	Einstellbarer L-Stutzen	Adjustable male run L	Raccord en L orientable
			19	N3610	Überwurfmutter	Cap screw	Écrou
			20	N3663	Schneidring	Compression ring	Bague coupante
			21	N4602	USIT-Ring	USIT ring	Joint USIT
			22	9068	Doppelnippel	Adapter	Pièce intermédiaire
			23	072311	Rückschlagventil	Non-return valve	Clapet anti-retour
			24	65363	UNIMAM-Verschraubung	UNIMAM connector	Raccord UNIMAM
			25	067048	Kondensatbehälter kpl.	Condensate collector assy.	Récepteur de condensats cpl.
			26	N3126	Schlauch	Hose	Tuyau
			27	N3133	Schlauchklemme	Hose clamp	Collier pour tuyaux
			28	N3618	Rohrstück	Tube	Tube
			29	N1536	Winkelrohrverschraubung	Male elbow	Raccord coudé mâle
			30	067050	Filter-Schalldämpfer	Filter silencer	Silencieux de filtre
			31	N15052	Reparatursatz	Maintenance kit	Kit de réparation
			32	63702	Halterung	Bracket	Fixation
			33	N159	Senkkopfschraube	Countersunk screw	Vis à tête fraisée
			34	N24722	Winkel	Elbow	Raccord coudé
			35	N1139	Schalldämpfer	Silencer	Silencieux
			36	N2953	Gegenmutter zu Pos. 35	Counter nut for pos. 35	Contre-écrou pour pos. 35
			37	N17448	Gegenmutter zu Pos. 14	Counter nut for pos. 14	Contre-écrou pour pos. 14
			38	N19496	Sechskantschraube	Hex. screw	Vis hexagonale
			39	71143	Befestigungswinkel	Bracket	Equerre de fixation
			40	N1049	Überwurfmutter	Cap screw	Écrou
			41	N20003	Winkelrohrverschraubung	Male elbow	Raccord coudé mâle



TUCM-33

 Wartungssätze
 Maintenance sets
 Kits d'entretien

Bildtafel	063760	Kondensatablaßventil KB 063760 kpl.
Figure	063760	Condensate drain valve KB 063760 assy.
Planche	063760	Soupape de purge des condensats KB 063760

Klasse/ Class/ Classe			Pos.	Bestell-Nr. Part No. No. de cde.	Benennung	Designation	Dénomination
a	b	c					
			1	063760	Kondensatablaßventil, kpl.	Condensate drain valve assy.	Soup. de purge des cond. cpl.
			2	075169	Kondensatablaßventil	Condensate drain valve	Soupape de purge des cond.
	X		3	N638	O-Ring	O-ring	Joint torique
			4	64006	Sammelleiste	Manifold	Listeau collecteur
			5	N19494	Sechskantschraube	Hex. screw	Vis hexagonale
			6	N102	Scheibe	Washer	Rondelle
	X		7	N2320	O-Ring	O-ring	Joint torique
			8	64004	Ventilverbindung	Valve connection	Raccord de soupape
	X		9	N2507	O-Ring	O-ring	Joint torique
			10	64010	Gerade Rohrverschraubung	Male connector	Raccord droit mâle
			11	*N3616	Verbindungsleitung	Connection	Conduite de connexion
			12	N683	Winkelrohrverschraubung	Male elbow	Raccord coudé mâle
	X		13	N724	Innensechskantschraube	Allen screw	Vis à six pans creux
			14	N3625	Dichtung	Gasket	Joint
			15	N829	Innensechskantschraube	Allen screw	Vis à six pans creux
			*		Meterware; bei Bestellung Länge angeben	Piece goods; specify length on order	Marchandise au mètre; indiquer la longueur à la commande

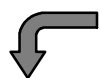
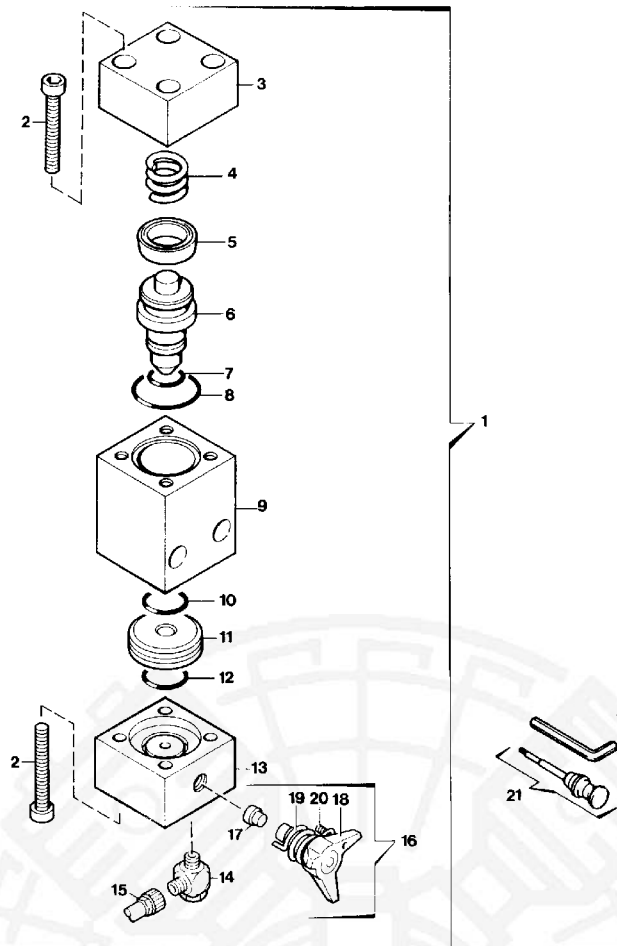
 Wartungssätze
 Maintenance sets
 Kits d'entretien

Bildtafel 075169 Kondensatablaßventil KB 075169 kpl.
Figure 075169 Condensate drain valve KB 075169 assy.
Planche 075169 Soupape de purge des condensats KB 075169
TUCM-34

Klasse/ Class/ Classe			Pos.	Bestell-Nr. Part No. No. de cde.	Benennung	Designation	Dénomination
a	b	c					
			1	075169	Kondensatablaßventil	Condensate drain valve	Soupape de purge des cond.
			2	N19536	Innensechskantschraube	Allen screw	Vis à six pans creux
			3	64000	Kopfteil	Top flange	Bride supérieure
			4	64011	Feder	Spring	Ressort
X			5	N16269	Nutring	Sealing ring	Gague d'étanchéité
	X		6	64003	Kolben	Piston	Piston
X			7	N638	O-Ring	O-ring	Joint torique
X			8	N4881	O-Ring	O-ring	Joint torique
			9	64001	Mittelteil	Valve body	Corps de soupape
X			10	N2507	O-Ring	O-ring	Joint torique
X			11	75168	Ventilsitz	Valve seat	Siège de soupape
X			12	N4496	O-Ring	O-ring	Joint torique
			13	64002	Fußteil	Base flange	Bride inférieure
			14	N16334	Schwenkverschraubung	Adjustable male branch T	Raccord en T orientable
			15	N15088	Schlauch	Hose	Tuyau
			16	065500	Knebelschraube kpl.	Drain tap assy.	Robinet cpl.
			17	64498-S01	Dichtung	Gasket	Joint
			18	11392	Knebelschraube	Drain tap	Robinet
			19	65310	Schenkelfeder	Spring	Ressort à branches
			20	N16947	Gewindestift	Stud	Vis sans tête
			21	067458	Werkzeugsatz f. Knebel- schraube	Tool set for drain tap	Jeu d'outils pour robinet

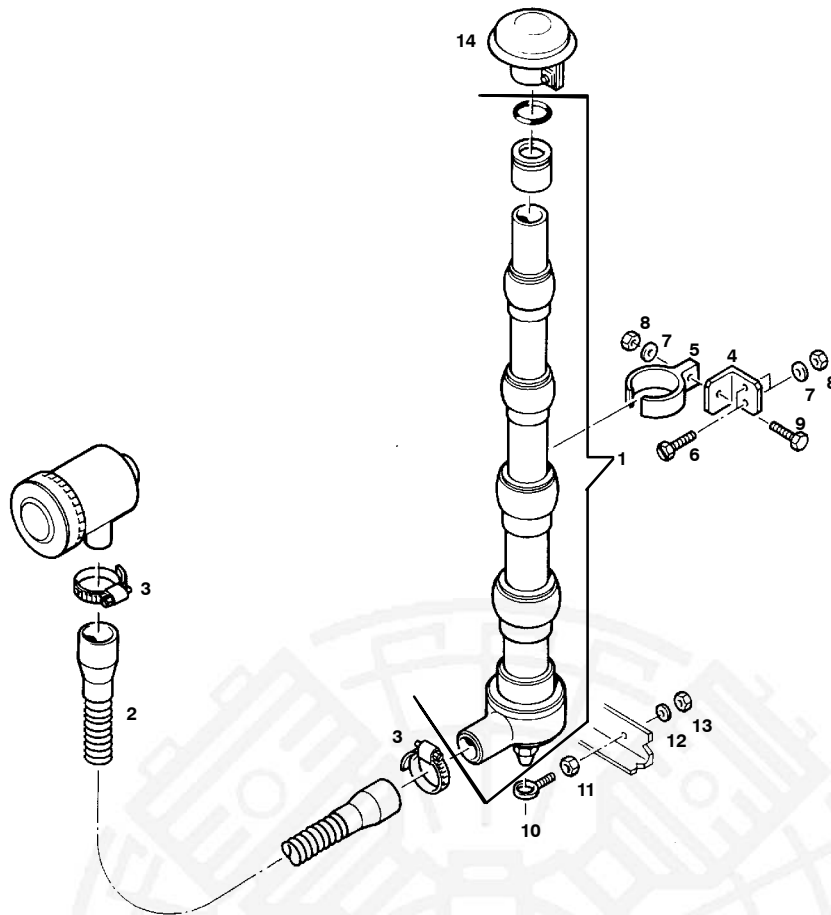
 Wartungssätze
 Maintenance sets
 Kits d'entretien

Bildtafel 055125
Figure 055125
Planche 055125
Ansaugteleskop mit Anschlussstücken
Intake pipe with connecting parts
Conduite d'aspiration avec pièces de raccordement
TUCM-35

Klasse/ Class/ Classe			Pos.	Bestell-Nr. Part No. No. de cde.	Benennung	Designation	Dénomination
a	b	c					
			1	055147	Ansaugteleskop kpl.	Intake pipe assy.	Conduite d'aspiration cpl.
			2	N3749	Schlauch	Tube	Tuyau
			3	N2011	Schlauchklemme	Hose clamp	Collier pour tuyaux
			4	55940	Haltewinkel	Bracket	Fixation
			5	N3903	Rohrclip	Clamp	Collier pour tuyaux
			6	N19481	Senkkopfschraube	Countersunk screw	Vis à tête fraisée
			7	N100	Federring	Lock washer	Rondelle élastique
			8	N287	Sechskantmutter	Hex. nut	Ecrou hexagonal
			9	N19509	Sechskantschraube	Hex. screw	Vis hexagonale
			10	N3682	Ringschraube	Eyebolt	Anneau à vis
			11	N57	Sechskantmutter	Hex. nut	Ecrou hexagonal
			12	N108	Federring	Lock washer	Rondelle élastique
			13	N19505	Sechskantmutter	Hex. nut	Ecrou hexagonal
			14	N3480	Regenkappe	Cover	Couvercle

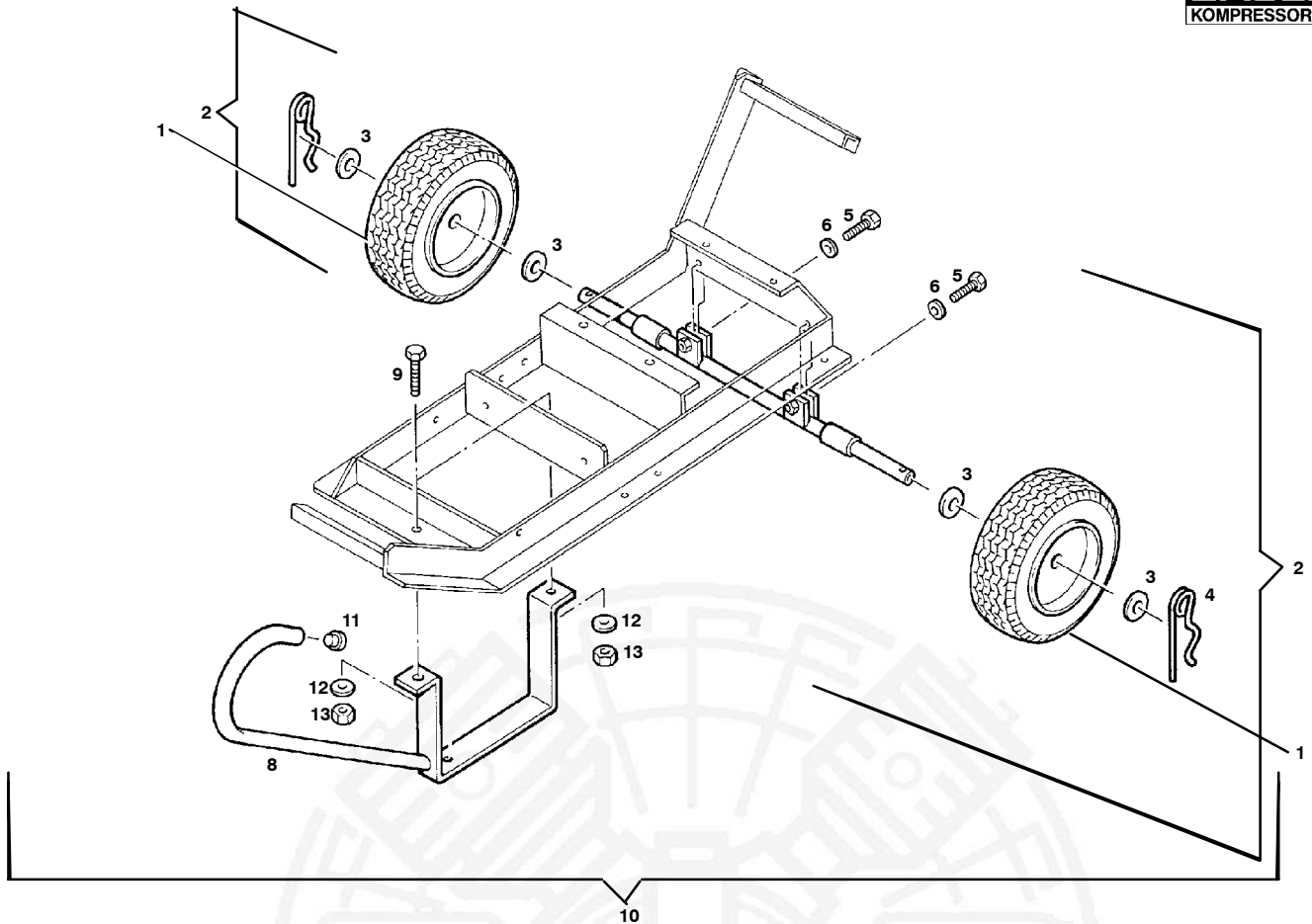
 Wartungssätze
 Maintenance sets
 Kits d'entretien

Bildtafel 78838
Figure 78838
Planche 78838

Fahrsatz (Zusatzausstattung)
Undercarriage (optional extra)
Chariot (option)
TUCM-36

Klasse/ Class/ Classe			Pos.	Bestell-Nr. Part No. No. de cde.	Benennung	Designation	Dénomination
a	b	c					
			1	N3772	Reifen	Wheel	Pneu
			2	78837	Radachse kpl.	Wheel axle assy.	Essieu cpl.
			3	N1222	Scheibe	Washer	Rondelle
			4	N3773	Federsplint	Spring cotter	Goupille
			5	N19506	Sechskantschraube	Hex. screw	Vis hexagonale
			6	N108	Federring	Spring	Ressort
			7	N177	Sechskantmutter	Hex. nut	Ecrou hexagonal
			8	55077	Fahrsatzfuß	Undercarriage leg	Pied du chariot
			9	N19512	Sechskantschraube	Hex. screw	Vis hexagonale
			10	78838	Fahrsatz kpl.	Undercarriage assy.	Chariot cpl.
			11	N3774	Schutzstopfen	Plug	Bouchon
			12	N16	Scheibe	Washer	Rondelle
			13	N176	Federring	Lock washer	Rondelle élastique

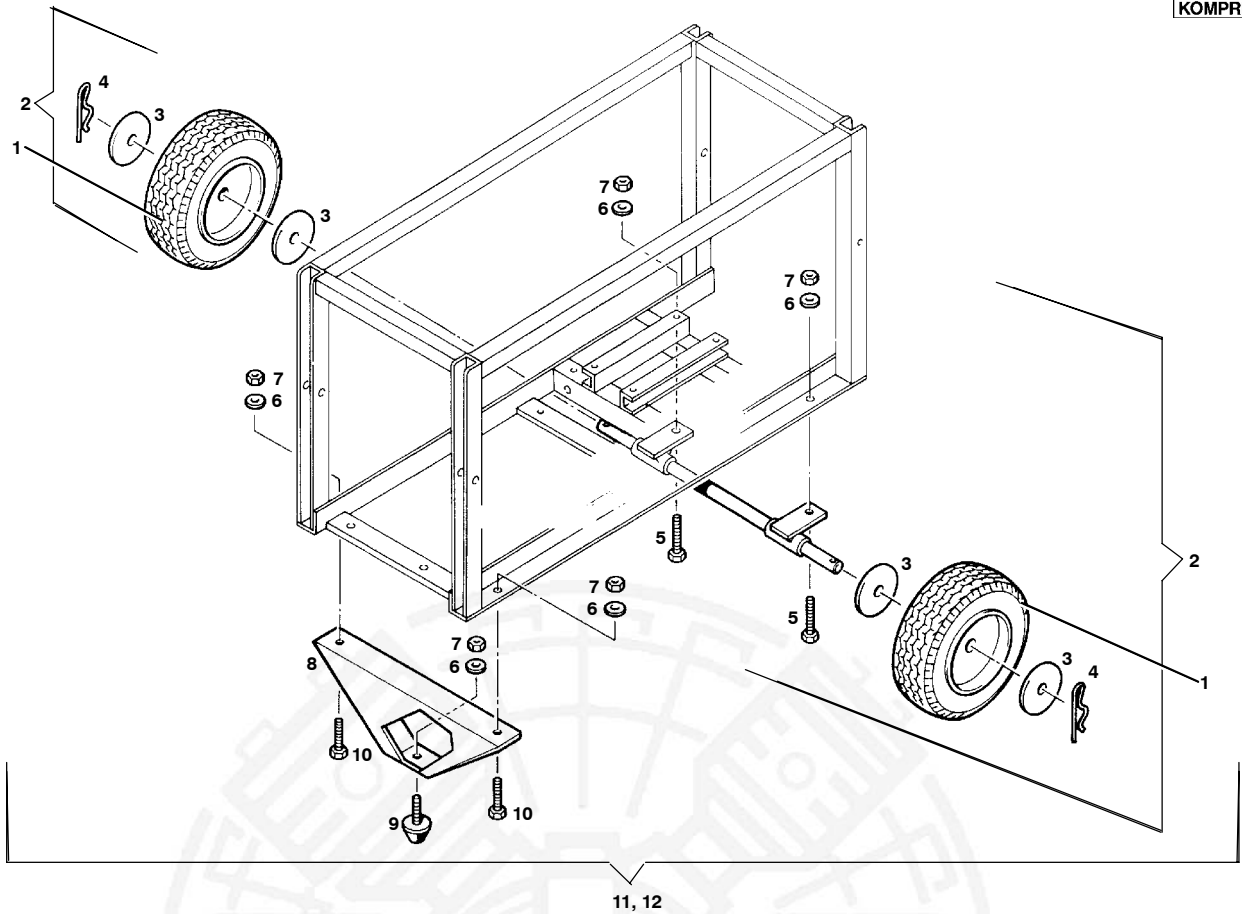
 Wartungssätze
 Maintenance sets
 Kits d'entretien

Bildtafel 78836
Figure 78836
Planche 78836

Fahrsatz (Zusatzausstattung)
Undercarriage (optional extra)
Chariot (option)
TUCM-37

Klasse/ Class/ Classe			Pos.	Bestell-Nr. Part No. No. de cde.	Benennung	Designation	Dénomination
a	b	c					
			1	N3772	Reifen	Wheel	Pneu
			2	78835	Radachse kpl.	Wheel axle assy.	Essieu cpl.
			3	N1222	Scheibe	Washer	Rondelle
			4	N3773	Federsplint	Spring cotter	Goupille
			5	N19513	Sechskantschraube	Hex. screw	Vis hexagonale
			6	N176	Federring	Lock washer	Rondelle élastique
			7	N177	Sechskantmutter	Hex. nut	Ecrou hexagonal
			8	78834	Fahrsatzfuß	Undercarriage leg	Pied du chariot
			9	N1547	Anschlagpuffer	Buffer stop	Tampom amortisseur
			10	N19512	Sechskantschraube	Hex. screw	Vis hexagonale
			11	78836	Fahrsatz kpl.	Undercarr. assy.	Chariot cpl.

