

**Ersatzteilliste**  
**Spare parts catalogue**  
**Catalogue des pièces**

---

# **TM320-2/0**

**Atemluft-Kompressoranlagen**  
**Breathing air compressor units**  
**Groupes compresseurs à air respirable**

## **Mariner 320**





## TEILELISTE TM320-2/0

ist gültig ab **Januar 2004**  
für Kompressor typ

**MARINER 320**

## PARTS LIST TM320-2/0

is valid as of **January 2004**  
for compressor model

**MARINER 320**

## CATALOGUE DES PIECES TM320-2/0

est valable à partir de **Janvier 2004**  
pour les compresseurs de type

**MARINER 320**

<b>Baugruppe</b>	<b>Assembly</b>	<b>Assemblage</b>	<b>Abb./fig.</b>
Kurbelgehäuse mit Zubehör	Crankcase with accessories	Carter avec accessoires	TM320-1
Triebwerk	driving gear	embiellage	
Kolben, Zylinder 1./2. Stufe	Pistons, cylinders 1st/2nd stage	Pistons, cylindres 1e/2e étage	TM320-2
Kolben, Zylinder 3. Stufe	Pistons, cylinders 3rd stage	Pistons, cylindres 3e étage	TM320-3
Kolben, Zylinder 4. Stufe	Pistons, cylinders 4th stage	Pistons, cylindres 4e étage	TM320-4
Ventilkopf, 1. Stufe	Valve head, 1st stage	Culasse de 1er étage	TM320-5
Ventilkopf, 2. Stufe	Valve head, 2nd stage	Culasse de 2e étage	TM320-6
Ventilkopf, 3. Stufe	Valve head, 3rd stage	Culasse de 3e étage	TM320-7
Ventilkopf, 4. Stufe	Valve head, 4th stage	Culasse de 4e étage	TM320-8
Schwungrad	Flywheel	Volant	TM320-9
Zwischenfilter	Intermediate separator valves	Séparateur intermédiaire	TM320-10
Zwischenfilter	Intermediate separator valves	Séparateur intermédiaire	TM320-11
Kühlung	Cooling system	Refroidissement	TM320-12
Druckölschmierung	Lubrication system	Lubrification	TM320-13
Ansaugfilter	Intake filter	Filtere d'aspiration	TM320-14
Kondensatablaßhahn	Condensate drain tap	Robinete de purge des condensats	TM320-15
Filtersystem P31	Filter system P31	Système de filtration P31	TM320-16
Filtersystem P41*	Filter system P41*	Système de filtration P41*	TM320-17
Fülleiste	Filling panel	Listeau de remplissage	TM320-18
Fülleiste mit Umschalt einrichtung*	Filling panel with change over device*	Listeau de remplissage / dispositif sélecteur*	TM320-19
Fülleinrichtung 200 bar	Filling device 200 bar	Dispositif de remplissage 200 bar	TM320-20
Fülleinrichtung 300 bar	Filling device 300 bar	Dispositif de remplissage 300 bar	TM320-21
Rahmen	Frame	Châssis	TM320-22
Antriebsmotoren und Zubehör	Driving motors and accessories	Moteurs d'entraînement et accessoires	TM320-23
Kondensatablaßautomatik*	Automatic condensate drain*	Purge automatique des condensats*	TM320-24
Fahrsatz*	Undercarriage*	Chariot*	TM320-25
Elektrische Steuerung*	Electric control system*	Commande électrique*	TM320-26

\*Zusatzausstattung ..... \*Optional extra ..... \*Optionnel

**Wichtige Hinweise für Teilebestellung:**

Bestell-Nr., die mit der Ziffer 0 beginnen, bezeichnen Baugruppen, die komplett geliefert werden. Teile ohne Bestell-Nr. sind nur zur Information für die Montage aufgeführt. Sie sind nicht als Ersatzteil erhältlich. Bei Ersatzteilbestellungen erwarten Sie unsere richtige Lieferung; deshalb benötigen wir von Ihnen folgende Angaben (siehe unten gezeigtes Typenschild):

1. Modellbezeichnung, Fabrik-Nr. sowie Fertigungsstand von Anlage/Block
2. Stückzahlen
3. Benennung und Best.-Nr. des gewünschten Teils

Bestell-Beispiel:

Für Kompressoanlage ...  
Fabrik-Nr. 524-0528/1/2 drei Dichtungen  
8263-090

**Important notes for spare parts orders:**

Part nos. beginning with digit 0 indicate parts available as complete assemblies. Parts without part no. are indicated for assembly reference, only. These parts are not available as single parts. When placing an order for spare parts, please give the following items so as to ensure our correct delivery (see identification plate shown below):

1. Model, serial no. as well as design standard of unit/block
2. Quantity required
3. Name and part no.

Example for order:

For compressor unit ...  
serial no. 524-0528/1/2, three gaskets  
8263-090

**Avis important pour la commande de pièces:**

Les nos. de commande commençant par le chiffre 0 indiquent les pièces livrées au complet. Les pièces sans no. de commande sont indiquées uniquement pour information de montage. Elles ne sont pas livrées individuellement. Pour que la livraison de pièces de rechange corresponde à la commande, veuillez bien nous fournir les données suivantes (voir plaque d'identité ci-dessous):

1. Modèle, no. de série et standard de construction de bloc compresseur/groupe
2. Quantité désirée
3. Dénomination et no. de commande de la pièce désirée

Exemple de commande:

Pour groupe compresseur ...  
no. de série 524-0528/1/2, trois joints no. de cde. 8263-090



**Wartungssätze**

- a = Wartungssatz 500 h bzw. bei Bedarf
- b = Wartungssatz 1000 h, mind. jährlich
- c = Wartungssatz 2000 h, mind. alle 2 Jahre



**Maintenance kits:**

- a = Maintenance kit 500 h or as required
- b = Maintenance kit 1000 h, at least annually
- c = Maintenance kit 2000 h, at least biennially



**Kits de maintenance :**

- a = Kit d'entretien 500 h ou au besoin
- b = Kit d'entretien 1000 h, au moins un fois par an
- c = Kit d'entretien 2000 h, au moins tous les 2 ans

In den Spalten sind die im entsprechenden Satz enthaltenen Teile angekreuzt. Bitte beachten, daß die höheren Sätze die untergeordneten nicht beinhalten, d.h. für eine 2000-Stunden-Wartung wird 1x Satz a, 1x Satz b und 1x Satz c benötigt.

The columns contain the parts that are included in the respective parts set. Please note that the higher graded kits do not include the lower ones, i.e. for a 2000 hours maintenance, one kit a, one kit b plus one kit c are required.

Les pièces contenues dans les kits correspondants sont marquées d'une croix dans les colonnes. Veuillez observer que les kits supérieurs ne contiennent pas les kits subordonnés, c'est-à-dire pour un entretien de 2000 heures il faut avoir 1x kit a, 1x kit b et 1x kit c.

Anmerkungen zur Identifikation:  
Remarks for identification:  
Remarques pour l'identification:

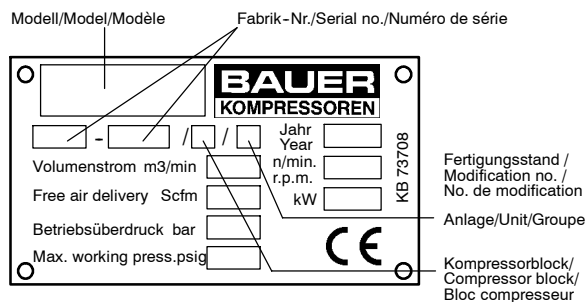

**ACHTUNG**

Nur Schrauben und Stiftschrauben der Qualität 8.8 verwenden!



**ATTENTION**

Use only screws and studs in quality 8.8! This quality is equivalent to SAE J 429 d grade 5.



**ATTENTION**

N'utiliser que des vis et des goujons filetés de la qualité 8.8!

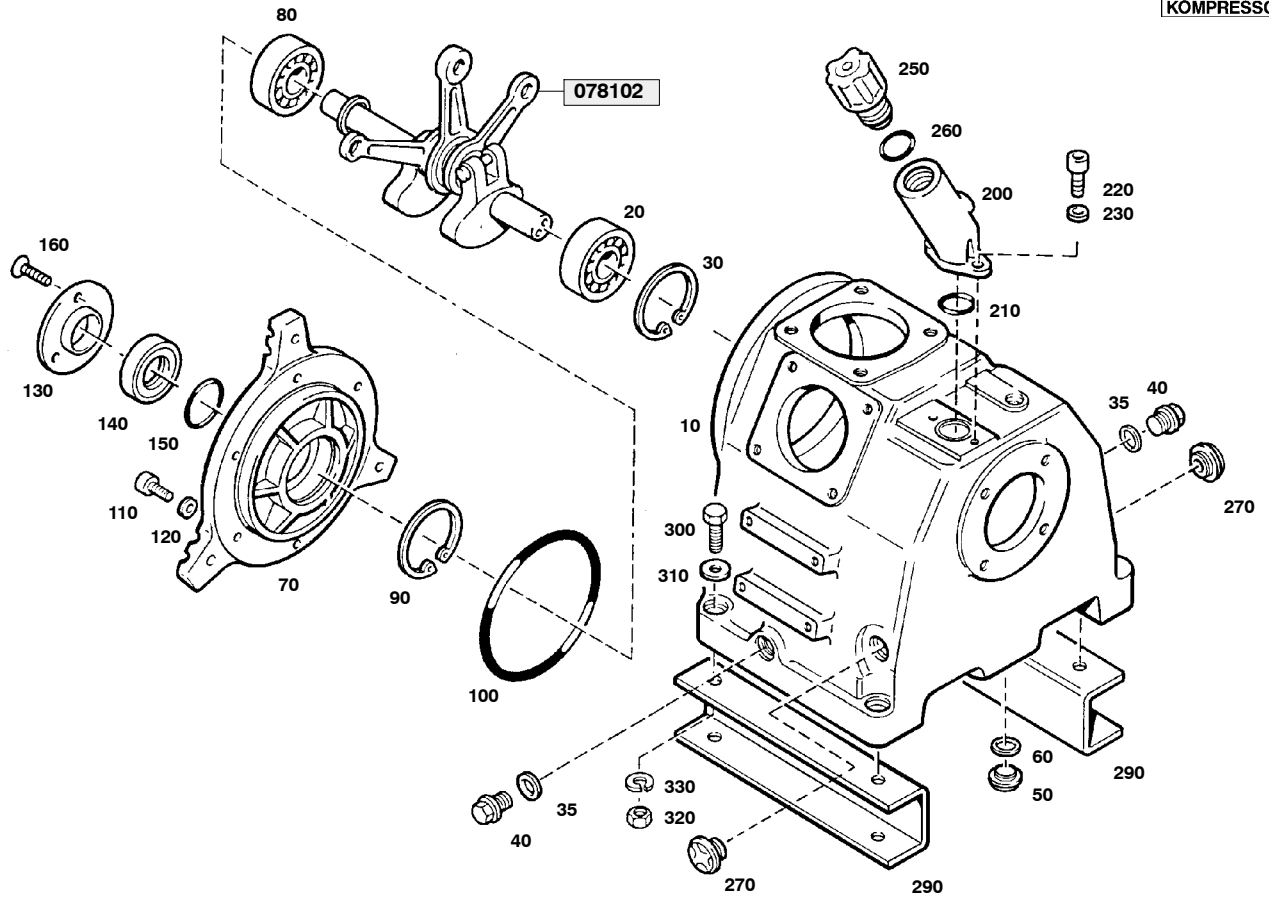
 Wartungssätze  
 Maintenance sets  
 Kits d'entretien

**Baugruppe** 076743  
**Assembly** 076743  
**Assemblage** 076743

**Kurbelgehäuse, m. Zubehör, Triebwerk**  
**Crankcase with accessories, driving gear**  
**Carter avec accessoires, embiellage**
**TM320-1**

Klasse/ Class/ Classe			Pos.	Bestell-Nr. Part No. No. de cde.	Anz. Qty. Qté.	Benennung	Designation	Dénomination
a	b	c						
			10	76740	1	Kurbelgehäuse	crankcase	carter
			20	N2638	1	Zylinderrollenlager	cylindrical roller bearing	roulement à rouleaux
			30	N2635	1	Sicherungsring	circlip ring	rondelle de sûreté
X			35	N4163	2	Dichtring	gasket	joint
			40	N2796	2	Verschlußschraube	plug	bouchon fileté
			50	N4570	1	Verschlußschraube	plug	bouchon fileté
			60	N1316	1	Dichtring	gasket	joint
			70	66209	1	Lagerdeckel	bearing cap	couvercle de palier
			80	N15406	1	Zylinderrollenlager	cylindrical roller bearing	roulement à rouleaux
			90	N2635	1	Sicherungsring	circlip ring	rondelle de sûreté
			100	N15265	1	O-Ring	o-ring	joint torique
			110	N756	6	Sechskantschraube	hexagon screw	vis hexagonale
			120	N58	6	Scheibe	washer	rondelle
			130	66684	1	Deckel	cover	couvercle
			140	N170	1	Wellendichtring	shaft seal	bague d'étanchéité
			150	N3745	1	O-Ring	o-ring	joint torique
			160	N16128	3	Senkschraube	countersunk screw	vis à tête fraisée
			200	73830	1	Öleinfüllstutzen	oil filling pipe	tubulure de remplissage
			210	N4776	1	O-Ring	o-ring	joint torique
			220	N88	2	Sechskantschraube	hexagon screw	vis hexagonale
			230	N58	2	Scheibe	washer	rondelle
			250	61054	1	Verschlußschraube	plug	bouchon fileté
			260	N15412	1	O-Ring	o-ring	joint torique
			270	N25475	2	Ölstandsauge	oil sight gauge	regard d'huile
			290	78038	2	Kompressorfuß	support	ped de compresseur
			300	N350	4	Sechskantschraube	hexagon screw	vis hexagonale
			310	N16	4	Scheibe	washer	rondelle

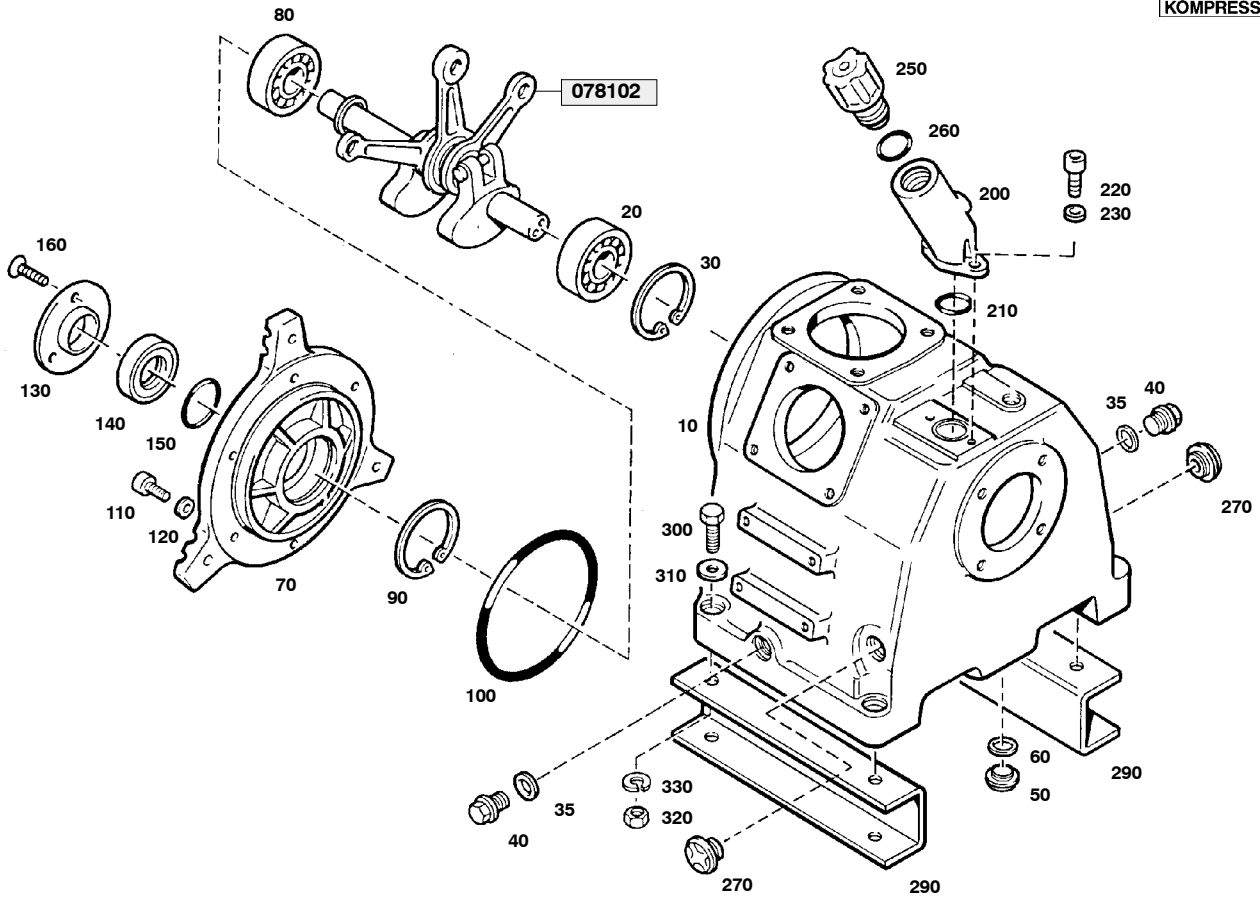

Wartungssätze  
Maintenance sets  
Kits d'entretien

Baugruppe 076743 Kurbelgehäuse, m. Zubehör, Triebwerk  
 Assembly 076743 Crankcase with accessories, driving gear  
 Assemblage 076743 Carter avec accessoires, embiellage

**TM320-1**

Klasse/ Class/ Classe			Pos.	Bestell-Nr. Part No. No. de cde.	Anz. Qty. Qté.	Benennung	Designation	Dénomination
a	b	c						
			320	N176	4	Federring	spring washer	rondelle-ressort
			330	N177	4	Sechskantmutter	hexagon nut	écrou hexagonal

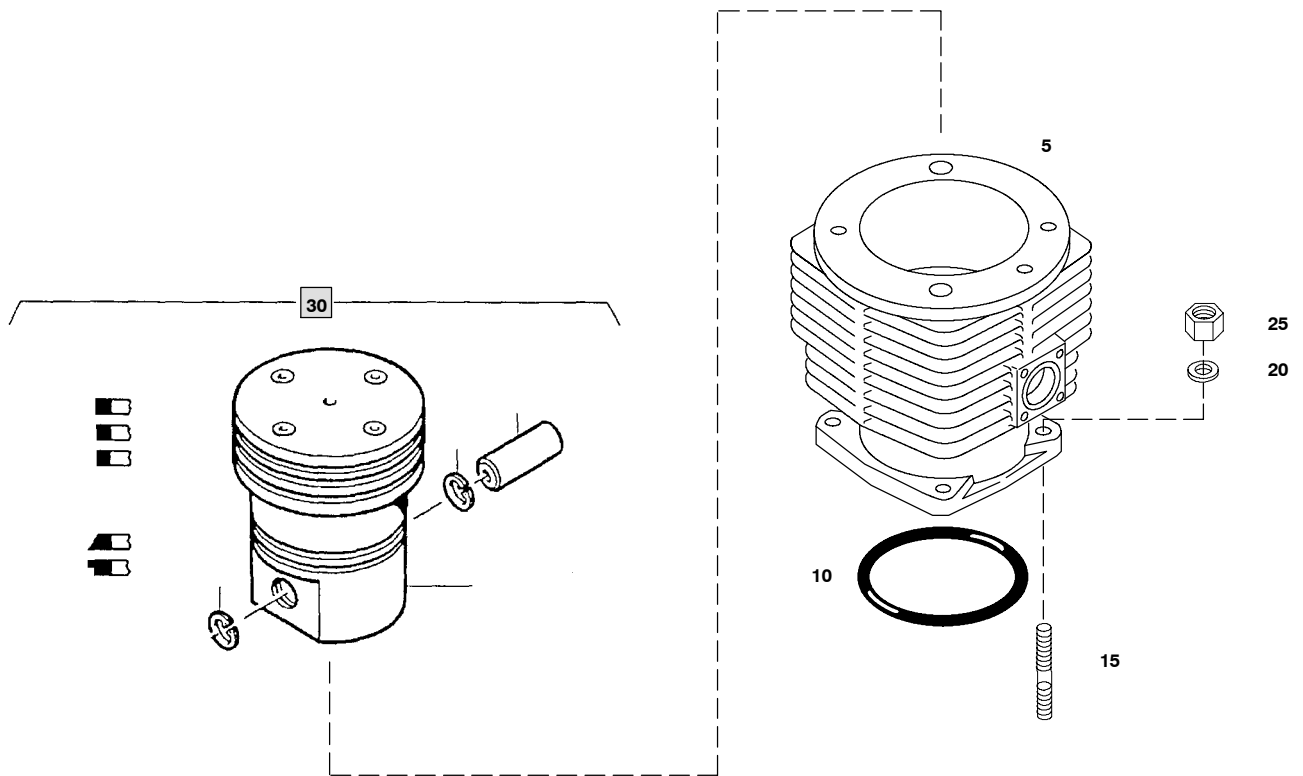
 Ersatzteilsätze  
 Spare parts sets  
 Kits de pièces dét.

**Baugruppe** 80825  
**Assembly** 80825  
**Assemblage** 80825

**Zylinder 1./2. Stufe**  
**Cylinder 1st/2nd stage**  
**Cylindre 1er/2e étage**
**TM320-2**

Klasse/ Class/ Classe			Pos.	Bestell-Nr. Part No. No. de cde.	Anz. Qty. Qté.	Benennung	Designation	Dénomination
a	b	c						
			5	80729	1	Stufenzylinder	stepped cylinder	cylindre étagé
		X	10	N4654	1	O-Ring	o-ring	joint torique
			15	N215	4	Stiftschraube	stud	goujon fileté
			20	N58	4	Scheibe	washer	rondelle
		X	25	N370	4	Selbstsichernde Mutter	hexagon nut self-locking	écrou hexagonal auto-frein.
			30	78095	1	Kolben kpl.	piston cpl.	piston cpl.

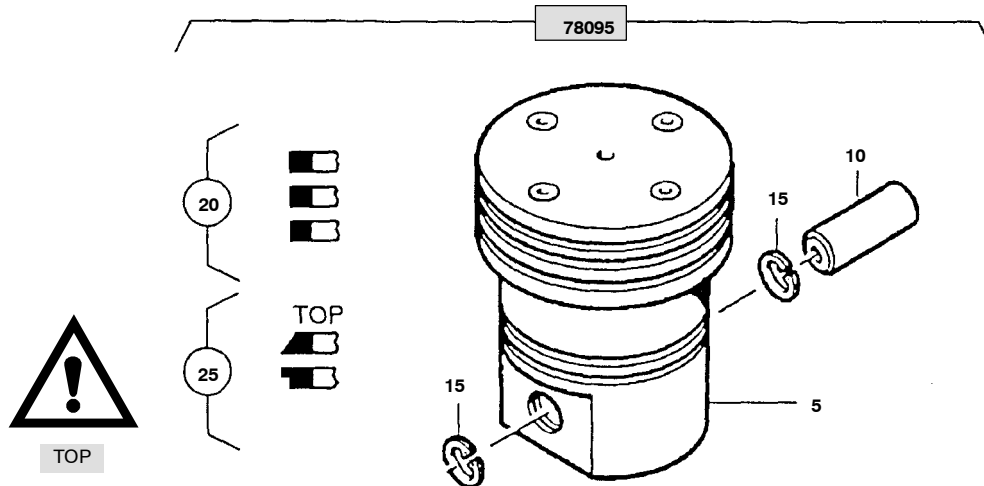

 Ersatzteilsätze  
 Spare parts sets  
 Kits de pièces dét.

**Baugruppe** 78095  
**Assembly** 78095  
**Assemblage** 78095

**Stufenkolben kpl.**  
**Stepped piston cpl.**  
**Piston étagé cpl.**
**TM320-2a**

Klasse/ Class/ Classe			Pos.	Bestell-Nr. Part No. No. de cde.	Anz. Qty. Qté.	Benennung	Designation	Dénomination
a	b	c						
			5	78097	1	Stufenkolben	stepped piston	piston étagé
			10	N1216	1	Kolbenbolzen	piston pin	coussinet
			15	N484	2	Sicherungsring	circlip ring	rondelle de sûreté
			20	N25842	1	Kolbenringsatz	piston ring set	jeu des segments de piston
			25	N25396	1	Kolbenringsatz	piston ring set	jeu des segments de piston

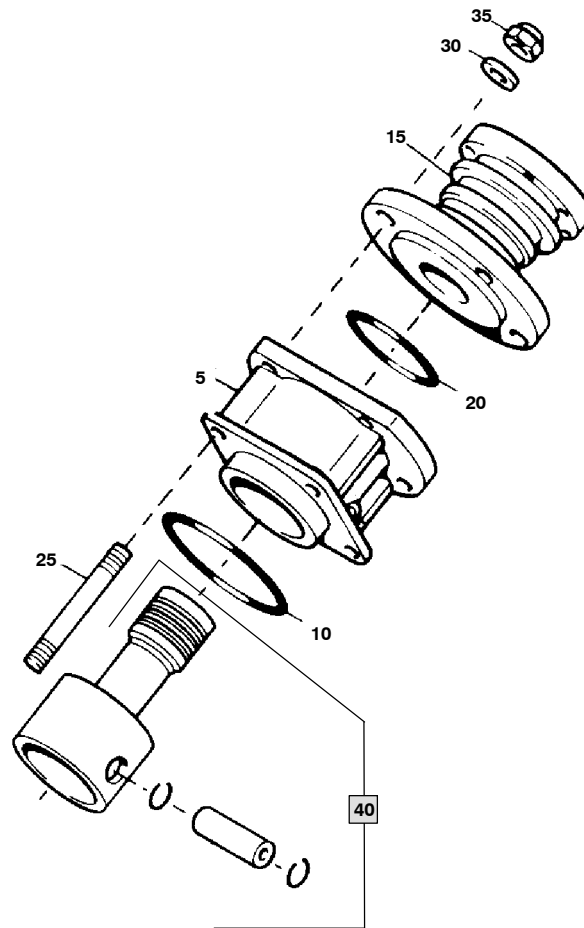

 Ersatzteilsätze  
 Spare parts sets  
 Kits de pièces dét.

**Baugruppe** 78335 **Zylinder 3. Stufe**  
**Assembly** 78335 **Cylinder 3rd stage**  
**Assemblage** 78335 **Cylindre 3e étage**
**TM320-3**

Klasse/ Class/ Classe			Pos.	Bestell-Nr. Part No. No. de cde.	Anz. Qty. Qté.	Benennung	Designation	Dénomination
a	b	c						
			5	66622	1	Führungszylinder	guide cylinder	cylindre de guidage
		X	10	N2640	1	O-Ring	o-ring	joint torique
			15	67940	1	Zylinder	cylinder	cylindre
		X	20	N7063	1	O-Ring	o-ring	joint torique
			25	N2790	4	Stiftschraube	stud	goujon fileté
			30	N58	4	Scheibe	washer	rondelle
		X	35	N370	4	Sechskantmutter	hexagon nut self-locking	écrou hexagonal auto-frein.
			40	78334	1	Kolben kpl.	piston cpl.	piston cpl.

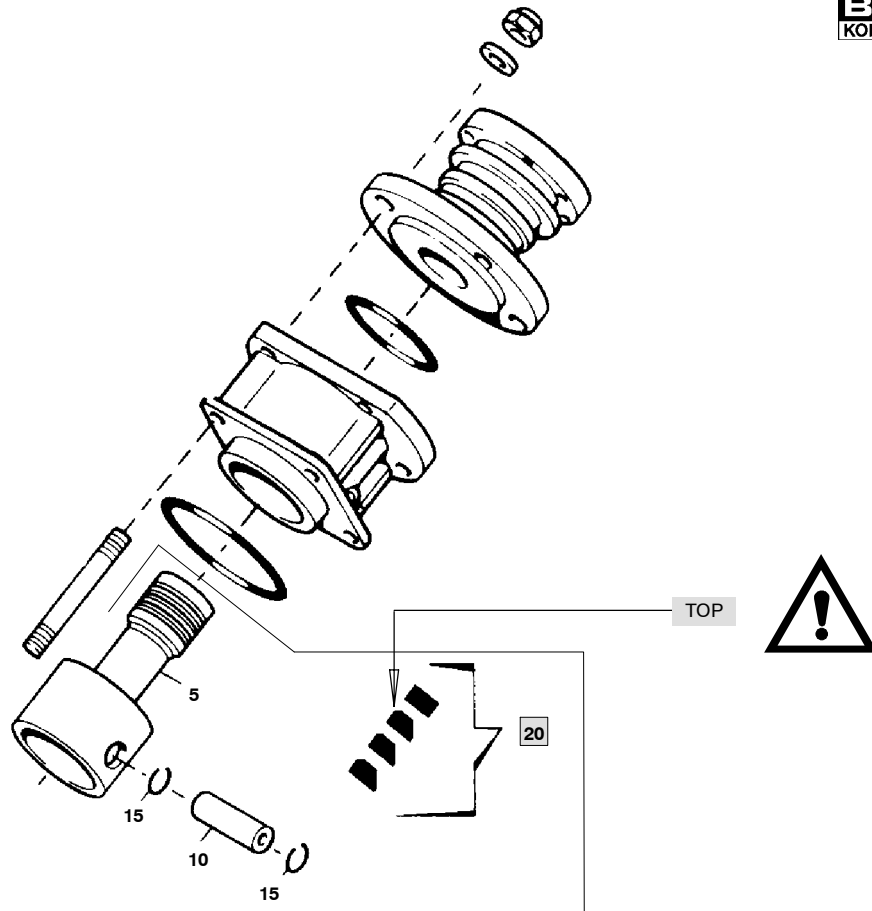

Ersatzteilsätze  
Spare parts sets  
Kits de pièces dét.

Baugruppe 78334 Kolben kpl.  
Assembly 78334 Piston cpl.  
Assemblage 78334 Piston cpl.

**TM320-3a**

Klasse/ Class/ Classe			Pos.	Bestell-Nr. Part No. No. de cde.	Anz. Qty. Qté.	Benennung	Designation	Dénomination
0	2	5						
			5	67942	1	Kolben	piston	piston
			10	N1429	1	Kolbenbolzen	piston pin	coussinet
			15	N484	2	Sicherungsring	circlip ring	rondelle de sûreté
			20	N19833	1	Kolbenringsatz	piston ring set	jeu de segments de piston

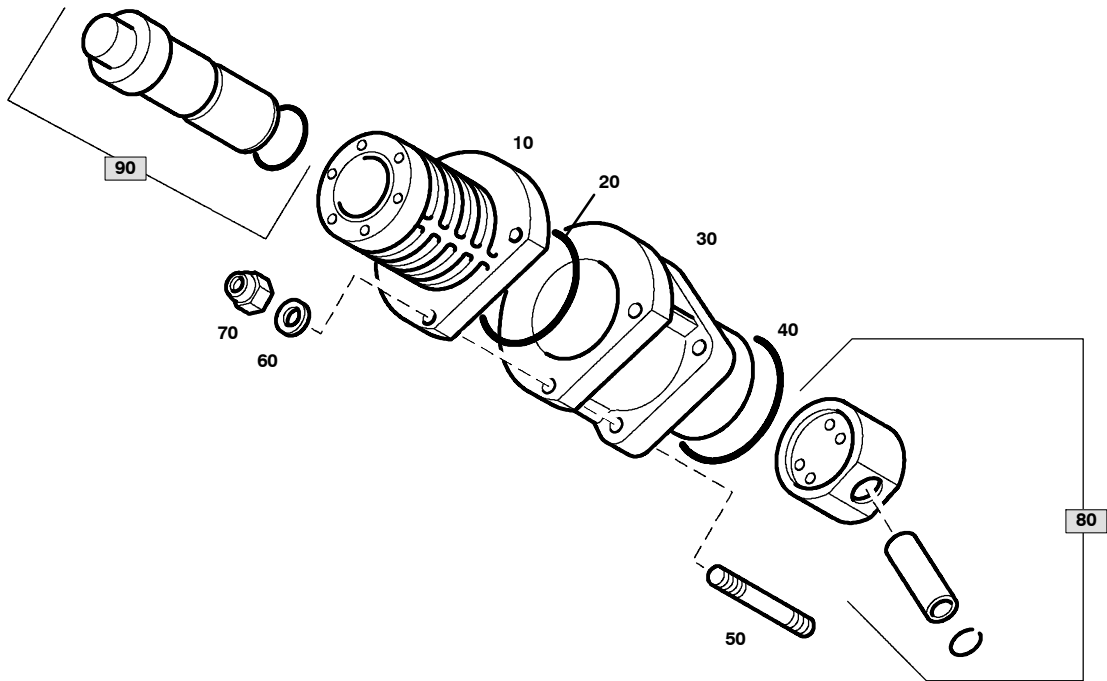
 Ersatzteilsätze  
 Spare parts sets  
 Kits de pièces dét.

<b>Baugruppe</b>	<b>078044</b>	<b>Zylinder</b>
<b>Assembly</b>	<b>078044</b>	<b>Cylinder</b>
<b>Assemblage</b>	<b>078044</b>	<b>Cylindre</b>

**TM320-4**

Klasse/ Class/ Classe			Pos.	Bestell-Nr. Part No. No. de cde.	Anz. Qty. Qté.	Benennung	Designation	Dénomination
a	b	c						
			10	76754	1	Zylinder	cylinder	cylindre
		X	20	N7063	1	O-Ring	o-ring	joint torique
			30	80381	1	Führungszylinder	guide cylinder	cylindre de guidage
		X	40	N2640	1	O-Ring	o-ring	joint torique
			50	N2790	4	Stiftschraube	stud	goujon fileté
			60	N58	4	Scheibe	washer	rondelle
		X	70	N370	4	Sechskantmutter	hexagon nut self-locking	écrou hexagonal auto-frein.
			80	072165	1	Kolben kpl.	piston cpl.	piston cpl.
			90	078045	1	Kolbenbüchse kpl.	sleeve	douille

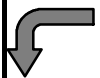
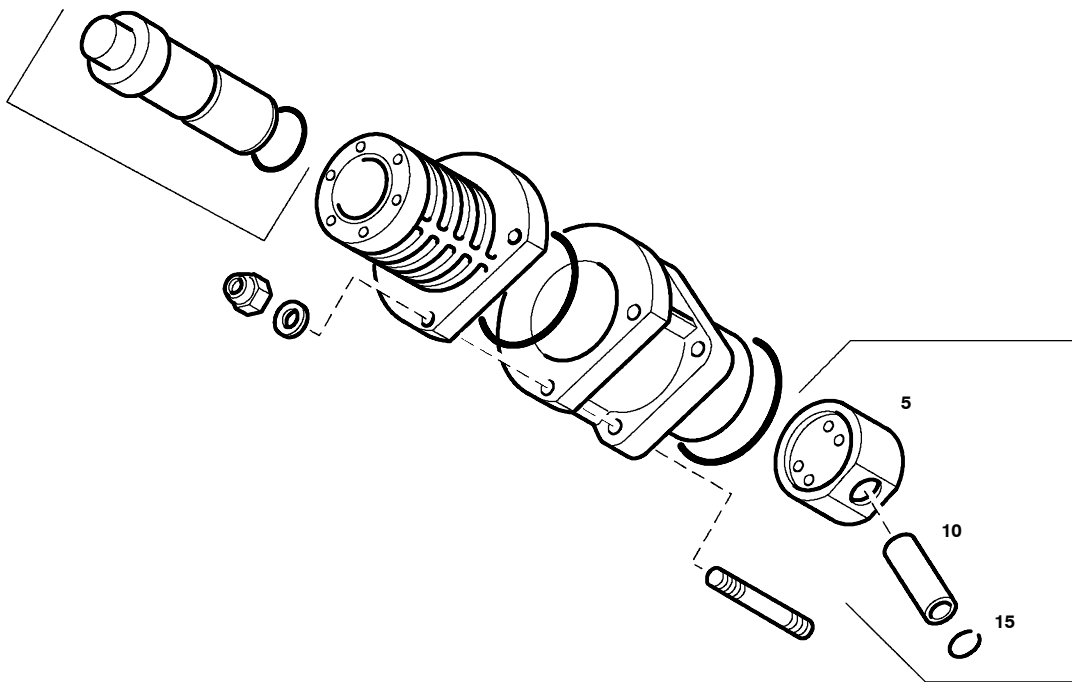

Ersatzteilsätze  
Spare parts sets  
Kits de pièces dét.

Baugruppe 072165 Kolben kpl.  
Assembly 072165 Piston assy.  
Assemblage 072165 Piston cpl.

**TM320-4a**

Klasse/ Class/ Classe			Pos.	Bestell-Nr. Part No. No. de cde.	Anz. Qty. Qté.	Benennung	Designation	Dénomination
0	2	5						
			5	N858	1	Führungskolben	guide piston	piston guide
			10	N1429	1	Kolbenbolzen	piston pin	coussinet
			15	N484	2	Sicherungsring	circlip ring	rondelle de sûreté

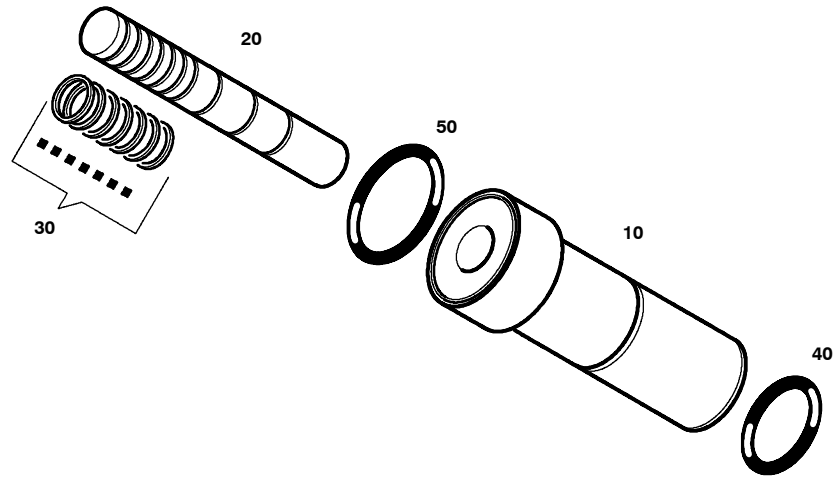

 Ersatzteilsätze  
 Spare parts sets  
 Kits de pièces dét.

**Baugruppe** 078045 **Kolbenbüchse kpl.**  
**Assembly** 078045 **Piston and sleeve**  
**Assemblage** 078045 **Douille de piston**
**TM320-4b**

Klasse/ Class/ Classe			Pos.	Bestell-Nr. Part No. No. de cde.	Anz. Qty. Qté.	Benennung	Designation	Dénomination
a	b	c						
			10	*	1	Kolbenbüchse	piston liner	douille de piston
			20	*	1	Kolben	piston	piston
			30	*	1	Kolbenringsatz	piston ring set	jeu des segments
		X	40	N2320	1	O-Ring	o-ring	joint torique
X			50	N23755	1	O-Ring	o-ring	joint torique

**IK12.14 II**  
**IK120 II**

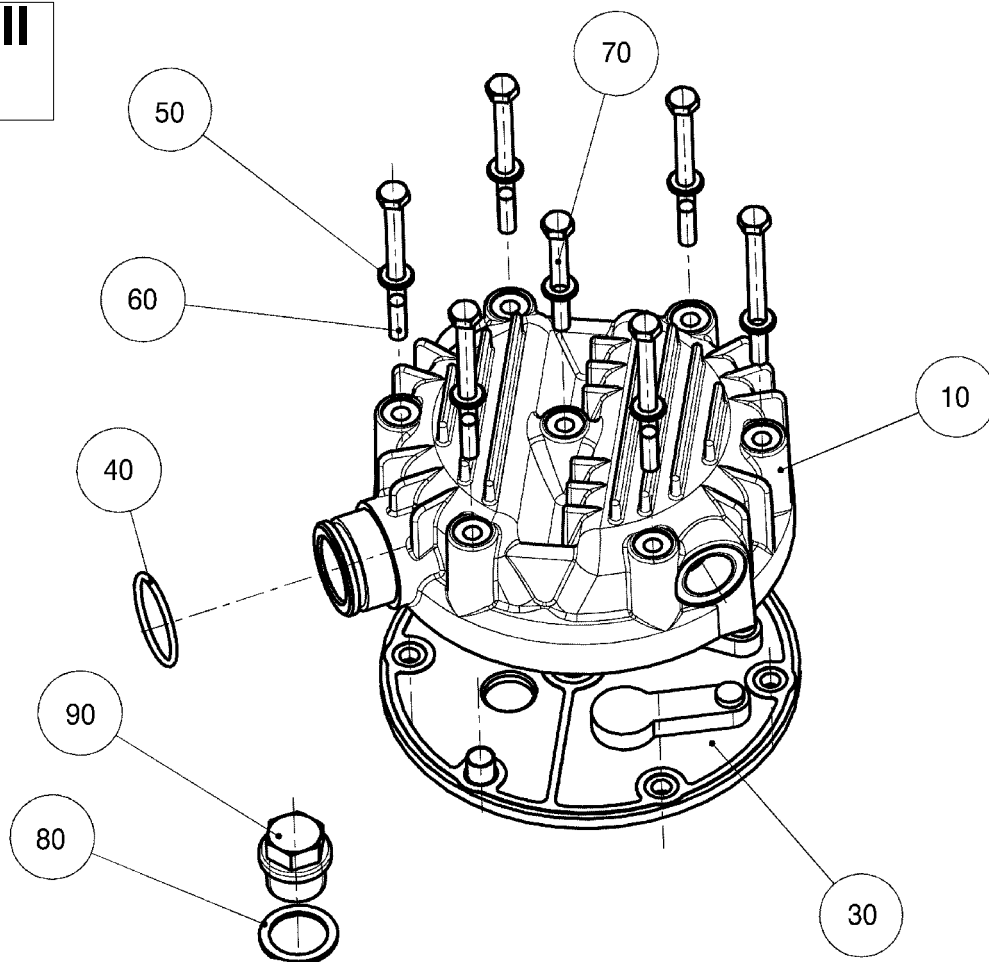
**BAUER**  
KOMPRESSOREN



Wartungssätze  
Maintenance sets  
Kits d'entretien

Baugruppe **80688**  
Assembly **80688**  
Assemblage **80688**

Ventilkopf 1. Stufe  
Valve head 1st stage  
Culasse 1er étage

**TM320-5**

Klasse/ Class/ Classe			Pos.	Bestell-Nr. Part No. No. de cde.	Anz. Qty. Qté.	Benennung	Designation	Dénomination
a	b	c						
			5	80677	1	Ventilkopf	valve head	culasse
			30	N26531	1	Lamellenventil	reed valve	soupape à lamelles
			40	N1539	1	O-Ring	o-ring	joint torique
			50	N102	1	Scheibe	washer	rondelle
			60	N26568	6	Sechskantschraube	hex. screw	vis six pans
			70	N26646	1	Sechskantschraube	hex. screw	vis six pans
			80	N293	1	Dichtring	gasket	joint
			90	N314	1	Verschlußschraube	plug	bouchon

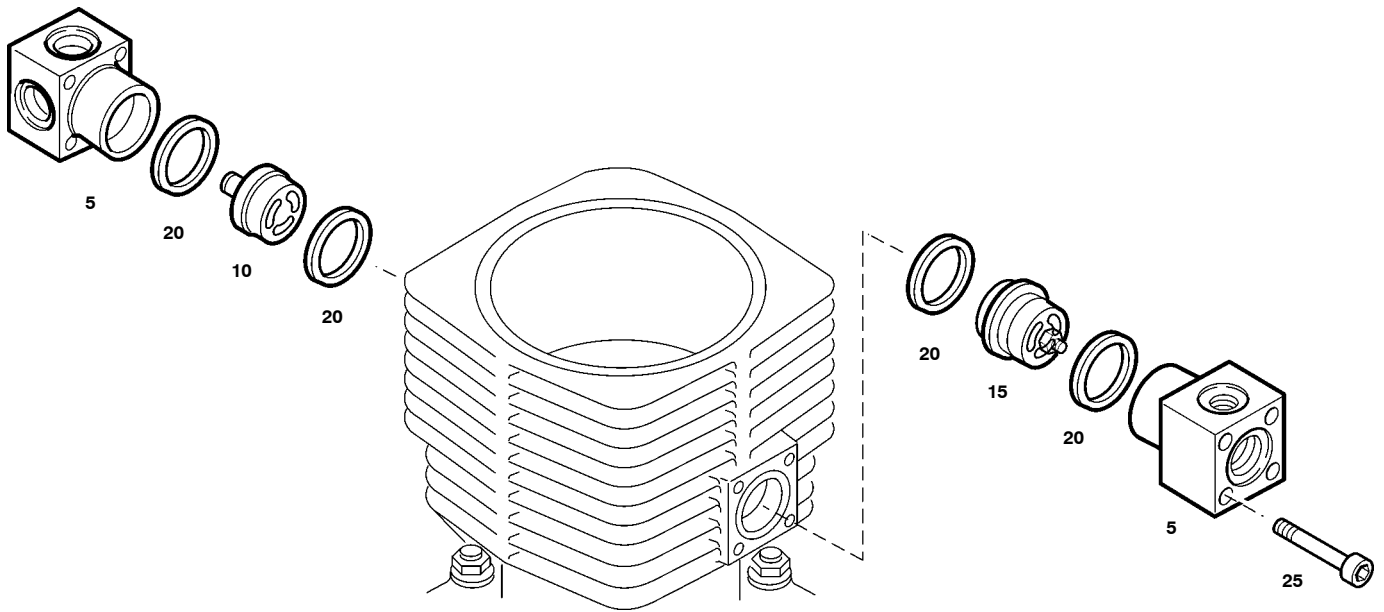
 Ersatzteilsätze  
 Spare parts sets  
 Kits de pièces dét.

**Baugruppe** 073435  
**Assembly** 073435  
**Assemblage** 073435

**Ventilkopf 2. Stufe**  
**Valve head 2nd stage**  
**Culasse 2e étage**
**TM320-6**

Klasse/ Class/ Classe			Pos.	Bestell-Nr. Part No. No. de cde.	Anz. Qty. Qté.	Benennung	Designation	Dénomination
a	b	c						
			5	78562	2	Saug- und Druckstutzen	intake and pressure coupling	raccord d'aspiration et de compression
	X		10	N4067	1	Saugventil kpl.	intake valve	soupape d'aspiration
	X		15	N4068	1	Druckventil kpl.	pressure valve	soupape de compression
X			20	56668	4	Dichtring	gasket	joint
			25	N724	8	Zylinderschraube	allen screw	vis à six pans creux

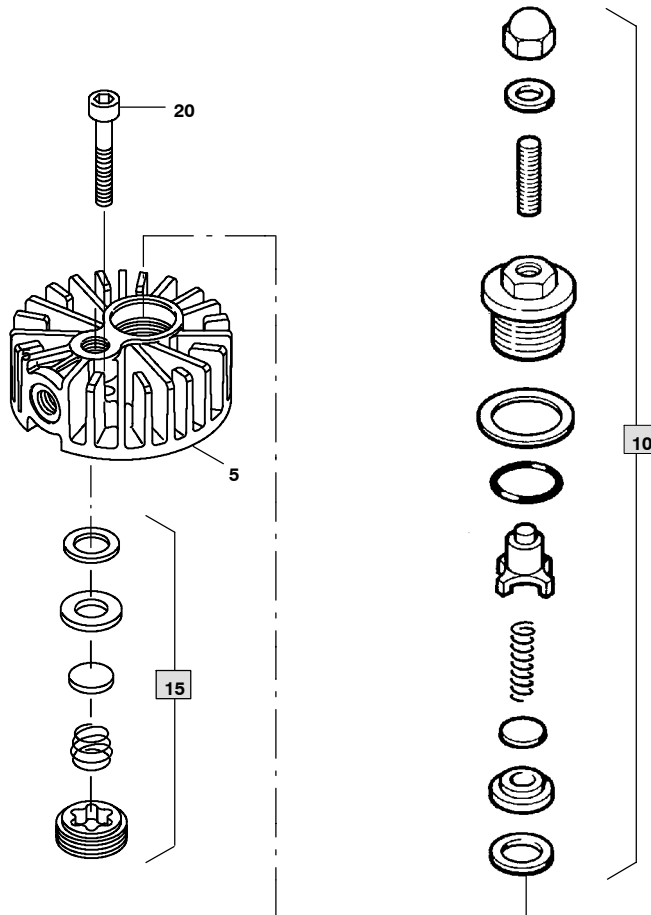

Ersatzteilsätze  
Spare parts sets  
Kits de pièces dét.

**Baugruppe** 069792 **Ventilkopf 3. Stufe**  
**Assembly** 069792 **Valve head 3rd stage**  
**Assemblage** 069792 **Culasse 3e étage**

**TM320-7**

Klasse/ Class/ Classe			Pos.	Bestell-Nr. Part No. No. de cde.	Anz. Qty. Qté.	Benennung	Designation	Dénomination
a	b	c						
			5	14123	1	Ventilkopf	valve head	culasse
			10	014582	1	Druckventil kpl.	pressure valve	soupape de compression
	X		15	012836	1	Saugventil	suction valve	soupape d'aspiration
			20	N503	6	Zylinderschraube	allen screw	vis à six pans creux



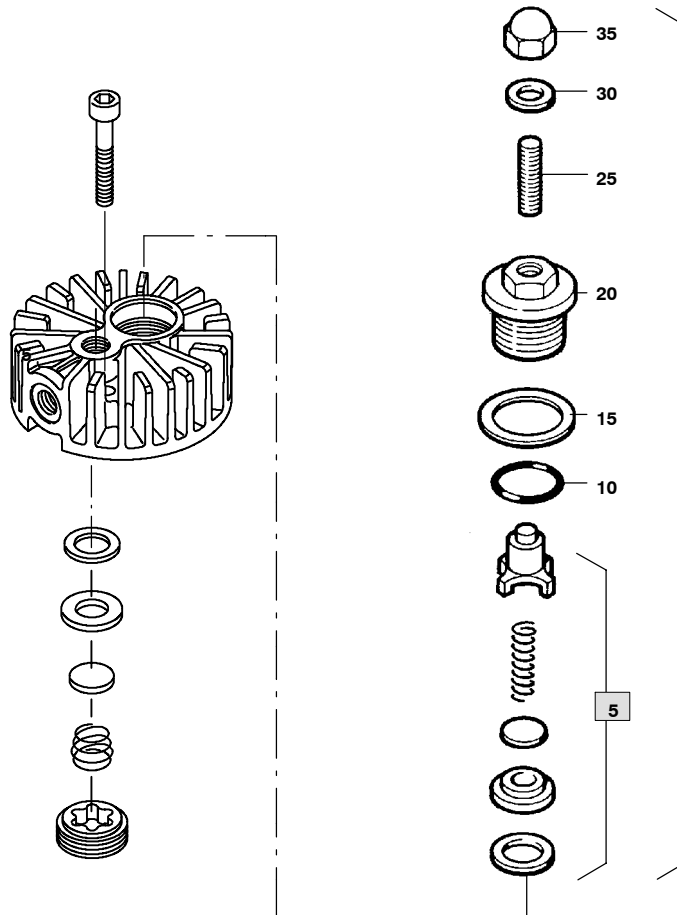

 Ersatzteilsätze  
 Spare parts sets  
 Kits de pièces dét.

<b>Baugruppe</b>	<b>014582</b>	<b>Druckventil kpl.</b>
<b>Assembly</b>	<b>014582</b>	<b>Pressure valve</b>
<b>Assemblage</b>	<b>014582</b>	<b>Soupape de compression</b>

**TM320-7a**

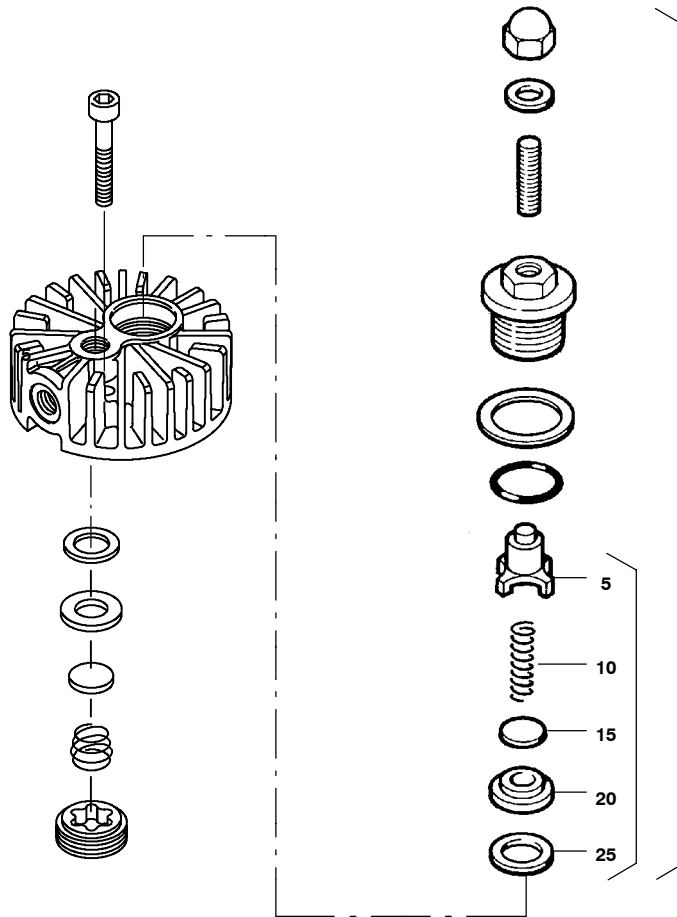
Klasse/ Class/ Classe			Pos.	Bestell-Nr. Part No. No. de cde.	Anz. Qty. Qté.	Benennung	Designation	Dénomination
a	b	c						
	X		5	012835	1	Druckventileinsatz kpl.	pressure valve insert	soupape de compression
X			10	N3521	1	O-Ring	o-ring	joint torique
			15	14332	1	Tellerfeder	spring washer	rondelle-ressort
			20	14124	1	Verschraubung	coupling	raccord
	X		25	71064	1	Gewindestift	stud	goujon fileté
X			30	N380	1	Dichtung	gasket	joint
			35	N84	1	Sechskant-Hutmutter	acorn nut	écrou borgne

 Ersatzteilsätze  
 Spare parts sets  
 Kits de pièces dét.

**Baugruppe** 012835  
**Assembly** 012835  
**Assemblage** 012835

**Druckventileinsatz kpl.**  
**Pressure valve insert**  
**Soupape de compression**
**TM320-7b**

Klasse/ Class/ Classe			Pos.	Bestell-Nr. Part No. No. de cde.	Anz. Qty. Qté.	Benennung	Designation	Dénomination
a	b	c						
			5		1	Druckventileinsatz	pressure valve insert	soupape de compression
			10	1026	1	Ventilfeder	valve spring	ressort de soupape
			15		1	Ventilplatte	valve plate	plaque de soupape
			20		1	Ventilsitz	valve seat	siège de soupape
X			25	240	1	Dichtung	gasket	joint

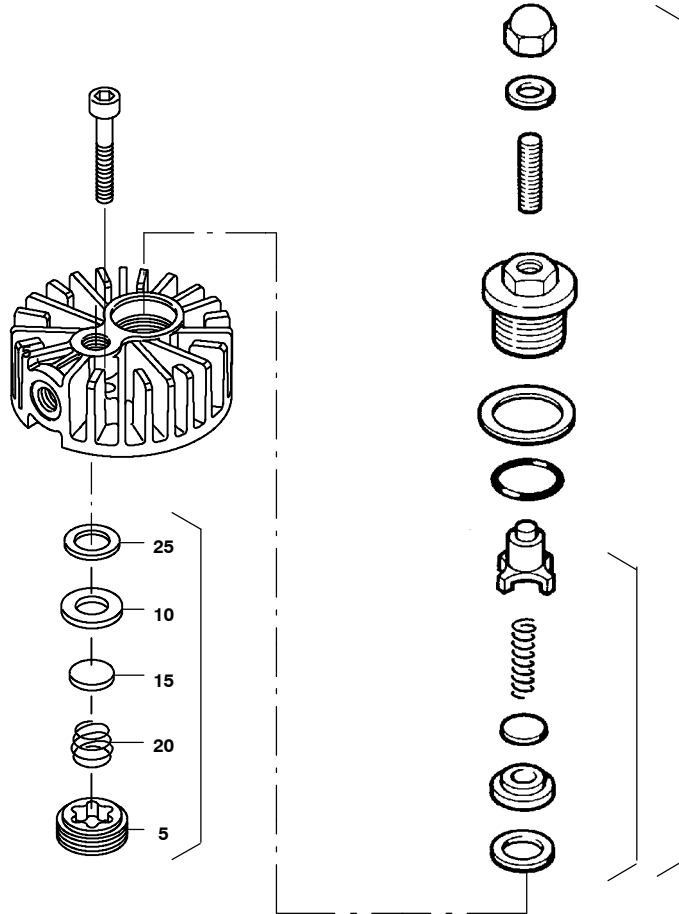

Ersatzteilsätze  
Spare parts sets  
Kits de pièces dét.

**Baugruppe** 012836  
**Assembly** 012836  
**Assemblage** 012836

**Saugventil**  
**Suction valve**  
**Soupape d'aspiration**

**TM320-7c**

Klasse/ Class/ Classe			Pos.	Bestell-Nr. Part No. No. de cde.	Anz. Qty. Qté.	Benennung	Designation	Dénomination
a	b	c						
			5		1	Ventilverschraubung	valve screwing	filetage de soupape
			10		1	Ventilsitz	valve seat	siège de soupape
			15		1	Ventilplatte	valve plate	plaque de soupape
			20		1	Druckfeder	pressure spring	ressort de pression
X			25	240	1	Dichtung	gasket	joint

**BK12.2 II**  
**BK15.3 II**  
**BK15.4 II**  
**IK12.4 II**  
**IK12.14 II**  
**IK100 II**  
**IK120 II**

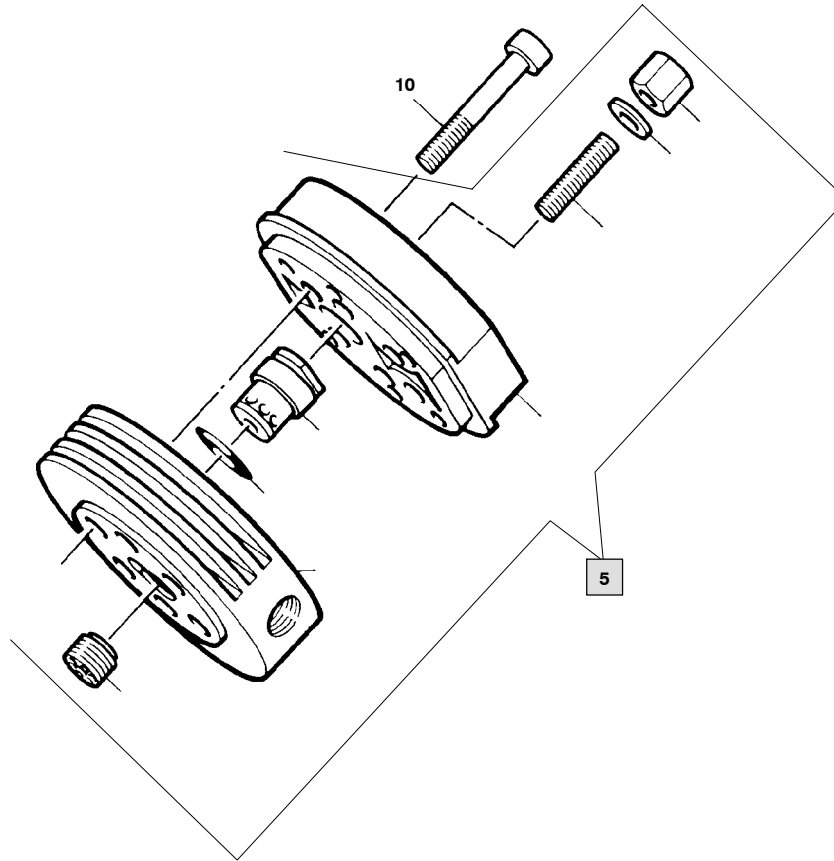

068607/12/948



Wartungssätze  
 Maintenance sets  
 Kits d'entretien

**Baugruppe** 068607 **Ventilkopf**  
**Assembly** 068607 **Valve head**  
**Assemblage** 068607 **Culasse**

**TM320-8**

Klasse/ Class/ Classe			Pos.	Bestell-Nr. Part No. No. de cde.	Anz/ Qty/ Qté	Benennung	Designation	Dénomination
a	b	c						
			5	073629	1	Ventilkopf	valve head	culasse
			10	N1282	6	Zylinderschraube	allen screw	vis à six pans creux

**BK12.2 II**  
**BK15.3 II**  
**BK15.4 II**  
**IK12.4 II**  
**IK12.14 II**  
**IK100 II**  
**IK120 II**

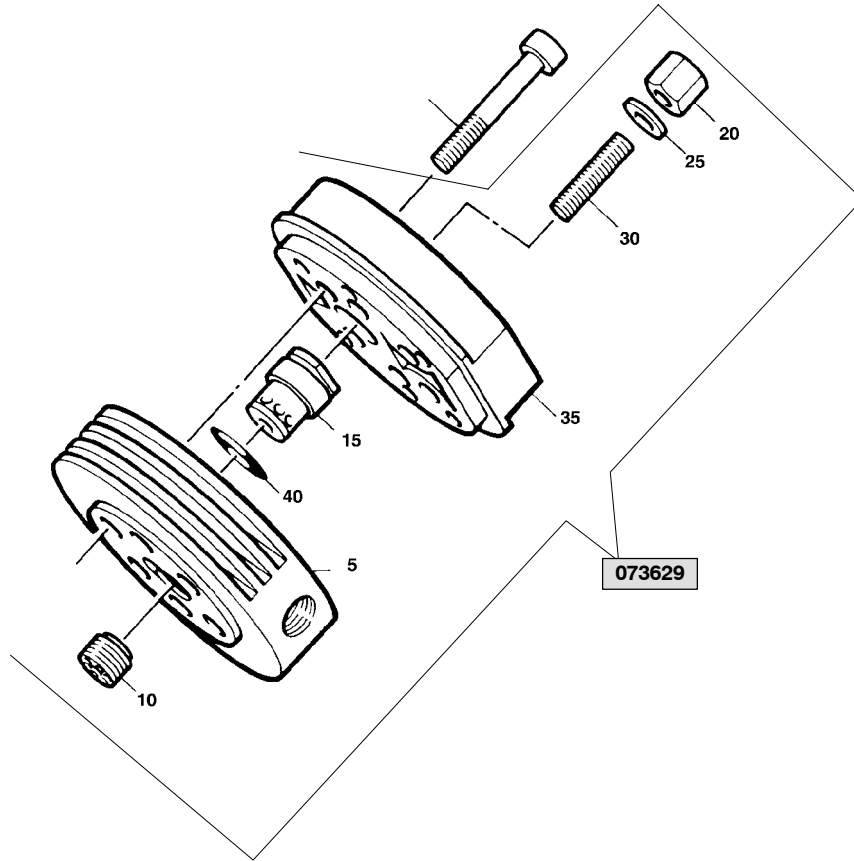

073629/12/98



Wartungssätze  
 Maintenance sets  
 Kits d'entretien

**Baugruppe** 073629  
**Assembly** 073629  
**Assemblage** 073629

**Ventilkopf**  
**Valve head**  
**Culasse**

**TM320-8a**

Klasse/ Class/ Classe			Pos.	Bestell-Nr. Part No. No. de cde.	Anz/ Qty/ Qté	Benennung	Designation	Dénomination
a	b	c						
			5	65191	1	Ventilkopf	valve head	culasse
	X		10	81409	1	Saugventil	suction valve	clapet d'aspiration
	X		15	014121	1	Druckventil	pressure valve	soupape de pression
			20	N3623	1	Sechskant-Hutmutter	acorn nut	écrou borgne
X			25	N3625	1	Dichtring	gasket	joint
	X		30	71065	1	Gewindestift	stud	goujon fileté
			35	14118	1	Ventilkopf-Deckel	valve head cover	couvercle de culasse
			40	N2789	1	O-Ring	o-ring	joint torique

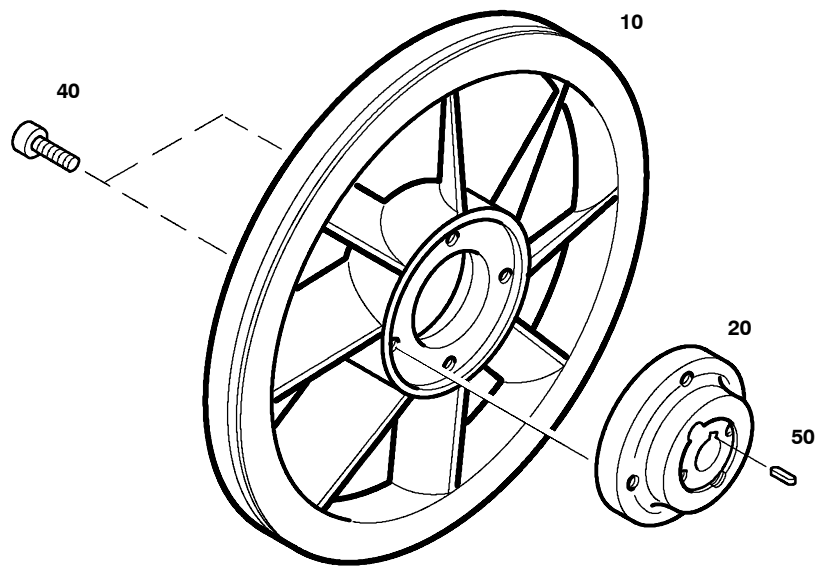
 Wartungssätze  
 Maintenance sets  
 Kits d'entretien

**Baugruppe** 076251 **Schwungrad**  
**Assembly** 076251 **Flywheel**  
**Assemblage** 076251 **Volant-ventilateur**
**TM320-9**

Klasse/ Class/ Classe			Pos.	Bestell-Nr. Part No. No. de cde.	Anz. Qty. Qté.	Benennung	Designation	Dénomination
a	b	c						
			10	76217	1	Ventilatorrad	fanwheel	ventilateur
			20	76211	1	Ventilatorradnabe	fanwheel hub	moyeu de ventilateur
			40	N61	4	Zylinderschraube	allen screw	vis à six pans creux
			50	N1386	1	Paßfeder	feather key	ressort d'ajustage

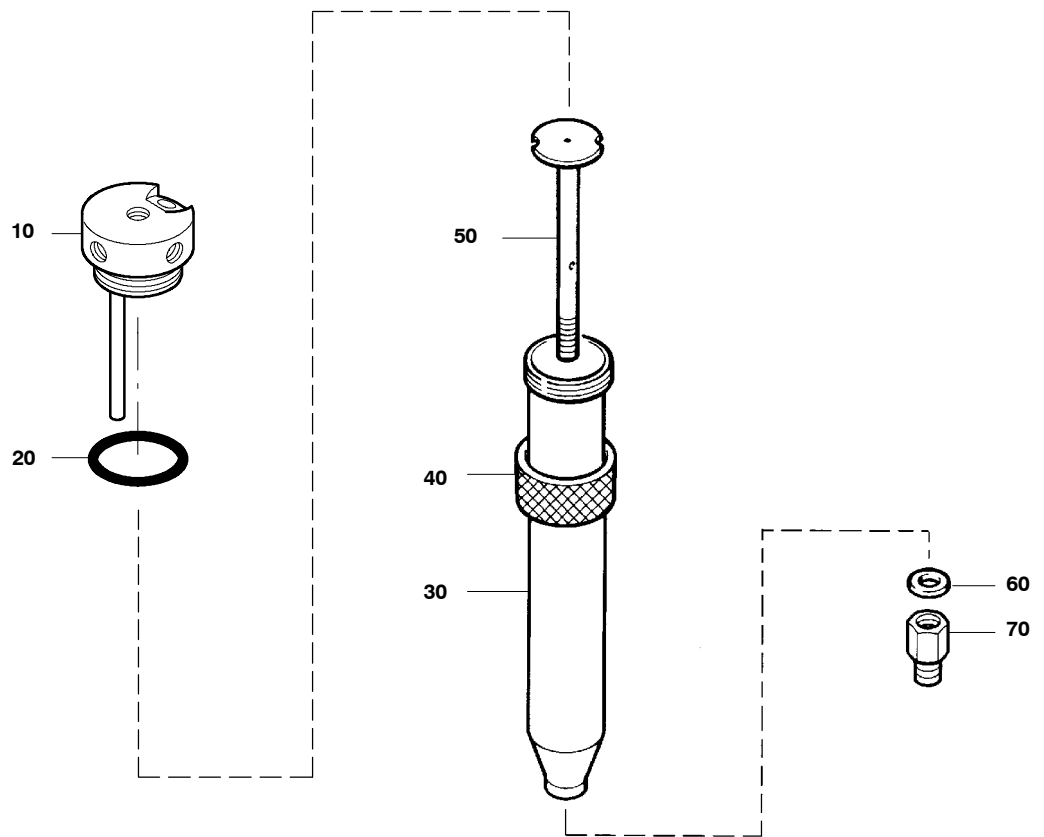

80690/07/02

 Wartungssätze  
 Maintenance sets  
 Kits de maintenance

**Baugruppe** 80690  
**Assembly** 80690  
**Assemblage** 80690

**Zwischenabscheider**  
**Intermediate separator**  
**Séparateur intermédiaire**
**TM320-10**

Klasse/ Class/ Classe			Pos.	Bestell-Nr. Part No. No. de cde.	Anz. Qty. Qté.	Benennung	Designation	Dénomination
a	b	c						
			10	80691*	1	Filterkopf kpl.	filter head assy.	Culasse
X			20	N3556	1	O-Ring	o-ring	joint torique
			30	14150*	1	Behältergehäuse	filter housing	corps de filtre
			40	13937	1	Überwurfmutter	screw cap	écrou borgne
			50	76613	1	Einschraubteil kpl.	screw in part assy.	manchon visse
			60	N1316	1	Dichtring	gasket	joint
			70	N20215	1	G-Aufschraubstutzen	straight connector	raccord droit mâle

\*

nur zusammen lieferbar

only available together

Ne sont livrées qu'ensemble

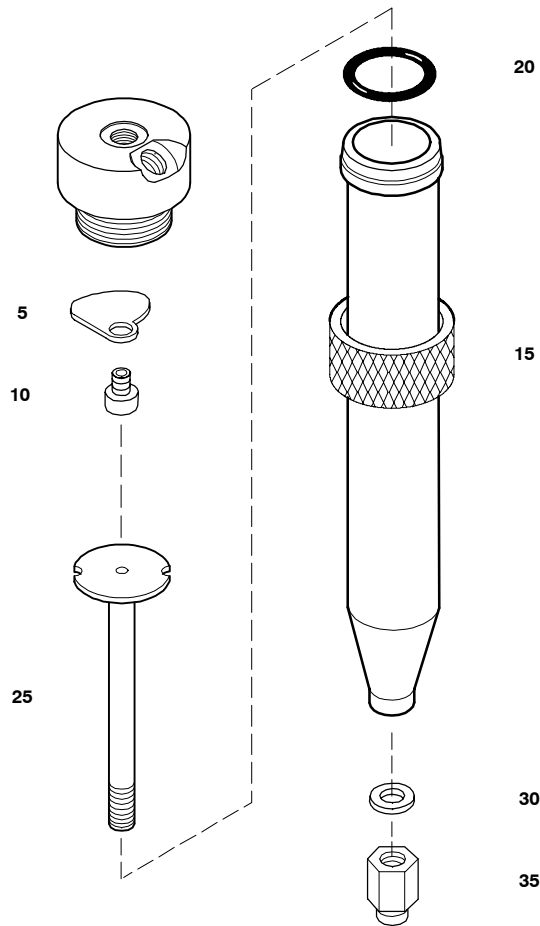

 Wartungssätze  
 Maintenance sets  
 Kits d'entretien

**Baugruppe** 81799  
**Assembly** 81799  
**Assemblage** 81799

**Zwischenfilter**  
**Inter filter**  
**Filtre intermédiaire**
**TM320-11**

Klasse/ Class/ Classe			Pos.	Bestell-Nr. Part No. No. de cde.	Anz/ Qty/ Qté	Benennung	Designation	Dénomination
a	b	c						
			5	81148	1	Blech	plate	plaque
			10	81643	1	Hohlschraube	hollow screw	vis creuse
			15	13937	1	Überwurfmutter	screw cap	écrou borgne
X			20	N3556	1	O-Ring	o-ring	joint torique
			25	76613	1	Einschraubteil kpl.	insert assy.	pièce à visser cpl.
			30	N1316	1	Dichtung	gasket	joint
			35	N20215	1	Ger. Aufschraubst.	male fitting	manchon mâle

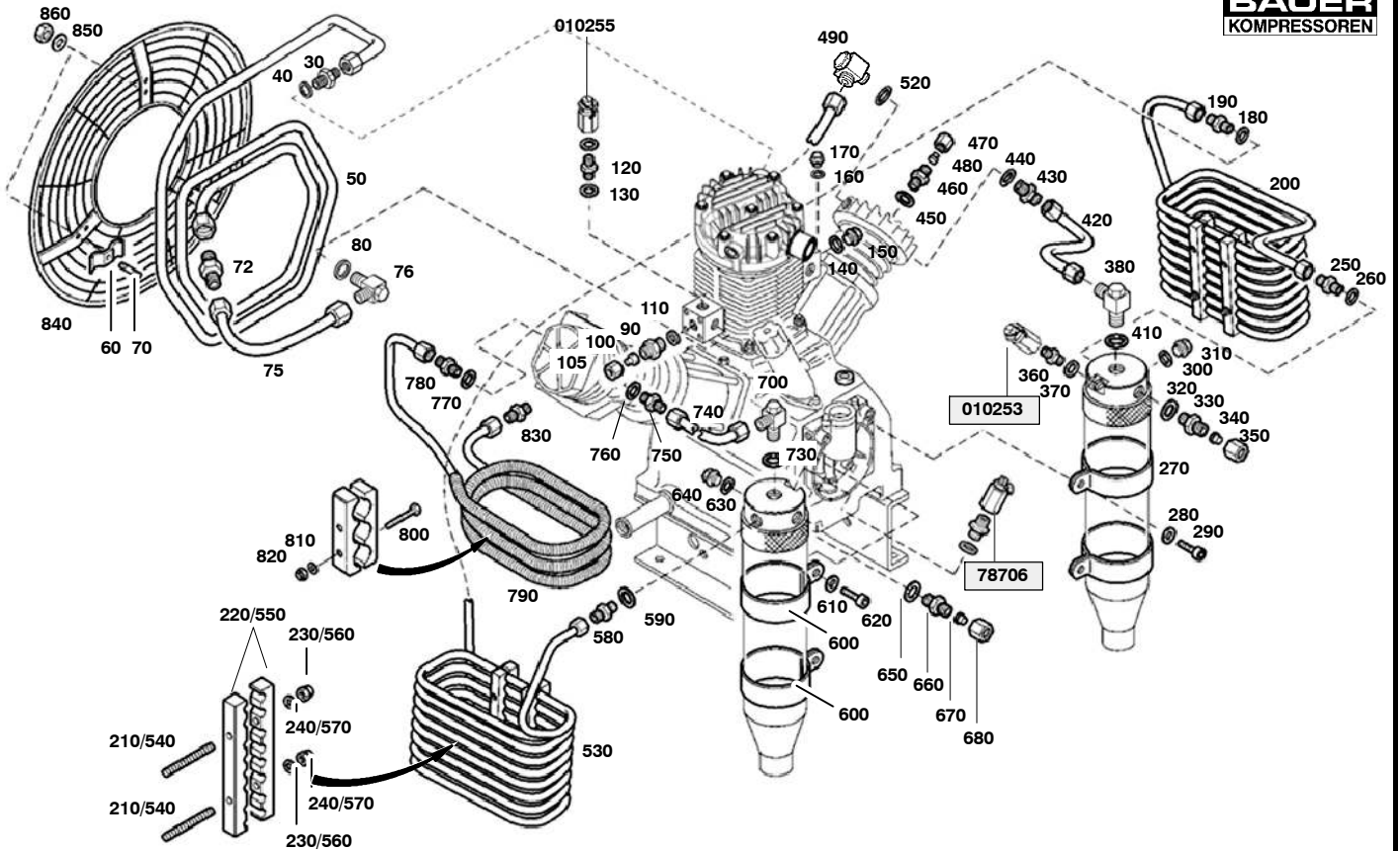



 Ersatzteilsätze  
 Spare parts sets  
 Kits de pièces dét.

 Baugruppe 81294  
 Assembly 81294  
 Assemblage 81294

 Kühlung  
 Cooling system  
 Refroidissement

**TM320-12**

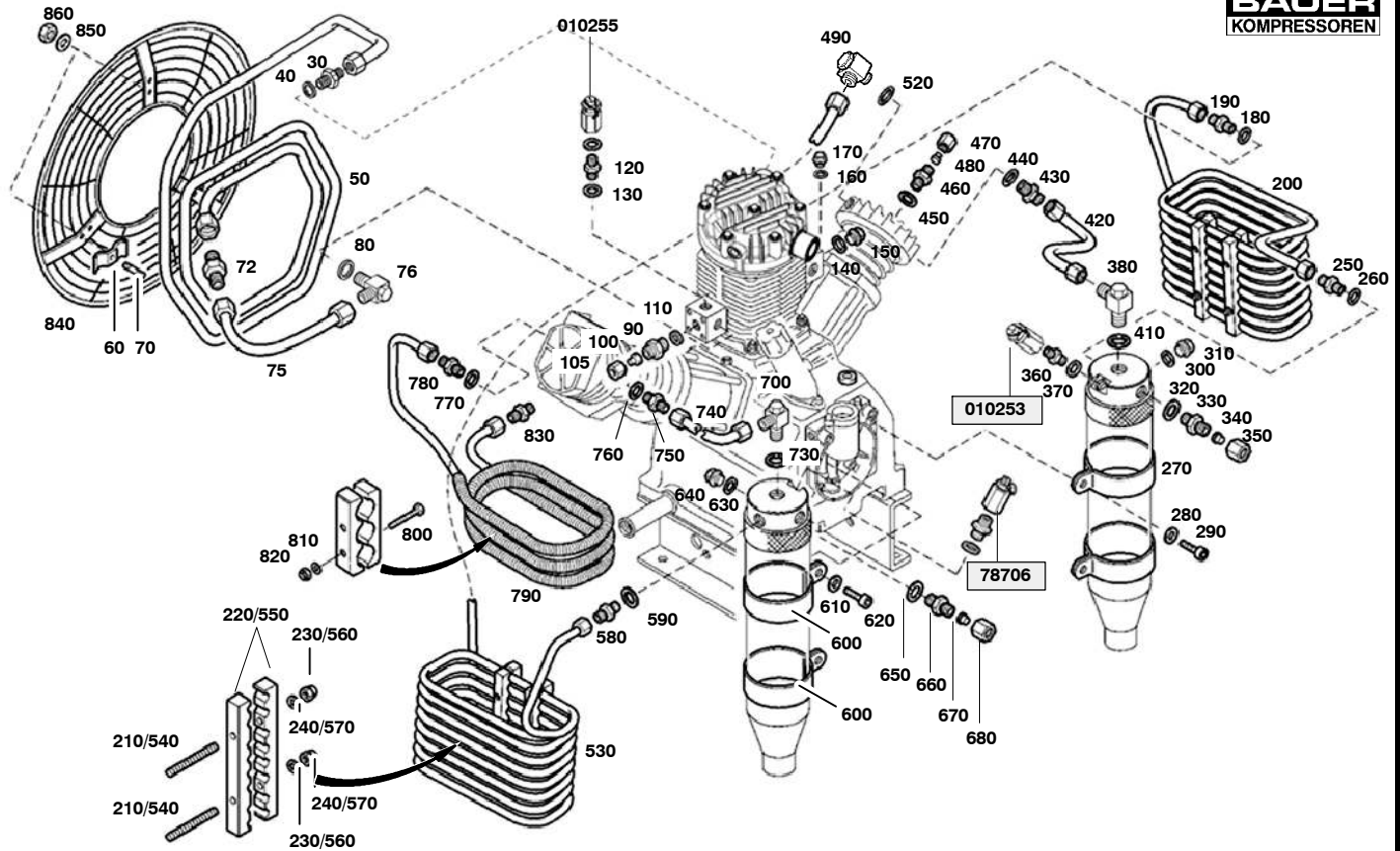
Klasse/ Class/ Classe			Pos.	Bestell-Nr. Part No. No. de cde.	Anz. Qty. Qté.	Benennung	Designation	Dénomination
a	b	c						
			30	N293	1	Dichtring	gasket	joint
			40	N20231	1	G-Einschraubstutzen	straight male connector	raccord droit mâle
			50	81303	1	Zwischenkühler kpl.	inter cooler assy.	refroid. intermédiaire cpl.
			60	11887	3	Schelle	double strap	collier double
			70	78199	3	Gewindestift	headless screw	vis sans tête
			72	N20202	1	G-Reduzierstutzen	straight reducer connector	raccord droit réducteur
			75	78584	1	Verbindungsleitung	connecting tube	tuyau de connexion
			76	N26751	1	Schwenkstutzen	connector	raccord
			80	N1316	1	Dichtring	gasket	joint
			90	N20195	1	G-Einschraubstutzen	straight male connector	raccord droit mâle
			100	N4530	1	Verschlussstopfen	plug	bouchon
			105	N3610	1	Überwurfmutter	screw cap	écrou borgne
			110	N1316	1	Dichtring	gasket	joint
			120	N20201	1	G-Einschraubstutzen	straight male connector	raccord droit mâle
			130	N1316	1	Dichtring	gasket	joint
			140	N1316	1	Dichtring	gasket	joint
			150	N52	1	Verschlusschraube	plug	bouchon fileté
			180	N1316	1	Dichtring	gasket	joint
			190	N20059	1	G-Einschraubstutzen	straight male connector	raccord
			200	80696	1	Zwischenkühler kpl.	inter cooler assy.	refroid. intermédiaire cpl.
			210	N3494	4	Stiftschraube	stud	goujon fileté
			220	62773	4	Fixierung	fixing for cooler	fixation de refroidisseur
			230	N102	4	Scheibe	washer	rondelle
			240	N1042	4	Sechskantmutter	hexagon nut self-locking	écrou hexagonal auto-frein.
			250	N20059	1	G-Einschraubstutzen	straight male connector	raccord droit mâle
			260	N1316	1	Dichtring	gasket	joint
			270	77894	2	Rohrschelle	clamp	collier



 Ersatzteilsätze  
 Spare parts sets  
 Kits de pièces dét.

 Baugruppe 81294  
 Assembly 81294  
 Assemblage 81294

 Kühlung  
 Cooling system  
 Refroidissement

**TM320-12**

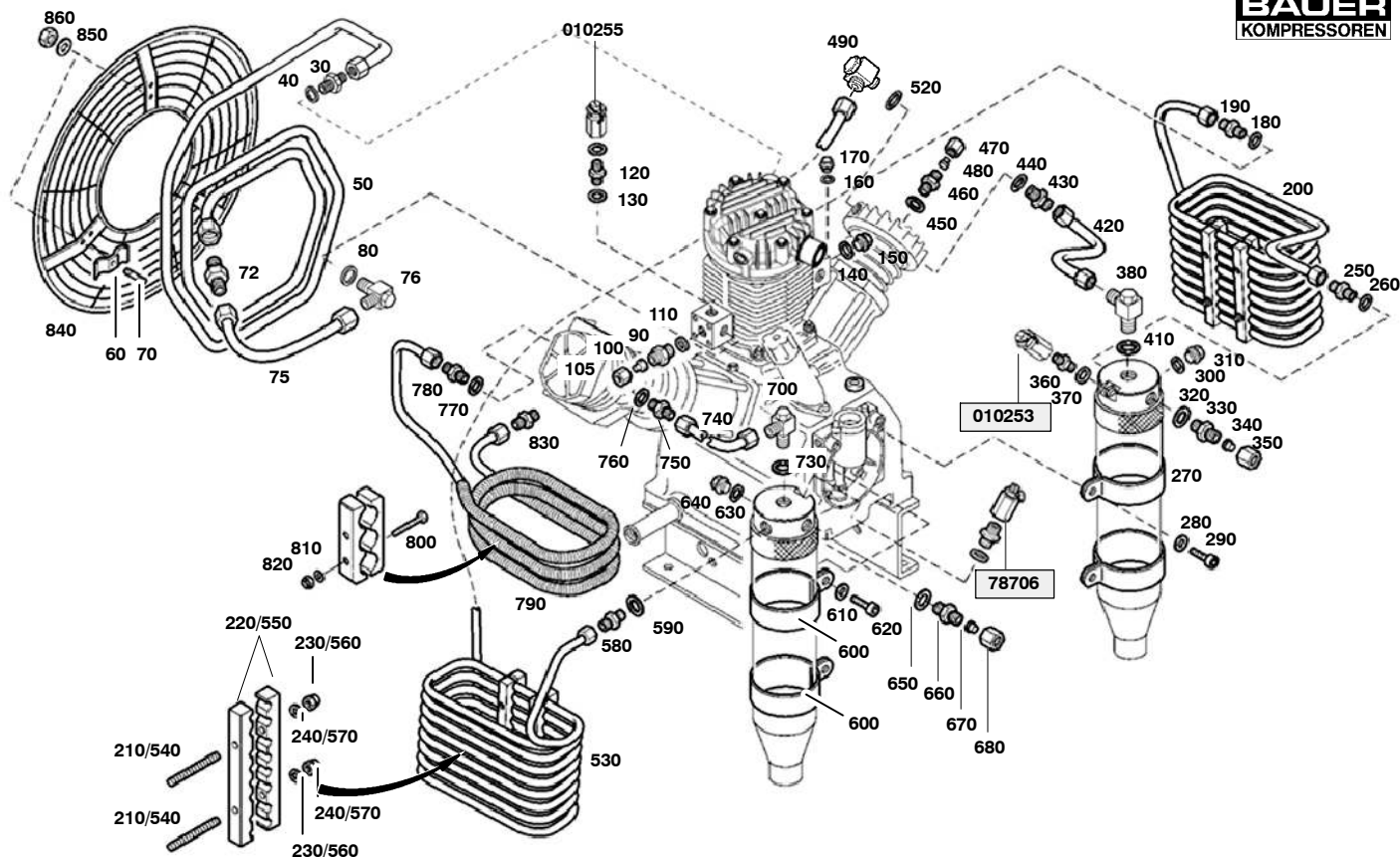
Klasse/ Class/ Classe			Pos.	Bestell-Nr. Part No. No. de cde.	Anz. Qty. Qté.	Benennung	Designation	Dénomination
a	b	c						
			280	N2460	2	Scheibe	washer	rondelle
			290	N88	2	Sechskantschraube	hexagon screw	vis hexagonale
			300	N1316	1	Dichtring	gasket	joint
			310	N52	1	Verschlußschraube	plug	bouchon fileté
			320	N1316	1	Dichtring	gasket	joint
			330	N20195	1	G-Einschraubstutzen	straight male connector	raccord droit mâle
			340	N4530	1	Verschlußstopfen	plug	bouchon
			350	N3610	1	Überwurfmutter	screw cap 6S	écrou borgne
			360	N20188	1	G-Einschraubstutzen	straight male connector	raccord droit mâle
			370	4479	1	Dichtring	gasket	joint
			380	N26751	1	Schwenkstutzen	connector	raccord
			410	N1316	1	Dichtring	gasket	joint
			420	78300	1	Verbindungsleitung kpl.	connecting tube assy.	tuyau de connexion cpl.
			430	N20059	1	G-Einschraubstutzen	straight male connector	raccord droit mâle
			440	N1316	1	Dichtring	gasket	joint
			450	N1316	1	Dichtring	gasket	joint
			460	N20195	1	G-Einschraubstutzen	straight male connector	raccord droit mâle
			470	N4530	1	Verschlußstopfen	plug	bouchon
			480	N3610	1	Überwurfmutter	screw cap 6S	écrou borgne
			490	N26751	1	Schwenkstutzen	connector	raccord
			520	N1316	1	Dichtring	gasket	joint
			530	78195	1	Zwischenkühler kpl.	inter cooler assy.	refroid. intermédiaire cpl.
			540	N3494	4	Stiftschraube	stud	goujon fileté
			550	62773	4	Fixierung	fixing for cooler	fixation de refroidisseur
			560	N102	4	Scheibe	washer	rondelle
			570	N1042	4	Sechskantmutter	hexagon nut self-locking	écrou hexagonal auto-frein.
			580	N20059	1	G-Einschraubstutzen	straight male connector	raccord droit mâle

 Ersatzteilsätze  
 Spare parts sets  
 Kits de pièces dét.

 Baugruppe 81294  
 Assembly 81294  
 Assemblage 81294

 Kühlung  
 Cooling system  
 Refroidissement

**TM320-12**

Klasse/ Class/ Classe			Pos.	Bestell-Nr. Part No. No. de cde.	Anz. Qty. Qté.	Benennung	Designation	Dénomination
a	b	c						
			590	N1316	1	Dichtring	gasket	joint
			600	77894	2	Rohrschelle	clamp	collier
			610	N2460	2	Scheibe	washer	rondelle
			620	N88	2	Sechskantschraube	hexagon screw	vis hexagonale
			630	N1316	1	Dichtring	gasket	joint
			640	N52	1	Verschlußschraube	plug	bouchon fileté
			650	N1316	1	Dichtring	gasket	joint
			660	N20195	1	G-Einschraubstutzen	straight male connector	raccord droit mâle
			670	N4530	1	Verschlußstopfen	plug	bouchon
			680	N3610	1	Überwurfmutter	screw cap 6S	écrou borgne
			700	N26751	1	Schwenkstutzen	connector	raccord
			730	N1316	1	Dichtring	gasket	joint
			740	78352	1	Verbindungsleitung kpl.	connecting tube assy.	tuyau de connexion cpl.
			750	N20059	1	G-Einschraubstutzen	straight male connector	raccord droit mâle
			760	N1316	1	Dichtring	gasket	joint
			770	56983	1	Dichtring	gasket	joint
			780	71148	1	Rohrverschraubung	connector	raccord
			790	78301	1	Nachkühler kpl.	after cooler assy.	refroidisseur final cpl.
			800	N3498	4	Sechskantschraube	hex. srew	écrou 6 pans
			810	N3313	4	Scheibe	washer	rondelle
			820	N1042	4	Sechskantmutter	hexagon nut self-locking	écrou hexagonal auto-frein.
			830	N20208	1	G-Stutzen	straight male connector	raccord droit mâle
			840	78200	1	Lüfterradchutz	fanwheel protector	protection de ventilateur
			850	N58	3	Scheibe	washer	rondelle
			860	N370	3	Sechskantmutter	hexagon nut self-locking	écrou hexagonal auto-frein.
			870	N1316	1	Dichtring	gasket	joint
			880	N20014	1	G-Einschraubstutzen	straight male connector	raccord droit mâle



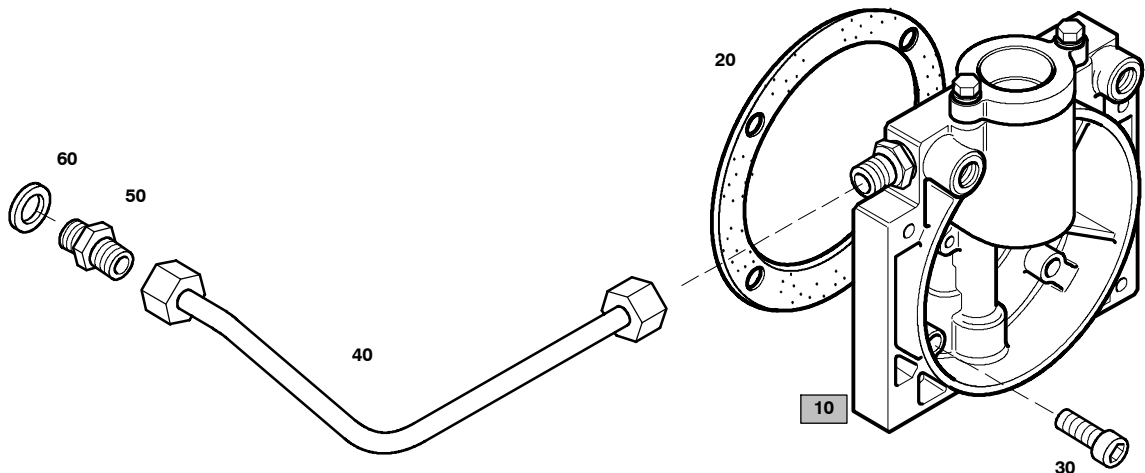

 Wartungssätze  
 Maintenance sets  
 Kits d'entretien

**Baugruppe** 81074  
**Assembly** 81074  
**Assemblage** 81074

**Druckölschmierung kpl.**  
**Lubricating system assy.**  
**Lubrification cpl.**
**TM320-13**

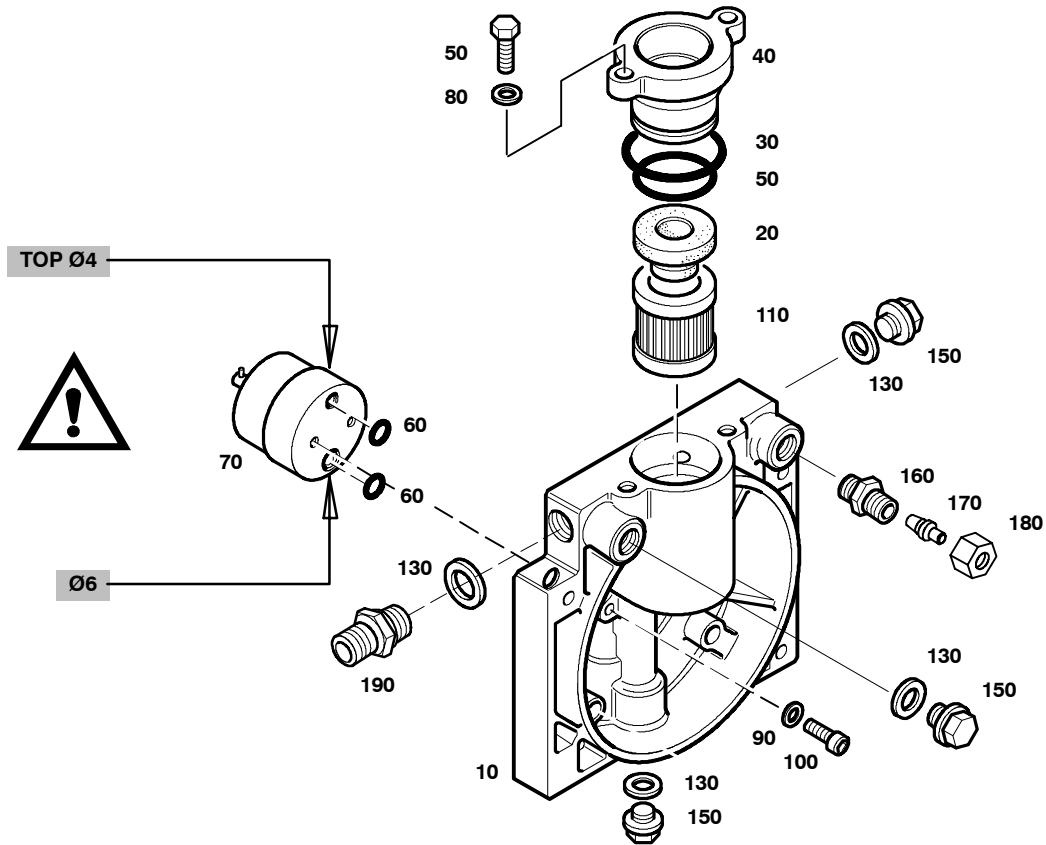
Klasse/ Class/ Classe			Pos .	Bestell-Nr. Part No. No. de cde.	Anz Qty. Qté.	Benennung	Designation	Dénomination
a	b	c						
			10	81075	1	Druckölschmierung	lubricating system	système de lubrification
			20	78421	1	Dichtung	gasket	joint
			30	N503	4	Zylinderschraube	allen screw	vis allen
			40	81200	1	Verbindungsleitung kpl.	connecting tube assy.	conduite cpl.
			50	N20002	1	G-Einschraubstutzen	straight coupling	raccord mâle droit
			60	N4051	1	Dichtring	gasket	joint

 Wartungssätze  
 Maintenance sets  
 Kits d'entretien

**Baugruppe** 81075  
**Assembly** 81075  
**Assemblage** 81075

**Druckölschmierung**  
**Lubricating system**  
**Système de lubrification**
**TM320-13a**

Klasse/ Class/ Classe			Pos. .	Bestell-Nr. Part No. No. de cde.	Anz. Qty. Qté.	Benennung	Designation	Dénomination
a	b	c						
			10	77878	1	Deckel	cover plate	couvercle
			20	77774	1	Dichtung	gasket	joint
			30	N4058	1	O-Ring	o-ring	joint torique
			40	77885	1	Deckel	für Ölfilter	Deckel
			50	N25327	1	O-Ring	o-ring	joint torique
			60	N3489	2	O-Ring	o-ring	joint torique
			70	N24585	1	Zahnradpumpe	pump	pompe
			80	N58	2	Scheibe	washer	rondelle
			90	N2889	2	Dichtring	gasket	joint
			100	N25328	2	Zylinderschraube	allen screw	vis allen
			110	N25326	1	Filterelement	filter insert	élément filtrant
			120	N19506	2	Sechskantschraube	hex. screw	vis à six pans
			130	N1316	4	Dichtring	gasket	joint
			150	N52	3	Verschlußschraube	plug screw	bouchon
			160	N20065	1	G-Einschraubstutzen	coupling	raccord
			170	N16309	1	Verschlußstopfen	plug	bouchon
			180	N1049	1	Überwurfmutter	screw cap	écrou chapeau
			190	81050	1	Regulierventil	regulator valve	soupape de régulation

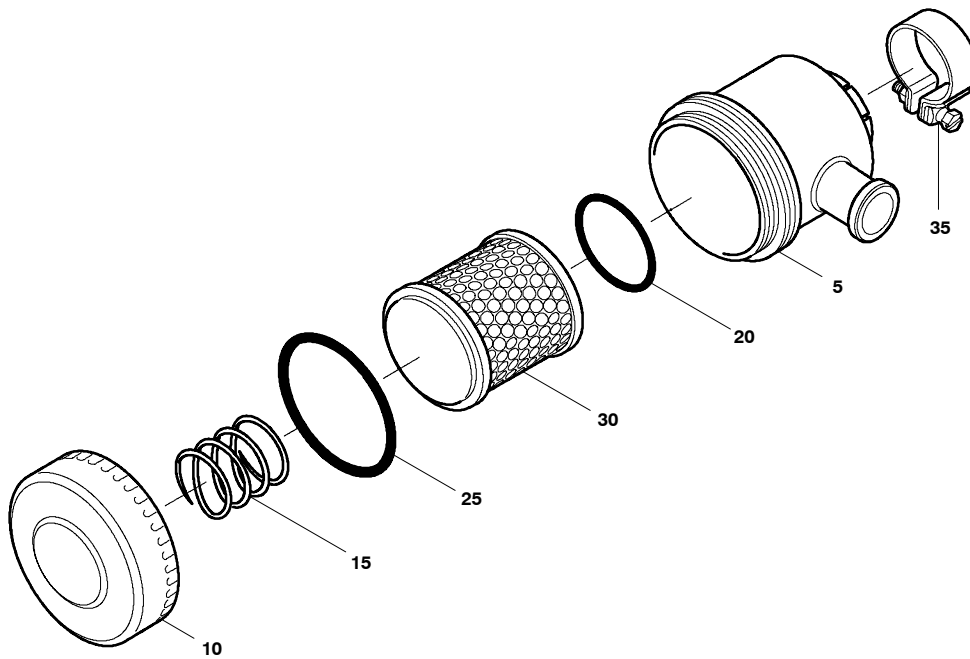
 Ersatzteilsätze  
 Spare parts sets  
 Kits de pièces dét.

<b>Baugruppe</b>	<b>013758</b>	<b>Ansaugfilter</b>
<b>Assembly</b>	<b>013758</b>	<b>Intake filter</b>
<b>Assemblage</b>	<b>013758</b>	<b>Filtre d'aspiration</b>

**TM320-14**

Klasse/ Class/ Classe			Pos.	Bestell-Nr. Part No. No. de cde.	Anz. Qty. Qté.	Benennung	Designation	Dénomination
a	b	c						
			5	12770	1	Ansaugfilter-Gehäuse	intake filter housing	boîtier de filtre
			10	12771	1	Ansaugfilter-Deckel	suction filter cover	couvercle de filtre
			15	10528	1	Druckfeder	pressure spring	ressort de pression
X			20	13757	1	O-Ring	o-ring	joint torique
X			25	N4451	1	O-Ring	o-ring	joint torique
X			30	N70	1	Filtereinsatz	filter insert	élément filtrant
			35	N3374	1	Schelle	clamp	collier

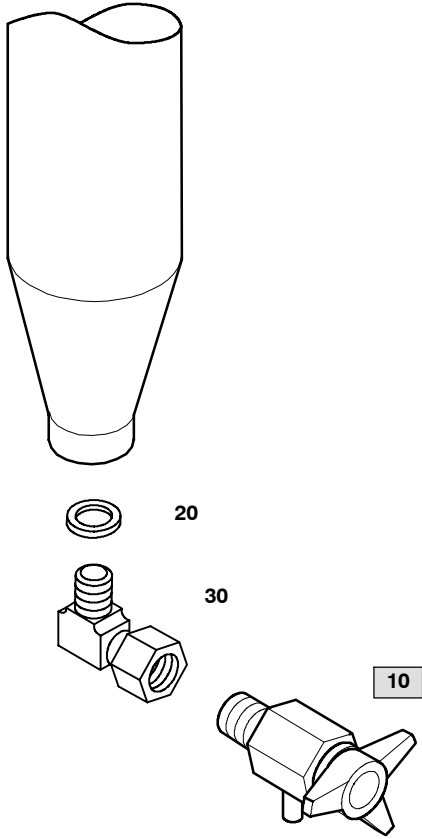

Wartungssätze  
Maintenance sets  
Kits d'entretien

**Baugruppe** 81758  
**Assembly** 81758  
**Assemblage** 81758

**Kondensatablaßhahn**  
**Condensate drain tap**  
**Robinet de purge**

**TM320-15**

Klasse/ Class/ Classe			Pos.	Bestell-Nr. Part No. No. de cde.	Anz. Qty. Qté.	Benennung	Designation	Dénomination
0	2	5						
			10	011430	1	Ablaßhahnkörper, kpl.	drain valve body	corps de robinet de purge
X			20	N19368	1	Dichtung	gasket	joint
			40	N26972	1	W-Verschraubung	elbow coupling	coude

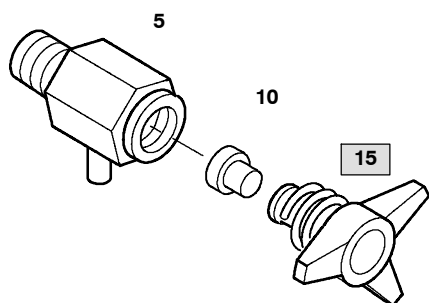
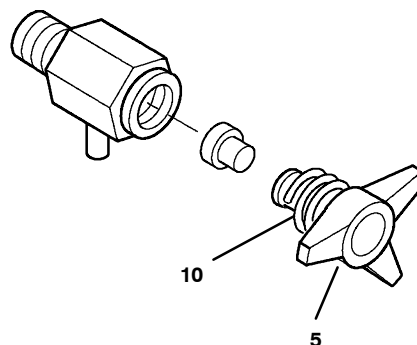

**TM320-15a**

**TM320-15b**

 Wartungssätze  
 Maintenance sets  
 Kits de maintenance

**Baugruppe** 011430  
**Assembly** 011430  
**Assemblage** 011430

**Kondensatablaßhahn**  
**Condensate drain tap**  
**Robinet de purge**
**TM320-15a**

Klasse/ Class/ Classe			Pos.	Bestell-Nr. Part No. No. de cde.	Anz. Qty. Qté.	Benennung	Designation	Dénomination
0	2	5						
			5	068410	1	Ablaßhahnkörper, kpl.	drain valve housing	corps de robinet de purge
X			10	13283	1	Dichtung	gasket	joint
			15	055888	1	Knebelschraube m. Feder	tommy screw with spring	molette avec ressort

 Wartungssätze  
 Maintenance sets  
 Kits de maintenance

**Baugruppe** 055888  
**Assembly** 055888  
**Assemblage** 055888

**Knebelschraube mit Sicherungsfeder**  
**Tommy screw with retaining spring**  
**Molette avec ressort**
**TM320-15b**

Klasse/ Class/ Classe			Pos.	Bestell-Nr. Part No. No. de cde.	Anz. Qty. Qté.	Benennung	Designation	Dénomination
a	b	c						
			5	11392	1	Knebelschraube	tommy screw	molette
			10	13284	1	Sicherungsfeder	locking spring	ressort d'arrêt

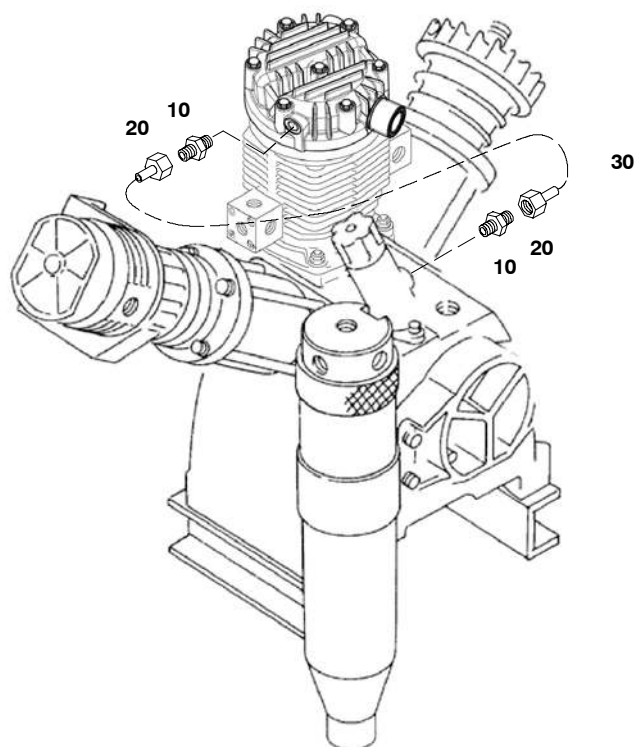
 Wartungssätze  
 Maintenance sets  
 Kits d'entretien

**Baugruppe** 81567  
**Assembly** 81567  
**Assemblage** 81567

**Zubehör**  
**Accessories**  
**Accessoires**
**TM320-16**

Klasse/ Class/ Classe			Pos.	Bestell-Nr. Part No. No. de cde.	Anz. Qty. Qté.	Benennung	Designation	Dénomination
a	b	c						
			10	N1316	1	Dichtring	gasket	joint
			20	N20014	1	G-Einschraubstutzen	male connector	raccord droit mâle
			30	81306	1	Verbindungsleitung kpl.	connecting tube assy.	conduite de liaison cpl.

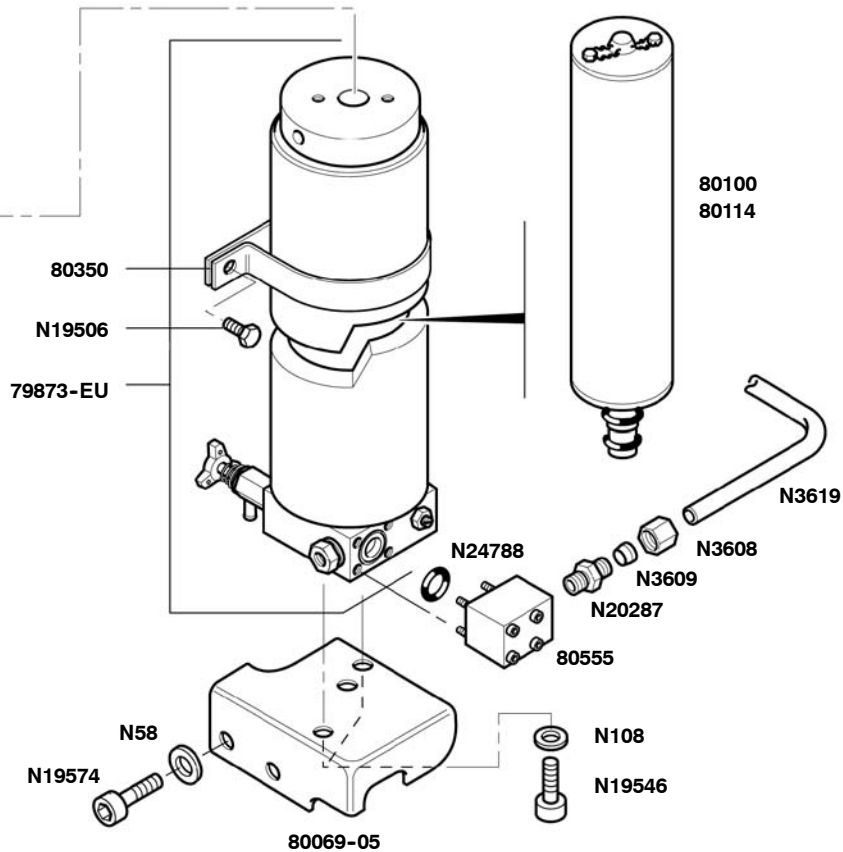
059410-225  
 059410-225TÜV  
 059410-330  
 059410-330TÜV

 Wartungssätze  
 Maintenance sets  
 Kits d'entretien

**Baugruppe** 80067  
**Assembly** 80067  
**Assemblage** 80067

**Filtersystem P31**  
**Filter system P31**  
**Système de filtration P31**
**TM320-17**

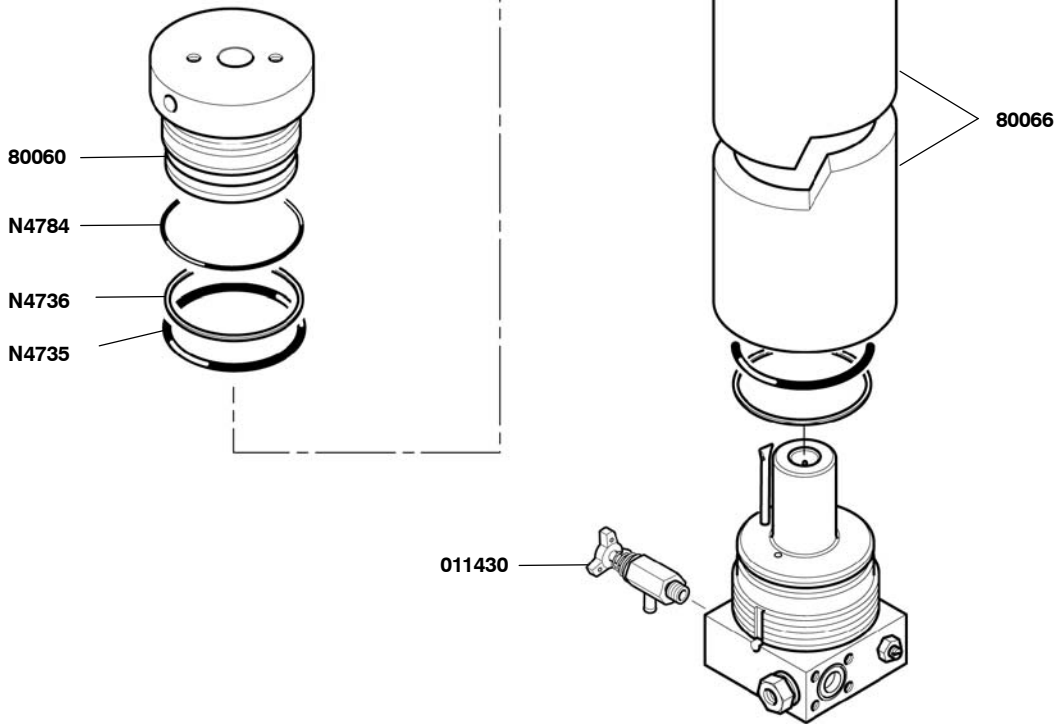
Klasse/ Class/ Classe			Bestell-Nr. Part No. No. de cde.	Benennung	Designation	Dénomination
a	b	c				
			059410-225	Sicherheitsventil 225 bar	Safety valve 225 bar	Soupape de sûreté 225 bar
			059410-225TUV	Sicherheitsventil 225 bar m. TÜV	Safety valve 225 bar w. TÜV	Soupape de sûreté 225 bar avec TÜV
			059410-330	Sicherheitsventil 330 bar	Safety valve 330 bar	Soupape de sûreté 330 bar
			059410-330TUV	Sicherheitsventil 330 bar m. TÜV	Safety valve 330 bar w. TÜV	Soupape de sûreté 330 bar avec TÜV
			79873-EU	Filter P31 (ohne Patrone)	Filter P21 (without cartridge)	Syst. P21 (sans cartouche)
			80069-05	Halterung	bracket	fixation
			80100	Filterpatrone MS-AC	filter cartridge MS-AC	cartouche filtrante MS-AC
			80114	Filterpatrone MS-AC-HP	filter cartridge MS-AC-HP	cartouche filtrante MS-AC-HP
			80350	Rohrschelle	tube clamp	collier
			80555	Rückschlagventil	non-return valve	soupape anti-retour
			N58	Scheibe	washer	rondelle
			N108	Federring	lock washer	rondelle élastique
			N3608	Überwurfmutter	cap screw	écrou
			N3609	Schneidring	cutting ring	écrou borgne
			N3619	Rohr	tube	tuyau
			N19547	Zylinderschraube	allen screw	vis six pans creux
			N19546	Zylinderschraube	allen screw	vis six pans creux
			N19506	Sechskantschraube	hex. screw	vis hex.
			N20287	G-Einschraubstutzen	male connector	raccord droit mâle
			N24788	O-Ring	o-ring	joint torique



Wartungssätze  
Maintenance sets  
Kits d'entretien

**Baugruppe** 79873-EU Filterbehälter  
**Assembly** 79873-EU Filter housing  
**Assemblage** 79873-EU Corps du filtre

**TM320-17a**

Klasse/ Class/ Classe			Bestell-Nr. Part No.	Benennung	Designation	Dénomination
a	b	c	No. de cde.			
			011430	Kondensatablaßhahn kpl.	condensate drain tap assy.	robinet de purge cpl.
			80060*	Filterkopf	filter head	tête de filtre
			80066*	Filtergehäuse	filter housing	corps du filtre
			80593*	Filterboden kpl.	filter base part assy	base de filtre
			N4735	O-Ring	o-ring	joint torique
			N4736	Stützring	backup ring	bague d'appui
			N4784	O-Ring	o-ring	joint torique

		*	nur zusammen lieferbar	available only as a set	ne sont livrées qu'ensemble
--	--	---	------------------------	-------------------------	-----------------------------

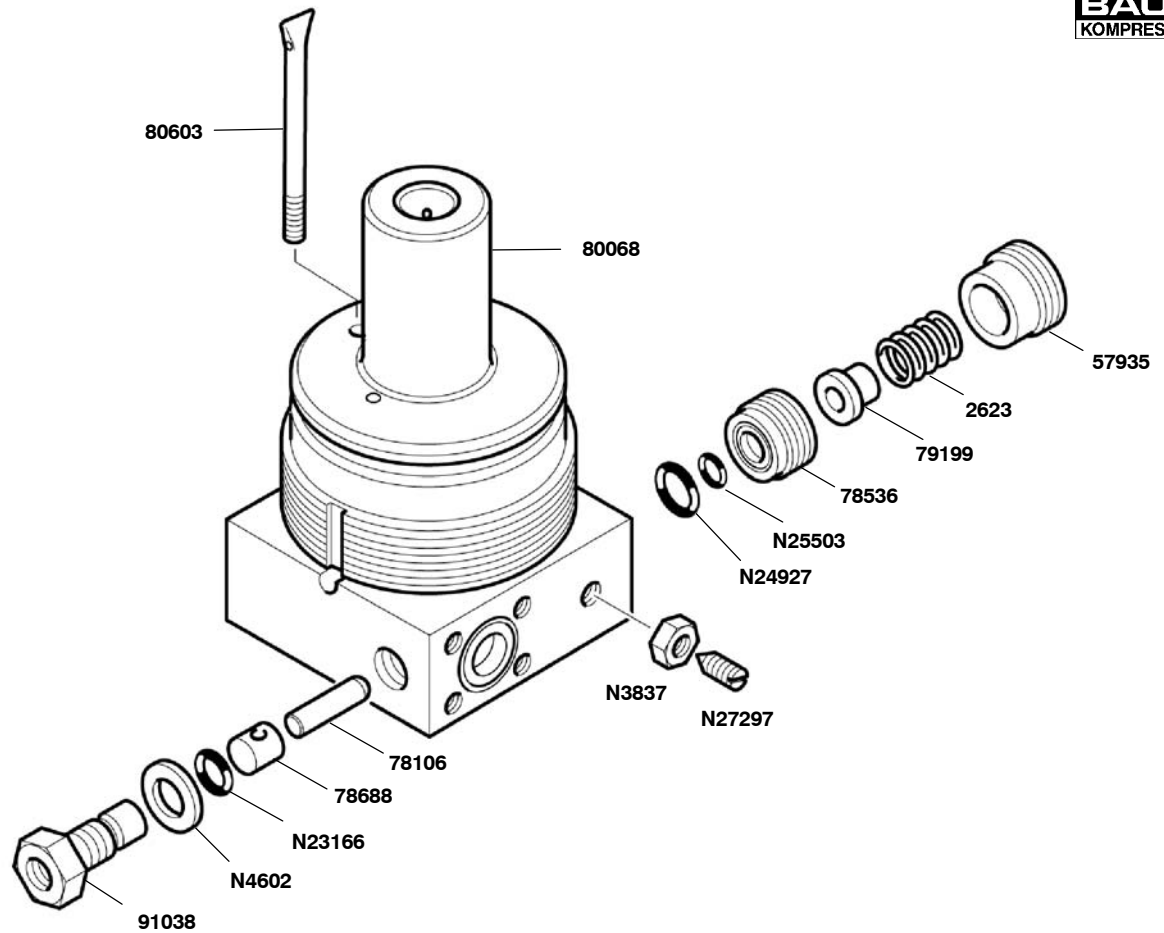
 Wartungssätze  
 Maintenance sets  
 Kits d'entretien

**Baugruppe** 80593  
**Assembly** 80593  
**Assemblage** 80593

**Behälterboden kpl.**  
**Filter base part assy.**  
**Base du filtre cpl.**
**TM320-17b**

Klasse/ Class/ Classe			Bestell-Nr. Part No. No. de cde.	Benennung	Designation	Dénomination
a	b	c				
			2623	Druckfeder	spring	ressort de pression
			57935	Einstellschraube	adjusting screw	vis d'ajustage
	X		78106	Zylinderstift	cylindric pin	tige cylindrique
			78536	Aufnahme	seat	siège
			78688	Ventilkolben	valve piston	piston
			79199	Federaufnahme	spring seat	siège de ressort
			80068	Boden	base	base
			80603	Spritzrohr	nozzle	buse
			91038	Ventilsitz	valve seat	siège de soupape
			N3837	Sechskantmutter	hex nut	écrou hex.
			N27297	Gewindestift	set screw	goujon fileté
			N4602	USIT-Ring	usit-ring	joint usit
			N23166	O-Ring	o-ring	joint torique
			N24927	O-Ring	o-ring	joint torique
			N25503	O-Ring	o-ring	joint torique

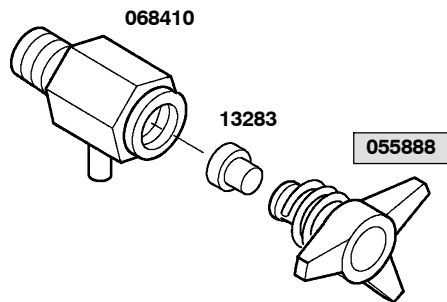
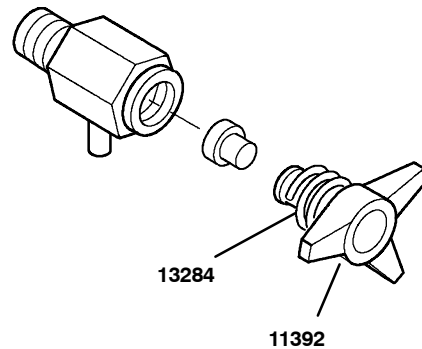
**TM320-17c**

**TM320-17d**

 Wartungssätze  
 Maintenance sets  
 Kits d'entretien

<b>Baugruppe</b>	<b>011430</b>	<b>Kondensatablaßhahn</b>
<b>Assembly</b>	<b>011430</b>	<b>Condensate drain tap</b>
<b>Assemblage</b>	<b>011430</b>	<b>Robinet de purge</b>

**TM320-17c**

Klasse/ Class/ Classe			Bestell-Nr. Part No.	Benennung	Designation	Dénomination
a	b	c	No. de cde.			
			068410	Ablaßhahnkörper, kpl.	drain valve housing	corps de robinet de purge
X			13283	Dichtung	gasket	joint
			055888	Knebelschraube m. Feder	tommy screw with spring	molette avec ressort

 Wartungssätze  
 Maintenance sets  
 Kits d'entretien

<b>Baugruppe</b>	<b>055888</b>	<b>Knebelschraube mit Sicherungsfeder</b>
<b>Assembly</b>	<b>055888</b>	<b>Tommy screw with retaining spring</b>
<b>Assemblage</b>	<b>055888</b>	<b>Molette avec ressort</b>

**TM320-17d**

Klasse/ Class/ Classe			Bestell-Nr. Part No.	Benennung	Designation	Dénomination
a	b	c	No. de cde.			
			11392	Knebelschraube	tommy screw	molette
			13284	Sicherungsfeder	locking spring	ressort d'arrêt

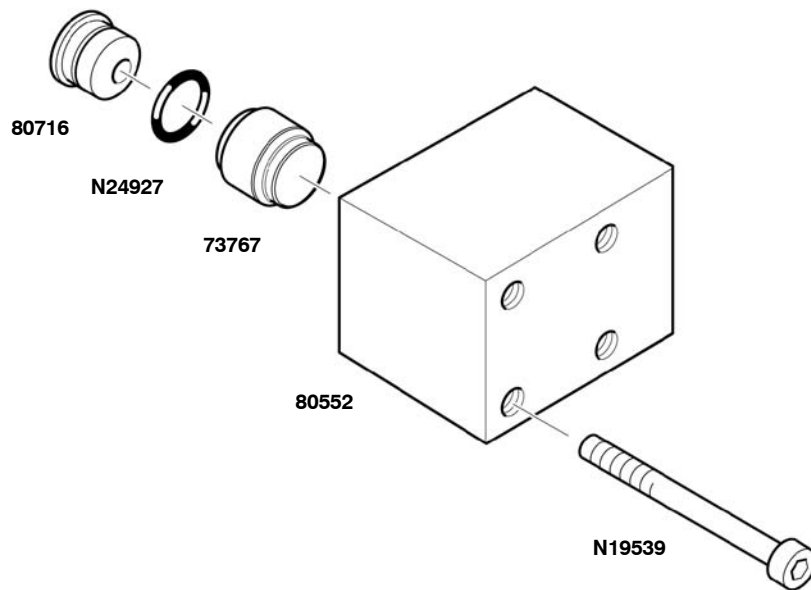
 Wartungssätze  
 Maintenance sets  
 Kits d'entretien

**Baugruppe** 80555  
**Assembly** 80555  
**Assemblage** 80555

**Rückschlagventil**  
**Non-return valve assy.**  
**Soupape anti-retour cpl.**
**TM320-17e**

Klasse/ Class/ Classe			Bestell-Nr. Part No.	Benennung	Designation	Dénomination
a	b	c	No. de cde.			
			80552	Ventilkörper	Valve housing	Corps de soupape
			80716	Rückschlagventilsitz	Valve seat	Siège de soupape
X			N24927	O-Ring	O-ring	Joint torique
			73767	Ventilkolben	Valve piston	Piston
			N19539	Innensechskantschraube	Allen screw	Vis à six pans creux

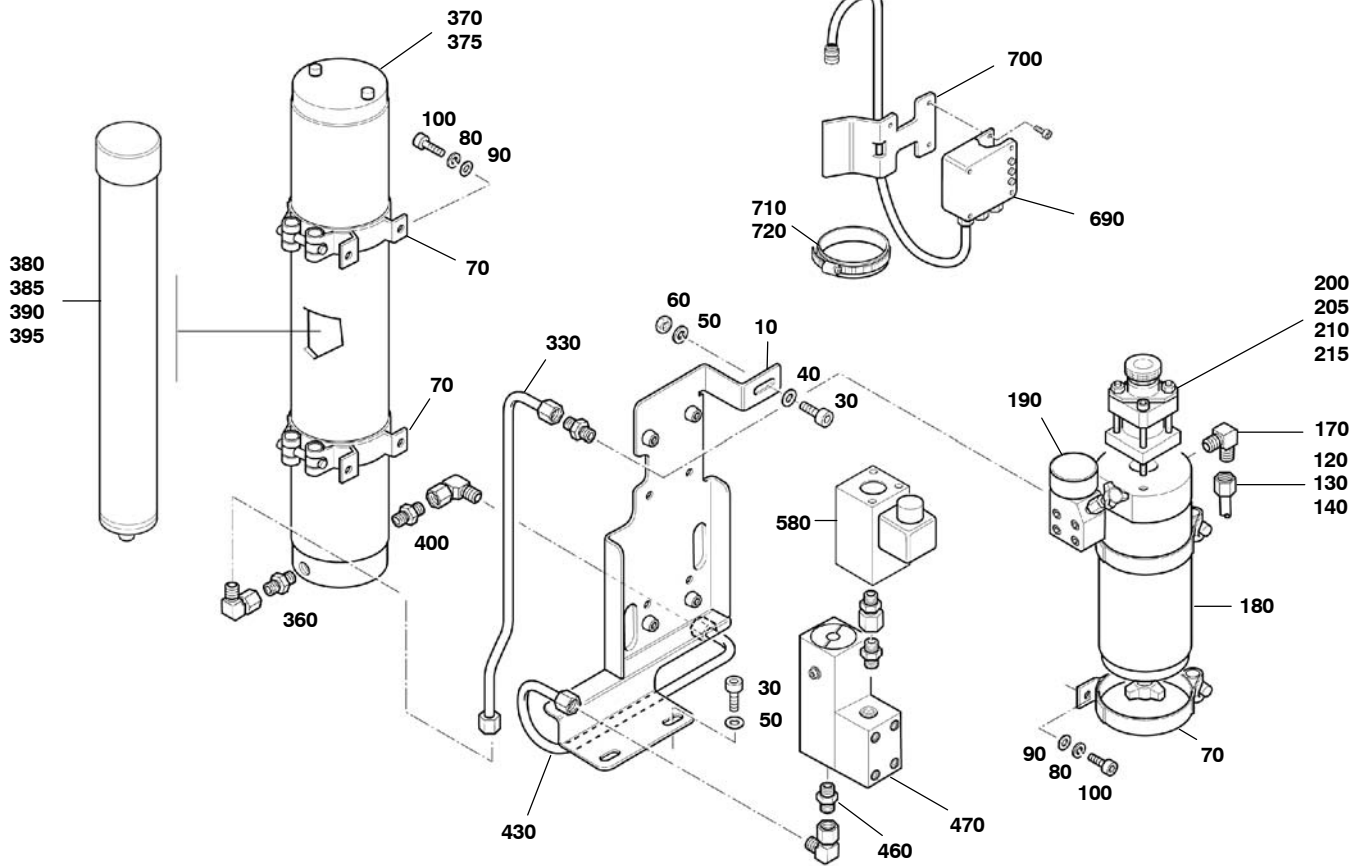

 Wartungssätze  
 Maintenance kits  
 Kits d'entretien

**Baugruppe** 80514  
**Assembly** 80514  
**Assemblage** 80514

**Filtersystem P41 (Zusatzausstattung**  
**Filtersystem P41 (optional extra)**  
**Système de filtration P41 (optionnel)**
**TM320-18**

Klasse/ Class/ Classe			Pos.	Bestell-Nr. Part No. No. de cde.	Benennung	Designation	Dénomination
a	b	c					
			10	80515	Halterung	braket	fixation
			30	N19534	Zylinderschraube	cylinder screw with IN-6KT	vis cylindrique avec IN-6KT
			40	N102	Scheibe	washer	rondelle
			50	N100	Federring	spring washer	rondelle-ressort
			60	N1042	Sechskantmutter	hexagon nut self-locking	écrou six pans auto-bloquant
			70	N26517	Schelle	clamp	collier
			80	N58	Scheibe	washer	rondelle
			90	N108	Federring	spring washer	rondelle-ressort
			100	N19547	Zylinderschraube	allen screw	vis allen
			110	N20208	G-Stutzen	connector	raccord
			120	N3609	Schneidring	cutting ring	rondelle de matrice
			130	N3608	Überwurfmutter	screw cap	écrou-chapeau
			140	N3619	Rohr	stainless steel tube 8x1.5	tuyau en acier inox 8x1.5
			150	N3608	Überwurfmutter	screw cap	écrou-chapeau
			160	N3609	Schneidring	cutting ring	rondelle de matrice
			170	N20270	Einst. W-Stutzen	connector	raccord
			<b>180</b>	<b>090058-EU</b>	<b>Öl- und Wasserabscheider</b>	<b>oil and water separator</b>	<b>séparateur d'huile et d'eau</b>
			<b>190</b>	<b>78122</b>	<b>Rückschlagventil</b>	<b>non-return valve</b>	<b>clapet anti-retour</b>
			200	059410-225	Sicherheitsventil	safety valve	soupape de sûreté 225bar
			205	059410-225T ÜV	Sicherheitsventil	safety valve	soupape de sûreté 225bar
			210	059410-330	Sicherheitsventil	safety valve	soupape de sûreté 330bar
			215	059410-330T ÜV	Sicherheitsventil	safety valve	soupape de sûreté 330bar
			220	N4570	Verschlußschraube	plug	bouchon fileté
			230	N20270	Einst. W-Stutzen	connector	raccord
			240	N3609	Schneidring	cutting ring	rondelle de matrice
			250	N3608	Überwurfmutter	screw cap	écrou-chapeau
			260	N3619	Rohr	stainless steel tube 8x1.5	tuyau en acier inox 8x1.5
			300	N20287	G-Einschraubstutzen	union	raccord
			310	N3609	Schneidring	cutting ring	rondelle de matrice
			320	N3608	Überwurfmutter	screw cap	écrou-chapeau
			330	N3619	Rohr	stainless steel tube 8x1.5	tuyau en acier inox 8x1.5

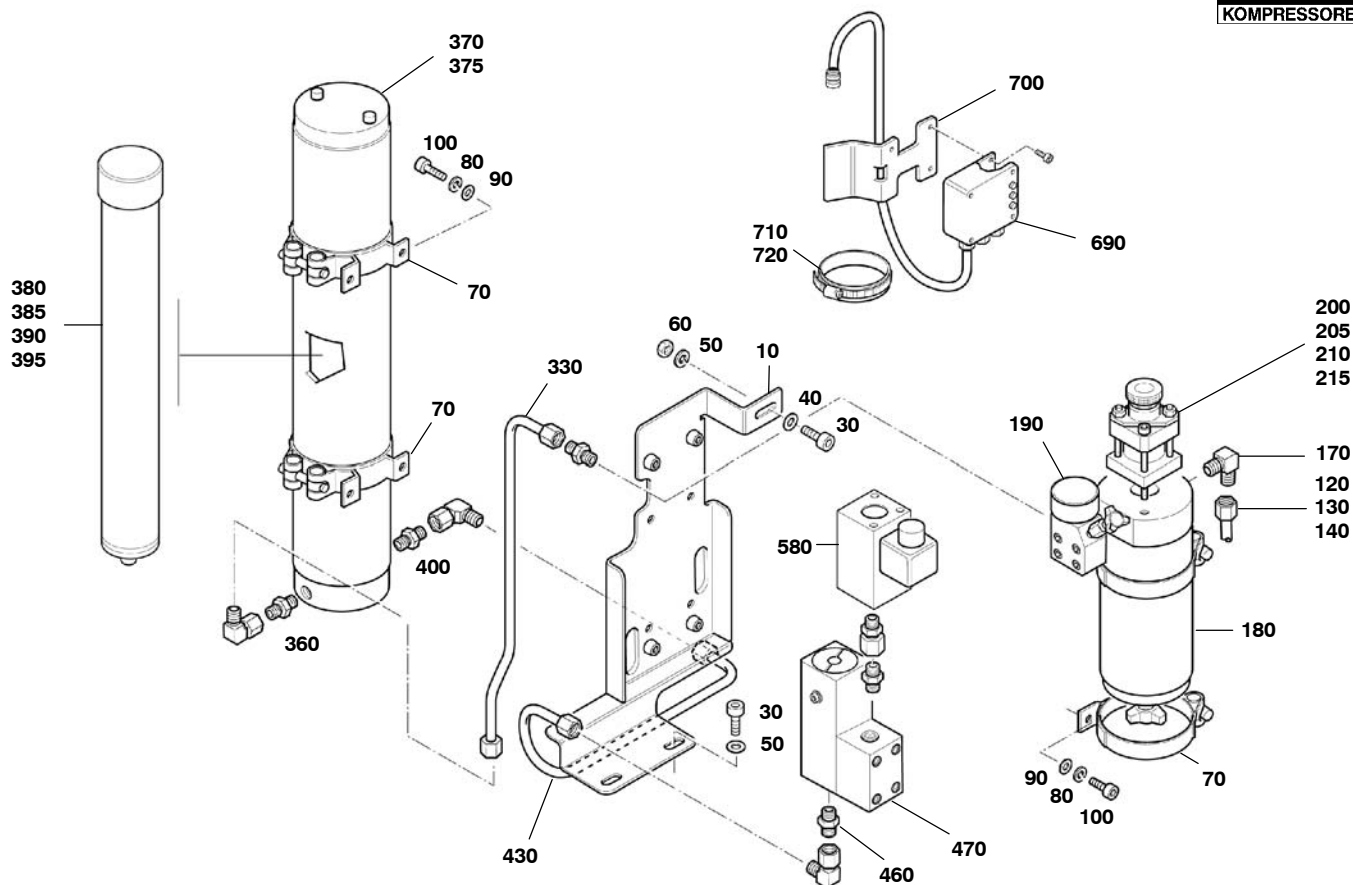



 Wartungssätze  
 Maintenance kits  
 Kits d'entretien

**Baugruppe** 80514  
**Assembly** 80514  
**Assemblage** 80514

**Filtersystem P41 (Zusatzausstattung)**  
**Filtersystem P41 (optional extra)**  
**Système de filtration P41 (optionnel)**
**TM320-18**

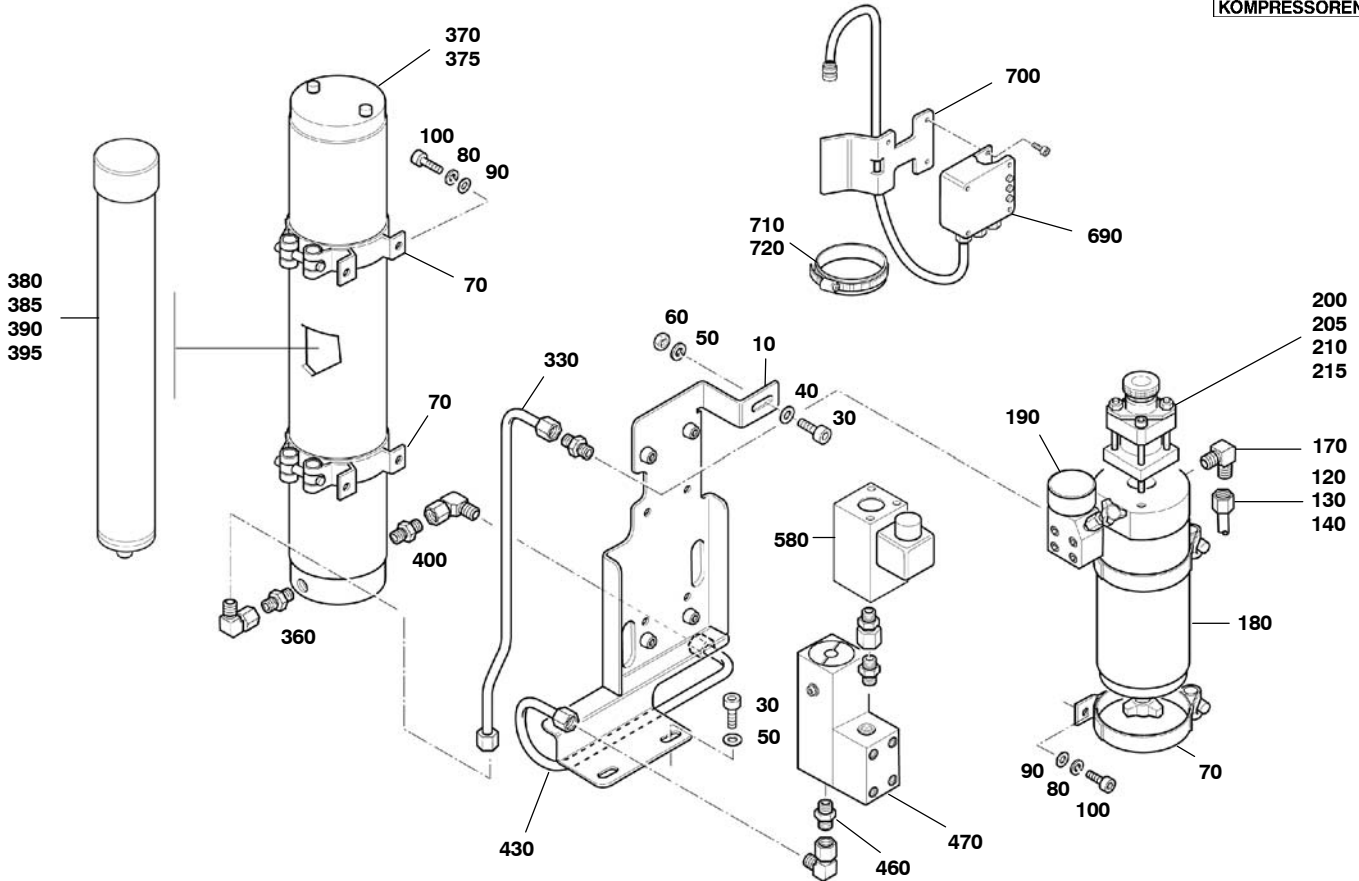
Klasse/ Class/ Classe			Pos.	Bestell-Nr. Part No. No. de cde.	Benennung	Designation	Dénomination
a	b	c					
			340	N3608	Überwurfmutter	screw cap	écrou-chapeau
			350	N3609	Schneidring	cutting ring	rondelle de matrice
			360	N20287	G-Einschraubstutzen	union	raccord
			<b>370</b>	<b>090960-EU</b>	<b>Filterbehälter</b>	<b>filter housing</b>	<b>corps de filtre</b>
			<b>375</b>	<b>062042-EU</b>	<b>Filterbehälter</b>	<b>filter housing</b>	<b>corps de filtre</b>
			380	062565	Filterpatrone	filter cartridge	cartouche multiplex MS-AC
			385	067224	Filterpatrone	filter cartridge	cartouche multiplex MS-AC-MS-HP
			390	061686	Filterpatrone Securus	filter cartridge Securus	cartouche multisecc MS-AC-MS
			395	061687	Filterpatrone	filter cartridge Securus	cartouche multisecc MS-AC-MS-HP
			400	N20287	G-Einschraubstutzen	union	raccord
			410	N3609	Schneidring	cutting ring	rondelle de matrice
			420	N3608	Überwurfmutter	screw cap	écrou-chapeau
			430	N3619	Rohr	stainless steel tube 8x1.5	tuyau en acier inox 8x1.5
			440	N3608	Überwurfmutter	screw cap	écrou-chapeau
			450	N3609	Schneidring	cutting ring	rondelle de matrice
			460	N20287	G-Einschraubstutzen	union	raccord
			<b>470</b>	<b>80751</b>	<b>Druckhalte-Rückschlagventil</b>	<b>pressure maintaining and non-</b>	<b>soupape de maintien de pression</b>
			580	N1010	Druckschalter	pressure switch 100-400bar	manostat
			590	N2949	Scheibe	washer	rondelle
			600	N635	Federring	spring washer	rondelle ressort
			610	N3869	Zylinderschraube	allen screw	vis à six pans creux
			620	N20211	G-Einschraubstutzen	straight male stud	raccord
			630	N3663	Schneidring	cutting ring 6L/S	rondelle de matrice
			640	N3610	Überwurfmutter	screw cap 6S	écrou-chapeau
			650	N3619	Rohr	stainless steel tube 8x1.5	tuyau en acier inox 8x1.5
			660	N3610	Überwurfmutter	screw cap 6S	écrou-chapeau
			670	N3663	Schneidring	cutting ring 6L/S	rondelle de matrice
			680	N20211	G-Einschraubstutzen	straight male stud	raccord
			690	N18362	Securus-Meldegerät	SECURUS indicator unit	dispositif de surveillance
			700	75377	Halterung	bracket	fixation
			701	N19534	Zylinderschraube	cylinder screw with IN-6KT	vis cylindrique avec IN-6KT
			702	N102	Scheibe	washer	rondelle
			703	N1042	Sechskantmutter	hexagon nut self-locking	écrou six pans auto-bloquant



Wartungssätze  
Maintenance kits  
Kits d'entretien

**Baugruppe** 80514  
**Assembly** 80514  
**Assemblage** 80514

**Filtersystem P41 (Zusatzausstattung)**  
**Filtersystem P41 (optional extra)**  
**Système de filtration P41 (optionnel)**

**TM320-18**

Klasse/ Class/ Classe			Pos.	Bestell-Nr. Part No. No. de cde.	Benennung	Designation	Dénomination
a	b	c					
			710	N15499	Schlauchschelle	worm gear clamp	collier à filet hélicoïdal
			720	N15500	Gummiprofil	rubber profile	profilé en caoutchouc

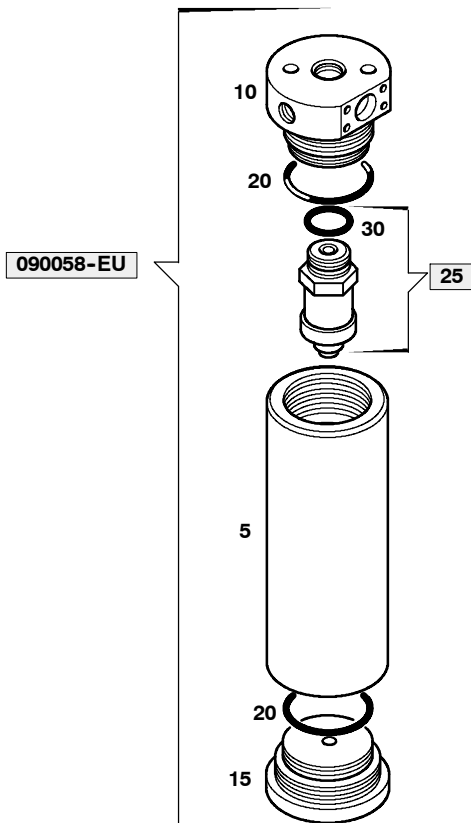
 Wartungssätze  
 Maintenance kits  
 Kits d'entretien

**Baugruppe** 090058-EU **Öl- und Wasserabscheider**  
**Assembly** 090058-EU **Oil and water separator**  
**Assemblage** 090058-EU **Séparateur d'huile et d'eau**
**TM320-18a**

Klasse/ Class/ Classe			Pos.	Bestell-Nr. Part No. No. de cde.	Anz. Qty. Qté.	Benennung	Designation	Dénomination
a	b	c						
			5	*	1	Behältergehäuse	filter housing	corps de filtre
			10	*	1	Behälterdeckel	filter head	tête de filtre
			15	*	1	Behälterboden	filter bottom	fond de filtre
X			20	N4586	2	O-Ring	o-ring	joint torique
X			25	061860	1	Microfilterpatrone	filter cartridge	cartouche de filtre

			30	N15133	1	O-Ring	o-ring	joint torique
--	--	--	----	--------	---	--------	--------	---------------

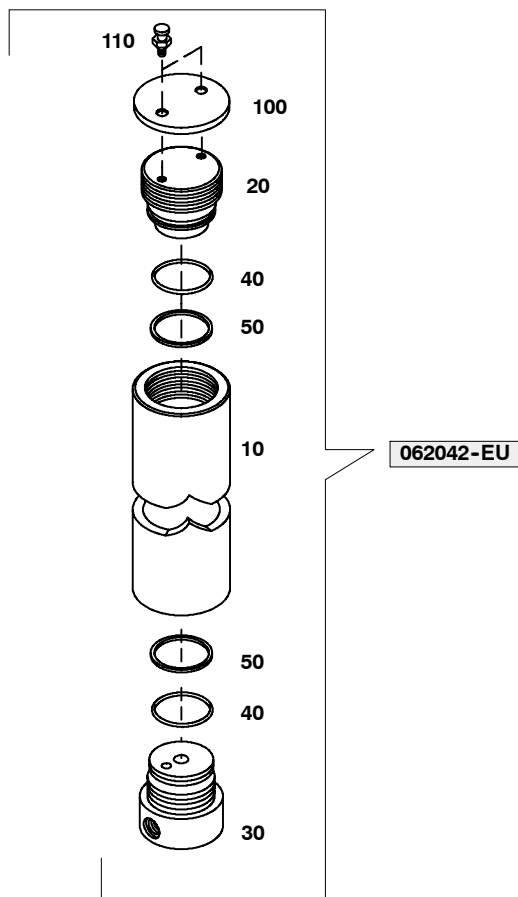

062042/07/02

 Wartungssätze  
 Maintenance kits  
 Kits d'entretien

**Baugruppe** 062042-EU **Filterbehälter kpl.**  
**Assembly** 062042-EU **Filter housing assy.**  
**Assemblage** 062042-EU **Corps du filtre cpl.**
**TM320-18b**

Klasse/ Class/ Classe			Pos.	Bestell-Nr. Part No. No. de cde.	Anz. Qty. Qté.	Benennung	Designation	Dénomination
a	b	c						
			10	*	1	Behältergehäuse	filter housing	corps de filtre
			20	*	1	Behälterdeckel kpl.	filter head	couvercle de filtre
			30	*	1	Behälterboden	filter bottom	fond de filtre
X			40	N4736	2	Stützring	back-up ring	bague d'appui
X			50	N4735	2	O-Ring	o-ring	joint torique
			60	78528	1	Fabricschild	Ident. plate	plaque d'identification
			70	N3334	1	Niete	semitubular rivet	rivet semi-tubulaire
			80	N3333	3	Blindniete	pop rivet	rivet aveugle
			90	91024	1	Klebeschild	sticker	autocollant
			100	61237	1	Schutzdeckel	protective cover	couvercle protecteur
			110	12293	2	Schraube	screw	vis

061685-EU

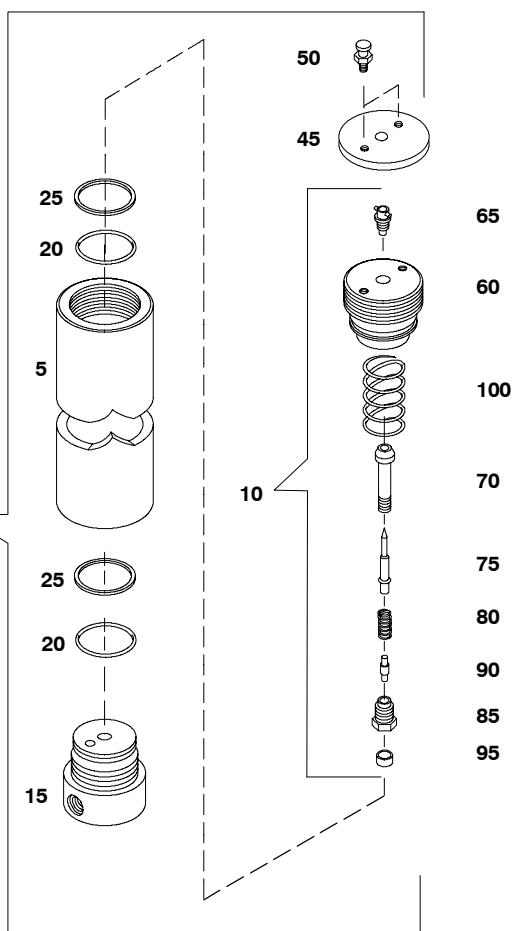

061685/04/98

 Wartungssätze  
 Maintenance kits  
 Kits d'entretien

**Baugruppe** 061685-EU  
**Assembly** 061685-EU  
**Assemblage** 061685-EU

**Filterbehälter kpl.**  
**Filter housing assy.**  
**Corps du filtre cpl.**
**TM320-18c**

Klasse/ Class/ Classe			Pos.	Bestell-Nr. Part No. No. de cde.	Anz. Qty. Qté.	Benennung	Designation	Dénomination
a	b	c						
			5	*	1	Behältergehäuse	filter housing	corps de filtre
			10	*	1	Behälterdeckel kpl.	filter top	couvercle de filtre
			15	*	1	Behälterboden	filter base part	fond de filtre
X			20	N4736	2	Stützring	back-up ring	bague d'appui
X			25	N4735	2	O-Ring	o-ring	joint torique
			30	78528	1	Fabrikschild	ident. plate	plaque d'identification
			35	N3334	1	Niete	semitubular rivet	rivet semi-tubulaire
			40	N3333	3	Blindniete	pop rivet	rivet aveugle
			45	60135	1	Schutzdeckel	protecting cover	couvercle-protecteur
			50	12293	2	Schraube	fastening screw	vis de fixation
			55	91025	1	Klebeschild	sticker	auto-collant
			60		1	Behälterverschraubung	Filter plug	bouchon de filtre
			65	59850	1	Buchse BNC	Socket BNC	Connecteur BNC
			70	59851	1	Bolzen	Bolt	Boulon
			75	59853	1	Stift	Pin	Goupille
			80	60062	1	Feder	Spring	Ressort
			85	59852	1	Schraube	Screw	Vis
			90	59854	1	Stift	Pin	Goupille
			95	59855	1	Mutter	Nut	Ecrou
			100	2181	1	Druckfeder	Pressure spring	Ressort

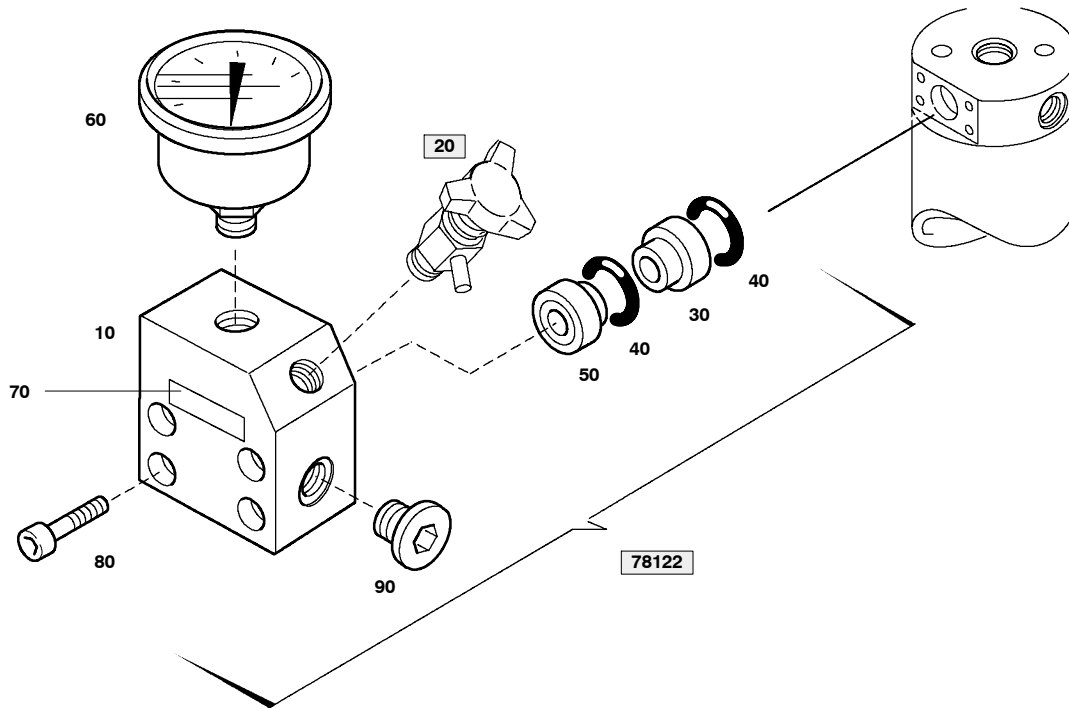
 Wartungssätze  
 Maintenance kits  
 Kits d'entretien

**Baugruppe 78122**    **Rückschlagventil**  
**Assembly 78122**    **Non-return valve**  
**Assemblage 78122**    **Soupape anti-retour**
**TM320-18d**

Klasse/ Class/ Classe			Pos.	Bestell-Nr. Part No. No. de cde.	Anz. Qty. Qté.	Benennung	Designation	Dénomination
a	b	c						
			10	78123	1	Ventilkörper	valve housing	corps de soupape
			20	011430	1	<b>Knebelschraube</b>	<b>condensate drain knob</b>	<b>robinet de purge</b>
			30	63843	1	Ventilsitz	non-return valve seat	siège de clapet anti-ret.
			40	N4178	2	O-Ring	o-ring	joint torique
			50	73767	1	Ventilkolben	valve piston	soupape de piston
			60	N17062	1	Manometer	gauge	manomètre
			70	64179	1	Schild	label	vignette
			80	N19538	4	Zylinderschraube	cylinder screw	vis à six pans creux
			90	N16394	1	Verschlussschraube	plug	bouchon

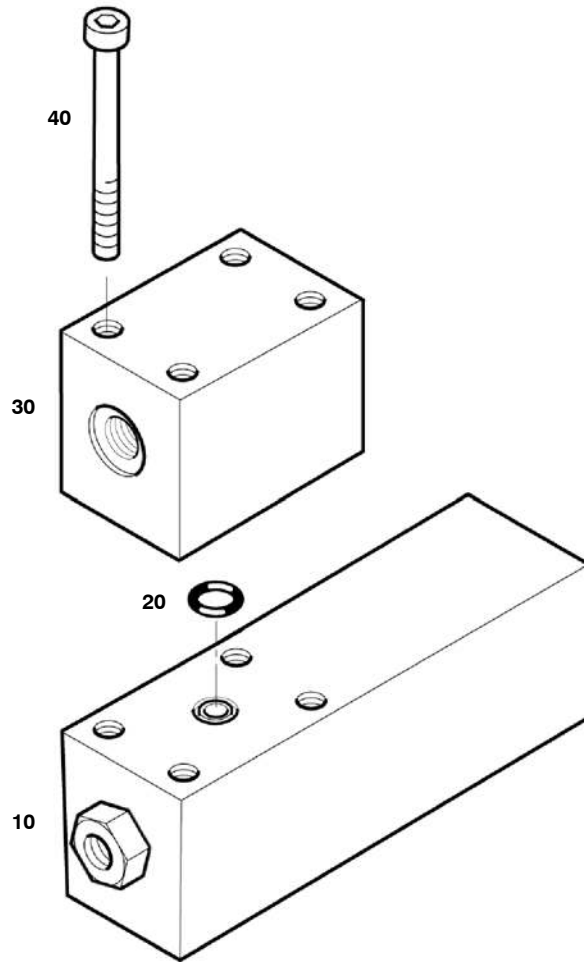

 Wartungssätze  
 Maintenance kits  
 Kits d'entretien

 Baugruppe 80751  
 Assembly 80751  
 Assemblage 80751

 Druckhalte-Rückschlagventil  
 Pressure maintaining and non-return valve  
 Soupape de maintien de pression anti-retour

**TM320-18e**

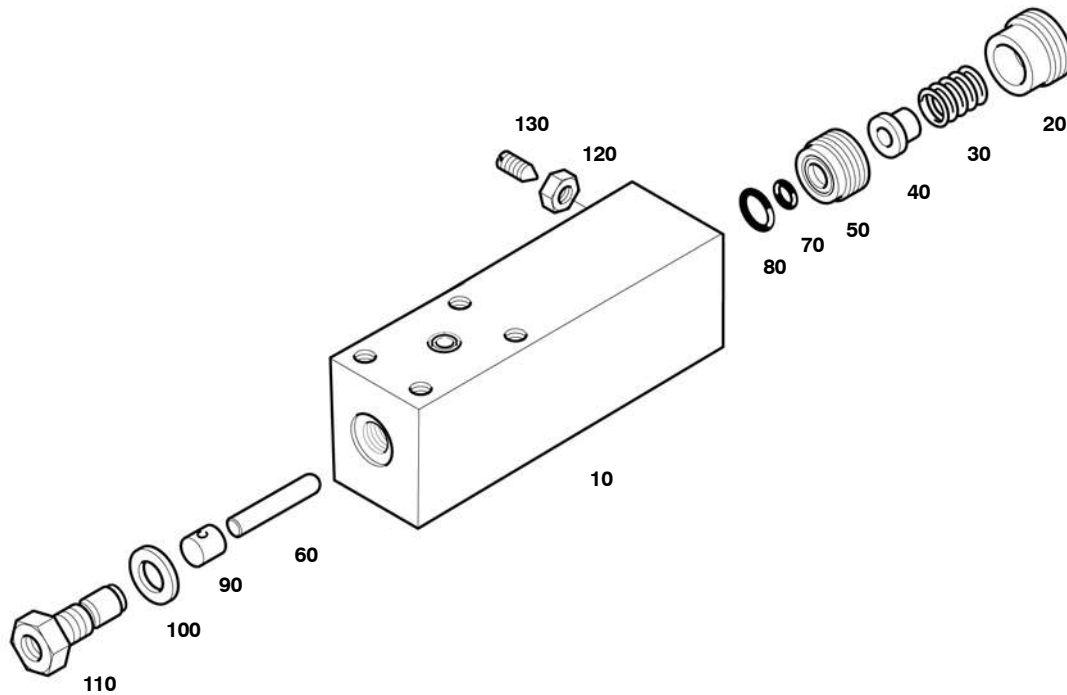
Klasse/ Class/ Classe			Pos.	Bestell-Nr. Part No. No. de cde.	Benennung	Designation	Dénomination
a	b	c					
			10	80719	Druckhalteventil	pressure maintaining valve	soupape de maintien de pression
			20	N3824	O-Ring	o-ring	joint torique
			30	80763	Rückschlagventil	non-return valve	soupape anti-retour
			40	N19538	Zylinderschraube	screw	vis

 Wartungssätze  
 Maintenance kits  
 Kits d'entretien

 Baugruppe 80719  
 Assembly 80719  
 Assemblage 80719

 Druckhalteventil  
 Pressure maintaining valve  
 Soupape de maintien de pression

**TM320-18f**

Klasse/ Class/ Classe			Pos.	Bestell-Nr. Part No. No. de cde.	Anz. Qty. Qté.	Benennung	Designation	Dénomination
a	b	c						
			10	80720	1	Ventilkörper	valve housing	corps de soupape
			20	57935	1	Einstellschraube	adjusting screw	vis d'ajustage
			30	2623	1	Druckfeder	spring	ressort de pression
			40	57762	1	Aufnahme	spring seat	siège de ressort
			50	78536	1	Aufnahme	seat	siège
			60	77245	1	Zylinderstift	cylinder stud	goupille cylindrique
			70	N25503	1	O-Ring	o-ring	joint torique
			80	N24927	1	O-Ring	o-ring	joint torique
			90	78688	1	Ventilkolben	valve piston	piston
			100	N4602	1	USIT-Ring	usit-ring	joint usit
			110	63841	1	Ventilsitz	valve seat	siège de soupape
			120	N3837	1	Sechskantmutter	hexagon nut self-locking	écrou hexagonal auto-freinant
			130	N4465	1	Gewindestift	set screw	goujon fileté



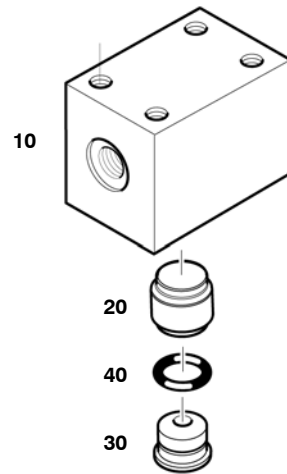

 Wartungssätze  
 Maintenance kits  
 Kits d'entretien

 Baugruppe 80763  
 Assembly 80763  
 Assemblage 80763

 Rückschlagventil  
 Non-return valve  
 Soupape anti-retour

**TM320-18g**

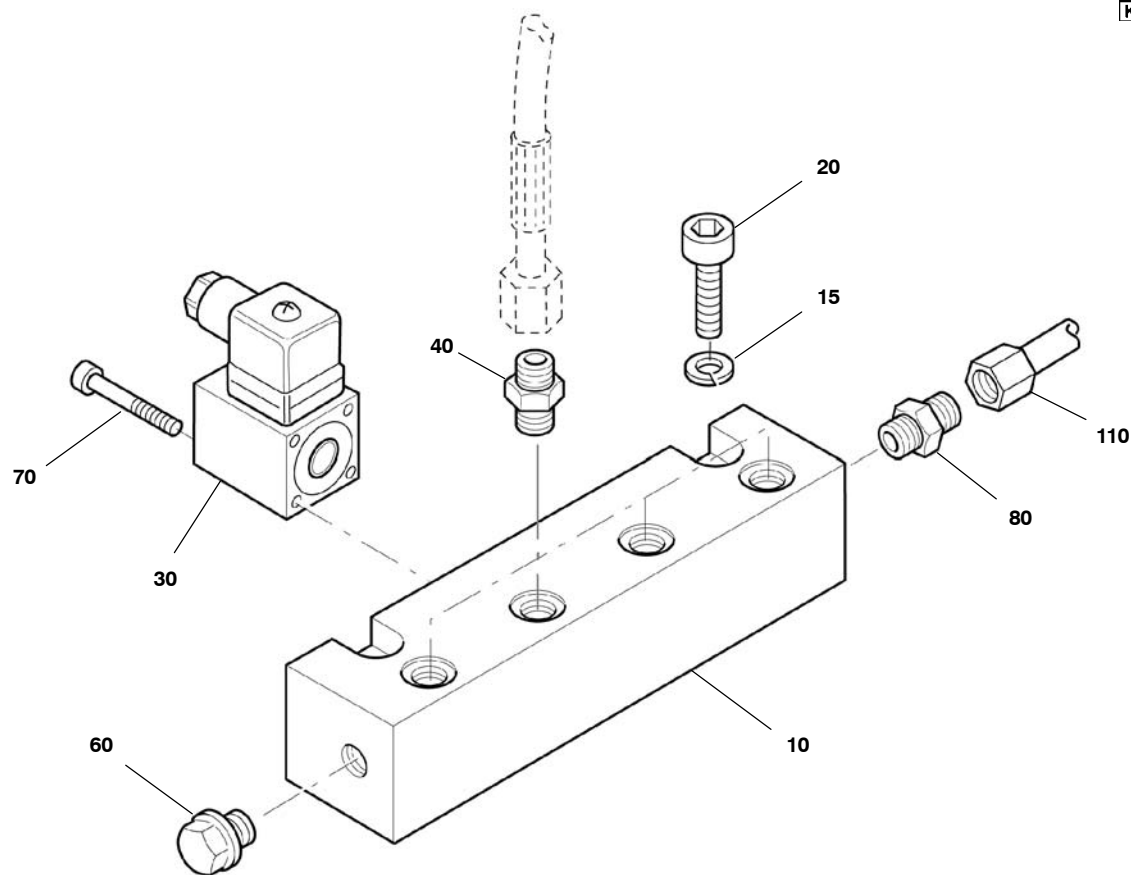
Klasse/ Class/ Classe			Pos.	Bestell-Nr. Part No. No. de cde.	Anz. Qty. Qté.	Benennung	Designation	Dénomination
a	b	c						
			10	80746	1	Ventilkörper	valve housing	corps de soupape
			20	73767	1	Ventilkolben	valve piston	soupape de piston
			30	80716	1	Ventilsitz	valve seat	siège de soupape
			40	N24927	1	O-Ring	o-ring	joint torique

 Wartungssätze  
 Maintenance sets  
 Kits d'entretien

**Baugruppe** 80626  
**Assembly** 80626  
**Assemblage** 80626

**Fülleiste**  
**Filling device**  
**Listeau de remplissage**
**TM320-19**

Klasse/ Class/ Classe			Pos.	Bestell-Nr. Part No. No. de cde.	Benennung	Designation	Dénomination
a	b	c					
			10	80448-01	Sammelleiste	distributor	listeau collecteur
			15	N108	Federring	spring washer	rondelle-ressort
			20	N19552	Zylinderschraube	allen screw	vis à six pans creux
			30	N23001	Druckschalter	pressure switch	manostat
			40	78803	UNIMAM-Verschraubung	UNIMAM connector	raccord UNIMAM
			60	N4570	Verschlussschraube	plug	bouchon fileté
			70	N821	Zylinderschraube	allen screw	vis à six pans creux
			80	N20211	G-Einschraubstutzen	straight male stud	raccord droit mâle
			110	80702	Verbindungsleitung kpl.	connecting tube assy.	tuyau cpl.

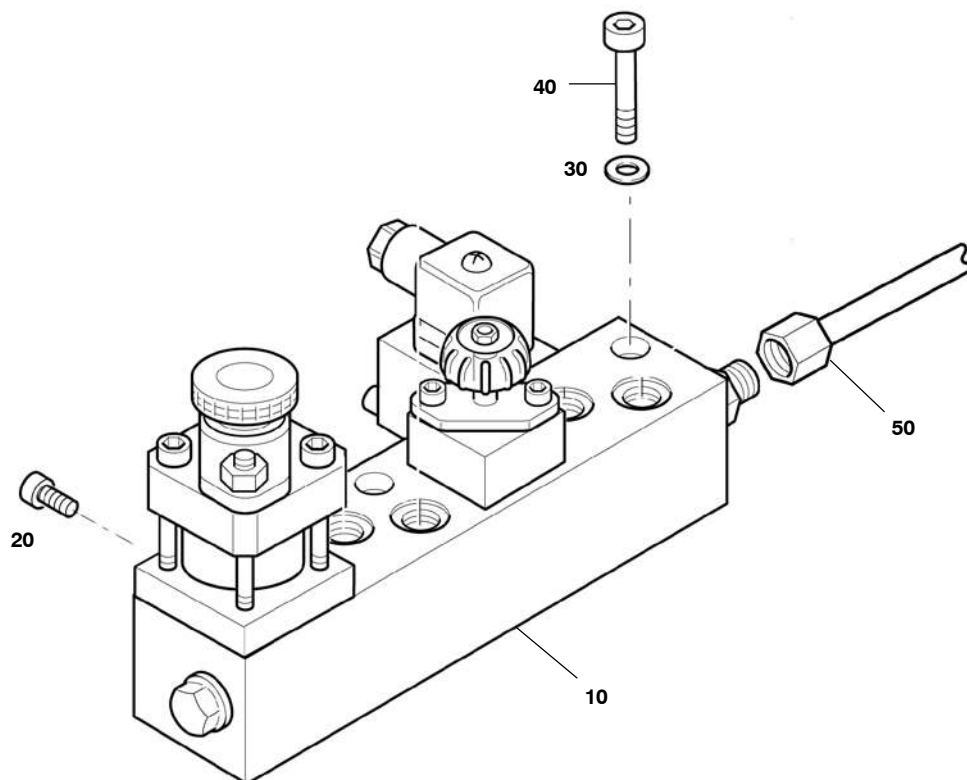
 Wartungssätze  
 Maintenance sets  
 Kits d'entretien

**Baugruppe** 80626-01 **Umschalteinrichtung**  
**Assembly** 80626-01 **Switch-over device**  
**Assemblage** 80626-01 **Sélecteur**
**TM320-20**

Klasse/ Class/ Classe			Pos.	Bestell-Nr. Part No. No. de cde.	Benennung	Designation	Dénomination
a	b	c					
			10	80617	Umschaltleiste kpl.	switch-over device assy	l'istean de sélection cpl.
			20	N19556	Zylinderschraube	allen screw	vis allen
			30	N108	Federring	spring washer	rondelle-ressort
			40	N821	Zylinderschraube	allen screw	vis allen
			50	80702	Verbindungsleitung kpl.	connecting line assy.	conduite de connexion cpl.

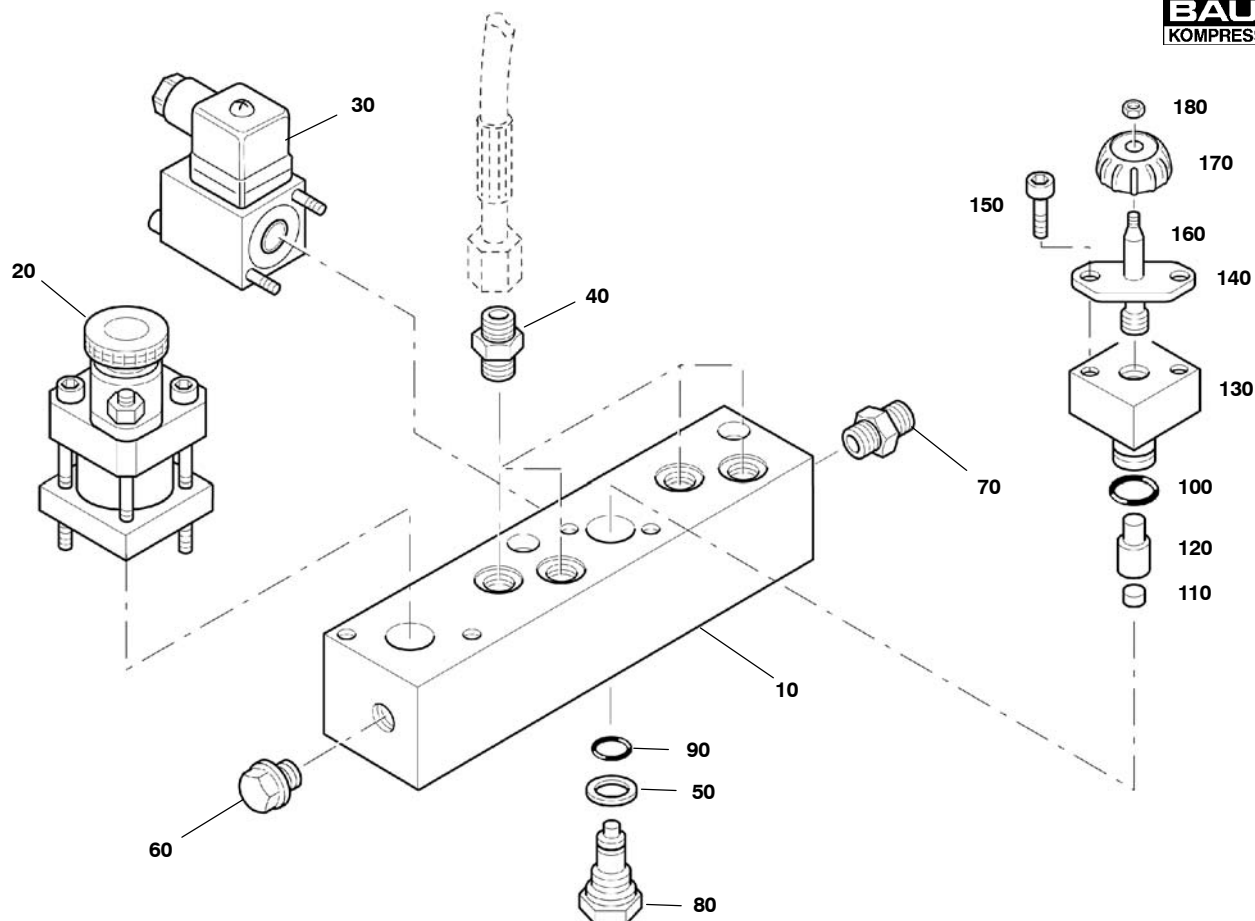
 Wartungssätze  
 Maintenance sets  
 Kits d'entretien

**Baugruppe** 80617  
**Assembly** 80617  
**Assemblage** 80617

**Umschaltleiste**  
**Switch-over manifold**  
**Rampe de sélection**
**TM320-20a**

Klasse/ Class/ Classe			Pos.	Bestell-Nr. Part No. No. de cde.	Benennung	Designation	Dénomination
a	b	c					
			10	80611	Umschaltleiste	manifold	rampe
			<b>20</b>	<b>059410</b>	<b>Sicherheitsventil</b>	<b>safety valve</b>	<b>soupape de sûreté</b>
			30	N23001	Druckschalter	pressure switch	manostat
			40	65363	Unimam-Verschraubung	Unimam connector	raccord Unimam
			50	N4602	USIT-Ring	USIT ring	joint USIT
			60	N52	Verschlußschraube	plug	bouchon
			70	N20195	GE-Einschraubverschraubung	male connector	raccord
			80	74530	Ventilsitz	valve seat	siège de soupape
			90	N16591	O-Ring	o-ring	joint torique
			100	N17654	O-Ring	o-ring	joint torique
			110	N17080	Dichtung	gasket	joint
			120	074860	Dichtsitz	seal	siège d'étanchéité
			130	80628	Flansch	flange	bride
			140	74390	Blech	sheet metal	plaque de fixation
			150	N19550	Zylinderschraube	allen screw	vis allen
			160	75316	Spindel	spindle	spindle
			170	N1865	Drehknopf	knob	molette
			180	N2488	Mutter	nut	écrou

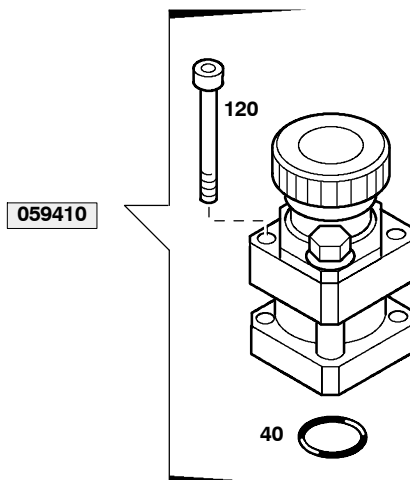

Wartungssätze  
 Maintenance sets  
 Kits d'entretien

**Baugruppe** 059410  
**Assembly** 059410  
**Assemblage** 059410

**Sicherheitsventil**  
**Safety valve**  
**Soupape de sûreté**

# TM320-20b

Klasse/ Class/ Classe			Pos.	Bestell-Nr. Part No. No. de cde.	Benennung	Designation	Dénomination
a	b	c					
			40	N4882	O-Ring	o-ring	joint torique
			120	N19555	Zylinderschraube	screw	vis

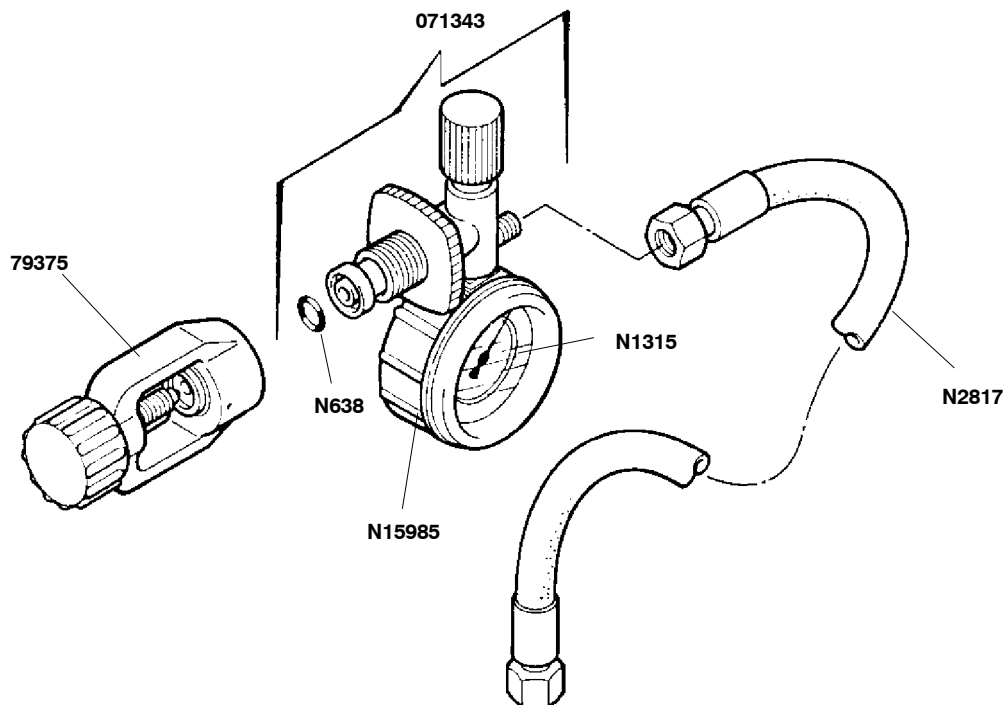

 Wartungssätze  
 Maintenance sets  
 Kits d'entretien

**Bildtafel**
**014355**
**Fülleinrichtung 200 bar**
**Figure**
**014355**
**Filling device 200 bar**
**Planche**
**014355**
**Dispositif de remplissage 200 bar**
**TM320-21**

Klasse/ Class/ Classe			Bestell-Nr. Part No.	Benennung	Designation	Dénomination
a	b	c	No. de cde.			
			071343	Füllventil	Filling valve	Vanne de remplissage
			65594	Bänderole	Ribbon	bandelette
			79375	Internat. Füllanschlußbügel	International connection	Raccord international
			N2817	Füllschlauch	Filling hose	Tuyau de remplissage

Ersatzteile/spares/pièces détachées:

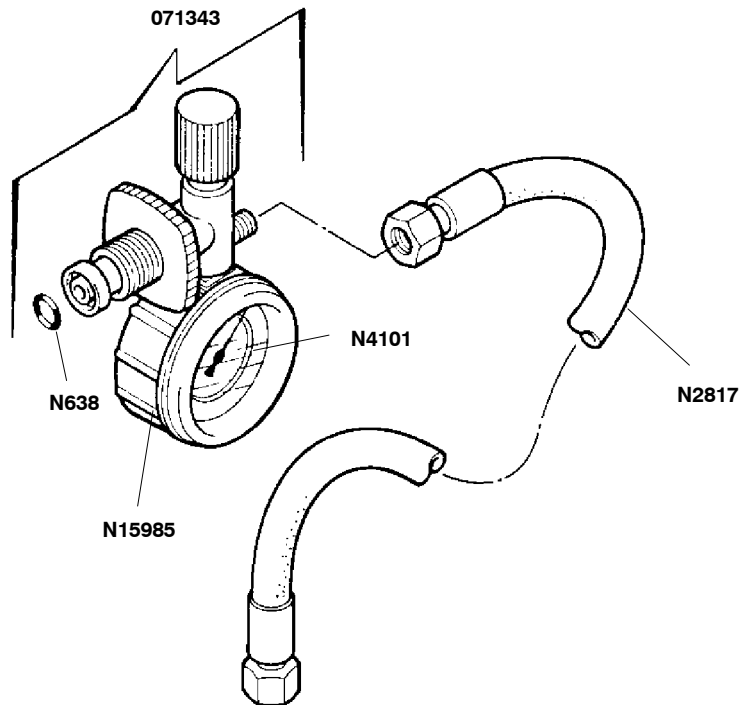
	X		072349	Reparatursatz für Füllventil	Repair kit for filling valve	Kit de rép. p. vanne de remplissage
			N638	O-Ring	O-ring	Joint torique
			N1315	Manometer	Pressure gauge	Manomètre
			N15985	Schutzkappe	Protection cap	Chapeau de protection

 Wartungssätze  
 Maintenance sets  
 Kits d'entretien

**Bildtafel**  
**Figure**  
**Planche**

 014356  
 014356  
 014356

**Fülleinrichtung 300 bar**  
**Filling device 300 bar**  
**Dispositif de remplissage 300 bar**
**TM320-22**

Klasse/ Class/ Classe			Bestell-Nr. Part No.	Benennung	Designation	Dénomination
a	b	c	No. de cde.			
			071344	Füllventil	Filling valve	Vanne de remplissage
			65595	Bänderole	Ribbon	bandelette
			N2817	Füllschlauch	Filling hose	Tuyau de remplissage

Ersatzteile/spares/pièces détachées:

	X		072349	Reparatursatz für Füllventil	Repair kit for filling valve	Kit de rép. p. vanne de remplissage
			N638	O-Ring	O-ring	Joint torique
			N4101	Manometer	Pressure gauge	Manomètre
			N15985	Schutzkappe	Protection cap	Chapeau de protection

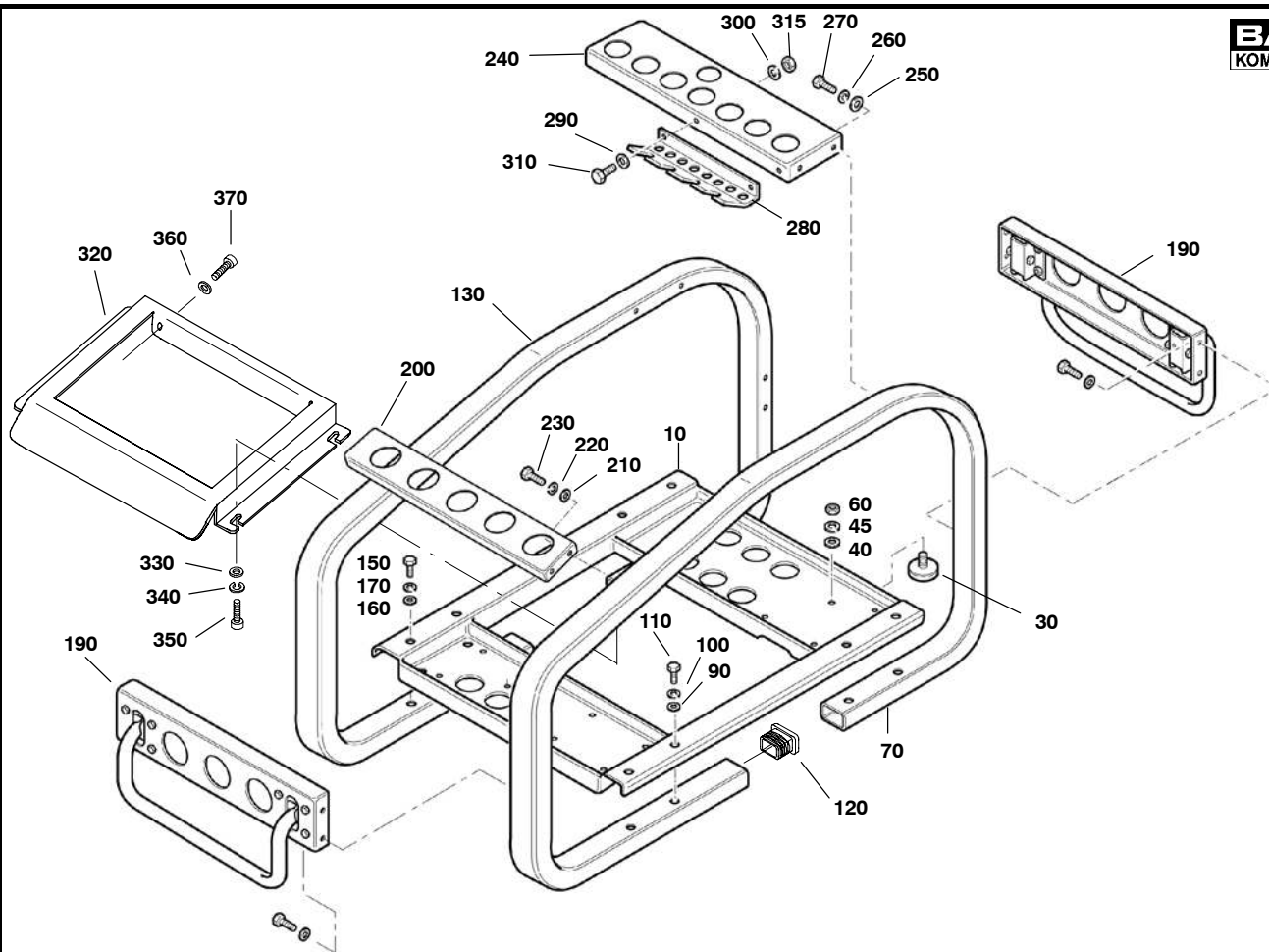

 Wartungssätze  
 Maintenance sets  
 Kits d'entretien

**Baugruppe** 79863  
**Assembly** 79863  
**Assemblage** 79863

**Rahmen**  
**Frame**  
**Cadre**

# TM320-23

Klasse/ Class/ Classe			Pos.	Bestell-Nr. Part No. No. de cde.	Benennung	Designation	Dénomination
a	b	c					
			10	79863-02	Rahmen -RAL 7024	frame -RAL 7024	cadre -RAL 7024
			30	N26561	Schwingmetall	vibration isolator	silent-bloc
			40	N16	Scheibe	washer	rondelle
			45	N8999	Federring	lock washer	rondelle élastique
			60	N644	Sechskantmutter	hexagon nut self-locking	ecrou hexagonal auto-freinant
			70	79863-01	Rahmen -RAL 9006	frame -RAL 9006	cadre -RAL 9006
			90	N58	Scheibe	washer	rondelle
			100	N108	Federring	spring washer	rondelle-ressort
			110	N19506	Sechskantschraube	screw	vis
			120	N26426	Verschlußstopfen	plug	bouchon
			130	79863-03	Rahmen -RAL 9006	frame -RAL 9006	cadre -RAL 9006
			150	N19506	Sechskantschraube	screw	vis
			160	N58	Scheibe	washer	rondelle
			170	N108	Federring	spring washer	rondelle-ressort
			<b>190</b>	<b>79959</b>	<b>Griff kpl.</b>	<b>handle assy.</b>	<b>poignée cpl.</b>
			200	80009	Halterung	bracket	fixation
			210	N58	Scheibe	washer	rondelle
			220	N108	Federring	spring washer	rondelle-ressort
			230	N19548	Zylinderschraube	allen screw	vis à six pans creux
			240	80009-01	Halterung	bracket	fixation
			250	N58	Scheibe	washer	rondelle
			260	N108	Federring	spring washer	rondelle-ressort
			270	N19548	Zylinderschraube	allen screw	vis à six pans creux
			280	80009-02	Halterung	bracket	fixation
			290	N102	Scheibe	washer	rondelle
			300	N100	Federring	spring washer	rondelle-ressort
			310	N19535	Zylinderschraube	allen screw	vis à six pans creux
			320	79938	Halterung	bracket	fixation
			330	N58	Scheibe	washer	rondelle
			340	N108	Federring	spring washer	rondelle-ressort
			350	N19548	Zylinderschraube	allen screw	vis à six pans creux
			360	N58	Scheibe	washer	rondelle
			370	N19548	Zylinderschraube	allen screw	vis à six pans creux



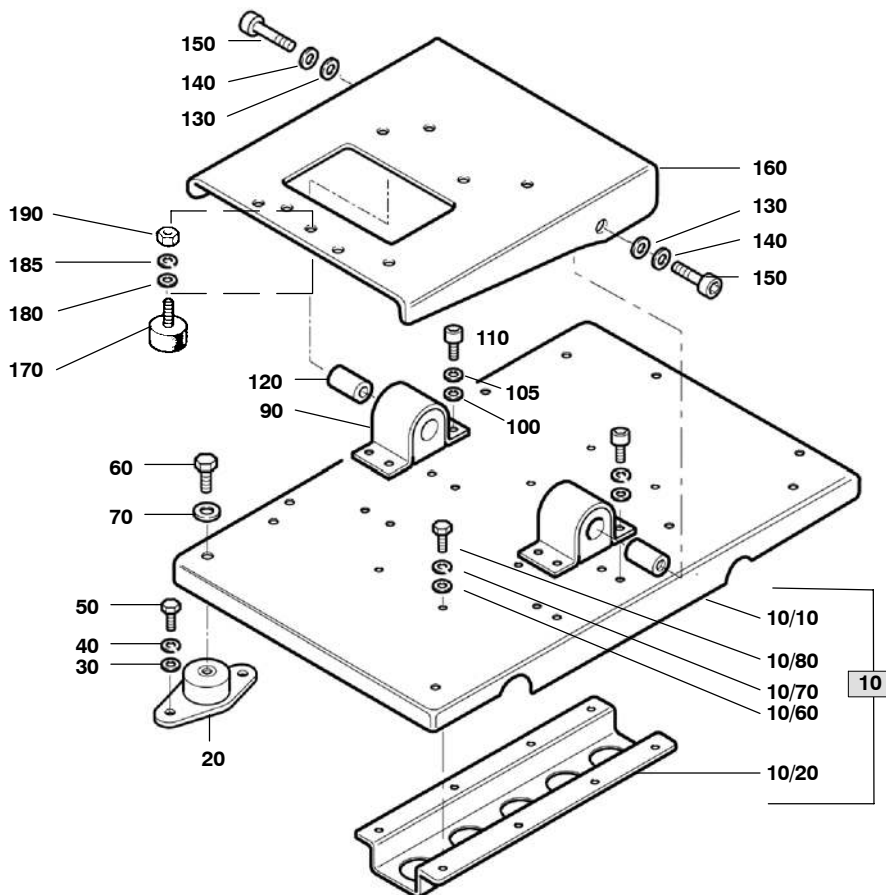

 Wartungssätze  
 Maintenance sets  
 Kits d'entretien

**Bildtafel**  
**Figure**  
**Planche**
**80080**  
**80080**  
**80080**
**Schwingrahmen kpl.**  
**Antivibration frame**  
**Châssis antivibration cpl.**
**TM320-23a**

Klasse/ Class/ Classe			Pos.	Bestell-Nr. Part No. No. de cde.	Benennung	Designation	Dénomination
a	b	c					
			<b>10</b>	<b>80078</b>	<b>Schwingrahmen kpl.</b>	<b>anti-vibration frame</b>	<b>châssis antivibration</b>
			20	N26164	Schwingmetall	shock mount	amortisseur
			30	N58	Scheibe	washer	rondelle
			40	N108	Federring	lock washer	rondelle-ressort
			50	N19458	Sechskantschraube	hex screw	vis six pans
			60	N891	Sechskantschraube	hex screw	vis six pans
			70	N1594	Scheibe	washer	rondelle
			90	N26577	Schwingmetall	shock mount	amortisseur
			100	N58	Scheibe	washer	rondelle
			105	N108	Federring	lock washer	rondelle-ressort
			110	N19548	Zylinderschraube	allen screw	vis allen
			120	79862	Bolzen	pin	axe
			130	N58	Scheibe	washer	rondelle
			140	N108	Federring	lock washer	rondelle-ressort
			150	N19506	Sechskantschraube	hex screw	vis six pans
			160	79859-03	Motorwippe	hinged motor plate	bascule du moteur
			170	N26414	Schwingmetall	shock mount	amortisseur
			180	N4665	Scheibe	washer	rondelle
			185	N3313	Federring	lock washer	rondelle-ressort
			190	N1042	Sechskantmutter	hex. nut	écrou
			200	80550	Kunststoffrohr	plastic tube	tuyau en plastique
			210	N22359	Schnappschelle	clamp	collier

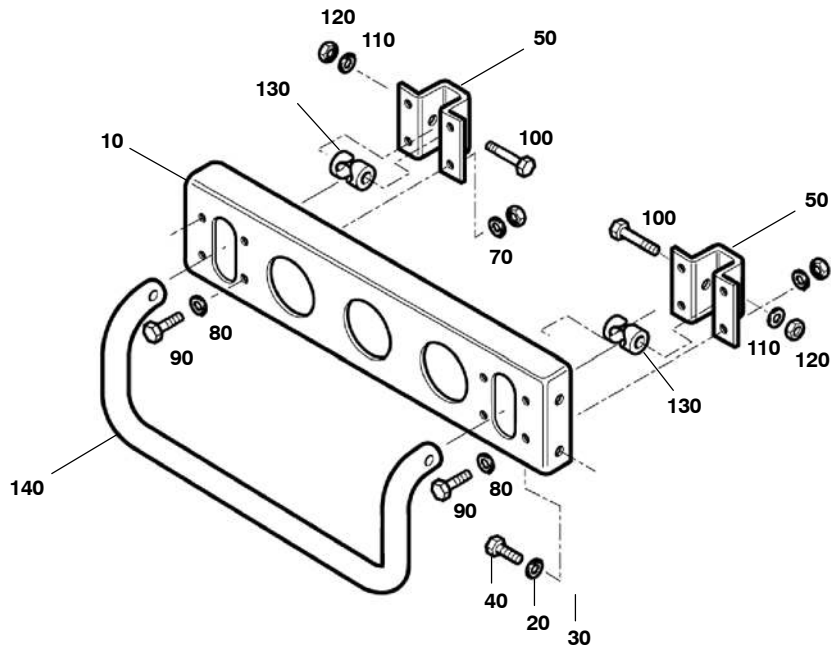
			10/10	79854-01	Schwingrahmen	frame	châssis amortisseur
			10/20	79854-02	Versteifung	support	renfort
			10/60	N58	Scheibe	washer	rondelle
			10/70	N108	Federring	lock washer	rondelle-ressort
			10/80	N19548	Zylinderschraube	allen screw	vis allen





 Wartungssätze  
 Maintenance sets  
 Kits d'entretien

**Bildtafel**    79959    **Griff kpl.**  
**Figure**        79959    **Handle assy.**  
**Planche**       79959    **Poignée cpl.**

**TM320-23b**

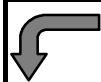
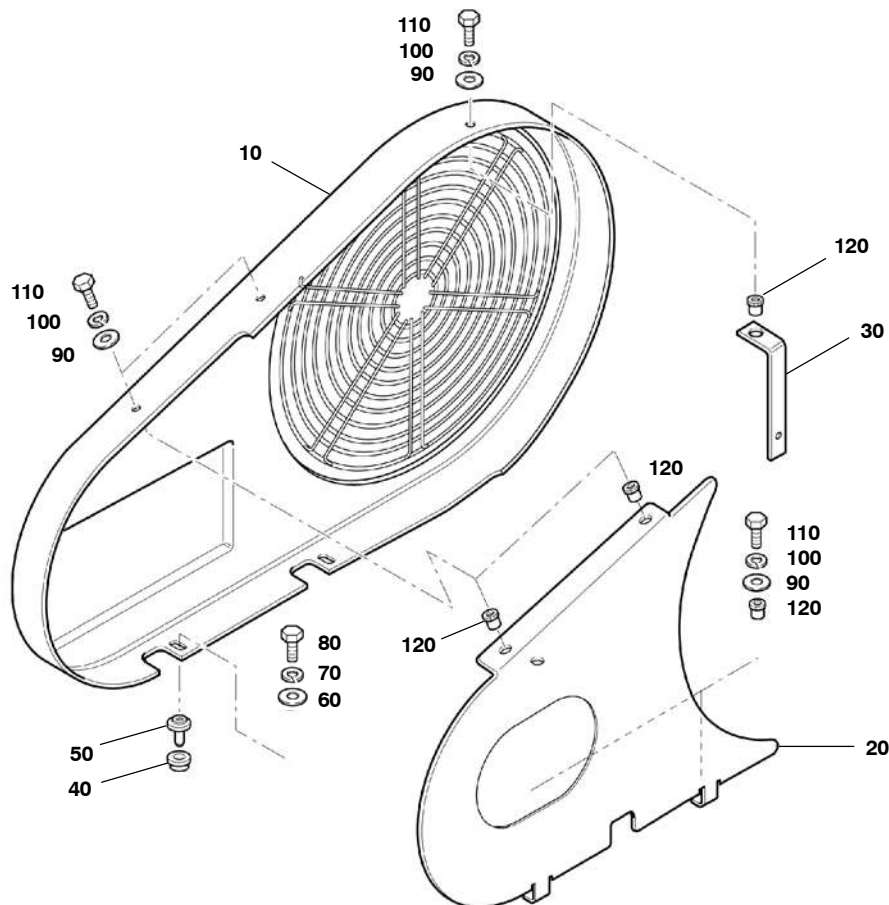
Klasse/ Class/ Classe			Pos.	Bestell-Nr. Part No. No. de cde.	Benennung	Designation	Dénomination
a	b	c					
			10	79954	Griffhalterung	handle bracket	fixation de poignée
			20	N108	Federring	lock washer	rondelle-ressort
			30	N58	Scheibe	washer	rondelle
			40	N19548	Zylinderschraube	allen screw	vis allen
			50	79955	Griff-Drehgelenk	hinge	charnière
			70	N108	Federring	lock washer	rondelle-ressort
			80	N58	Scheibe	washer	rondelle
			90	N19548	Zylinderschraube	allen screw	vis allen
			100	N19555	Zylinderschraube	allen screw	vis allen
			110	N58	Scheibe	washer	rondelle
			120	N370	Sechskantmutter	hex nut	écrou
			130	N26381	Sattelscheibe	plastic spacer	entretoise en plastique
			140	79956	Griffrohr	handle bar	tube de poignée

 Wartungssätze  
 Maintenance sets  
 Kits d'entretien

**Bildtafel**  
**Figure**  
**Planche**
**80584**  
**80584**  
**80584**
**Riemenschutz kpl.**  
**V-belt cover assy.**  
**Carter de courroie cpl.**
**TM320-23c**

Klasse/ Class/ Classe			Pos.	Bestell-Nr. Part No. No. de cde.	Benennung	Designation	Dénomination
a	b	c					
			10	79978-S01	Riemenschutz m Gitter	v-belt cover with grid	carter de courroie avec grille
			20	79977	Riemenschutz innen	v-belt cover, inner	carter de courroie, intérieur
			30	80271	Halterung	bracket	fixation
			40	N26454	Buchse	bushing	manchon
			50	80501	Stift	pin	goupille
			60	N2863	Scheibe, groß	washer, large	rondelle, large
			65	N2949	Scheibe	washer	rondelle
			70	N635	Federring	lock washer	rondelle-ressort
			80	N3989	Sechskantschraube	hex screw	vis
			90	N2863	Scheibe	washer	rondelle
			100	N100	Federring	lock washer	rondelle-ressort
			110	N19535	Zylinderschraube	allen screw	vis allen
			120	N26455	Mutter, Silentblock	nut, shock mount	écrou, silentbloc

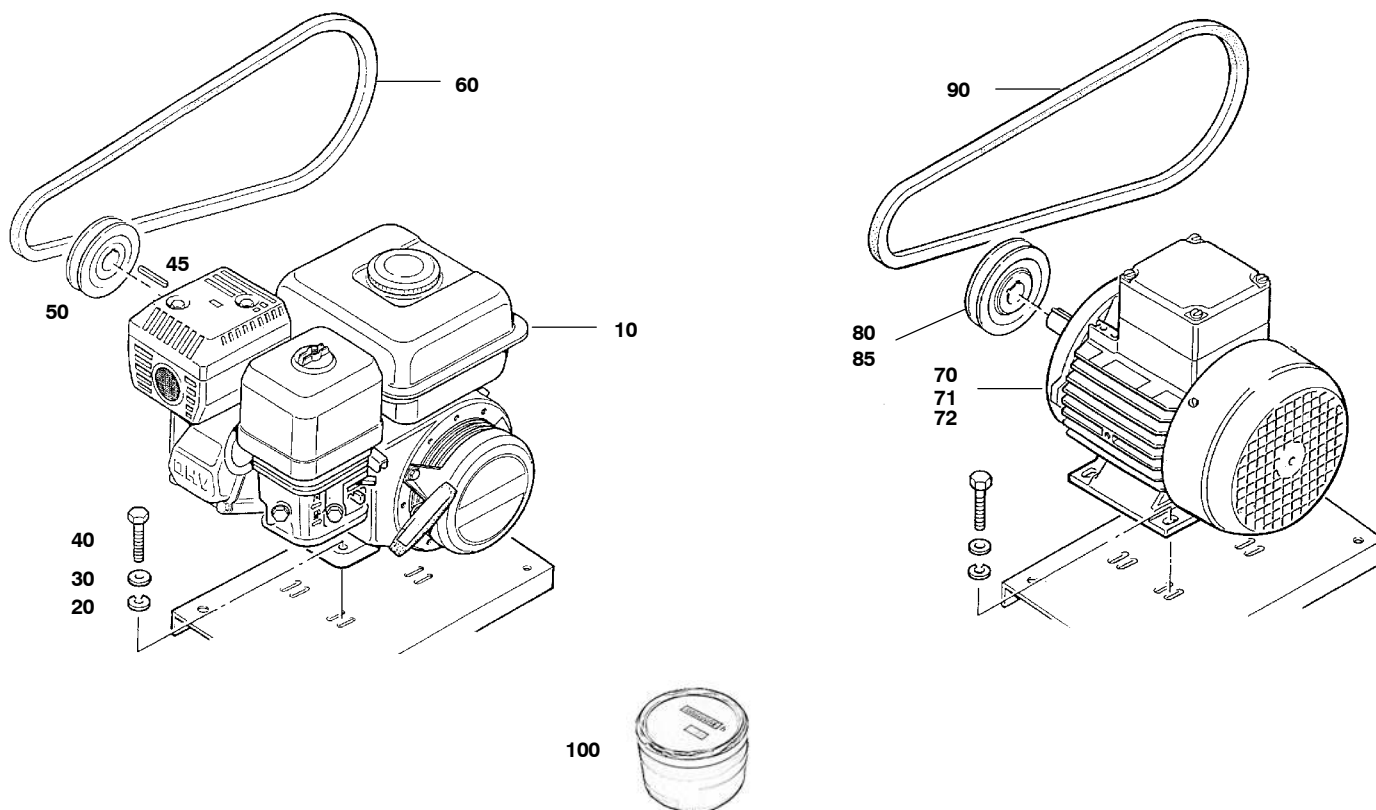
 Wartungssätze  
 Maintenance sets  
 Kits d'entretien

**Baugruppe** 80444  
**Assembly** 80444  
**Assemblage** 80444

**Antriebsmotoren und Zubehör**  
**Driving motors and accessories**  
**Moteurs d'entraînement et accessoires**
**TM320-24**

Klasse/ Class/ Classe			Pos.	Bestell-Nr. Part No. No. de cde.	Benennung	Designation	Dénomination
a	b	c					
			10	N26136	Benzinmotor	petrol engine	moteur à essence
			20	N58	Scheibe	washer	rondelle
			30	N108	Federring	spring washer	rondelle-ressort
			40	N19462	Sechskantschraube	hex. screw	vis six pans
			45	80741	Paßfeder	feather key	clavette
			50	80276	Keilriemenscheibe (D=180 mm)	v-belt pulley (D=180 mm)	poulie (D=180 mm)
			60	N2598	Keilriemen (L=1932 mm)	v-belt (L=1932 mm)	courroie trapézoïdale (L=1932 mm)
			70	N25462	Drehstrommotor 400 V, 50 Hz	3 phase motor 400 V, 50 Hz	moteur triphasé 400 V, 50 Hz
			71	N26680	Drehstrommotor 200 V, 50/60 Hz	3 phase motor 200 V, 50/60 Hz	moteur triphasé 200 V, 50/60 Hz
			72	N25532	Drehstrommotor 220 V, 50 Hz	3 phase motor 220 V, 50 Hz	moteur triphasé 220 V, 50 Hz
			80	N18496	Keilriemenscheibe (D=224 mm)	v-belt pulley (D=224 mm)	poulie (D=224 mm)
			85	N26327	Keilriemenscheibe (D=190 mm)	v-belt pulley (D=190 mm)	poulie (D=190 mm)
			90	N18841	Keilriemen (L=1957 mm)	V-belt (L=1957 mm)	courroie (L=1957 mm)
			100	N3465	Betriebsstundenzähler	time totalizer	compteur horaire

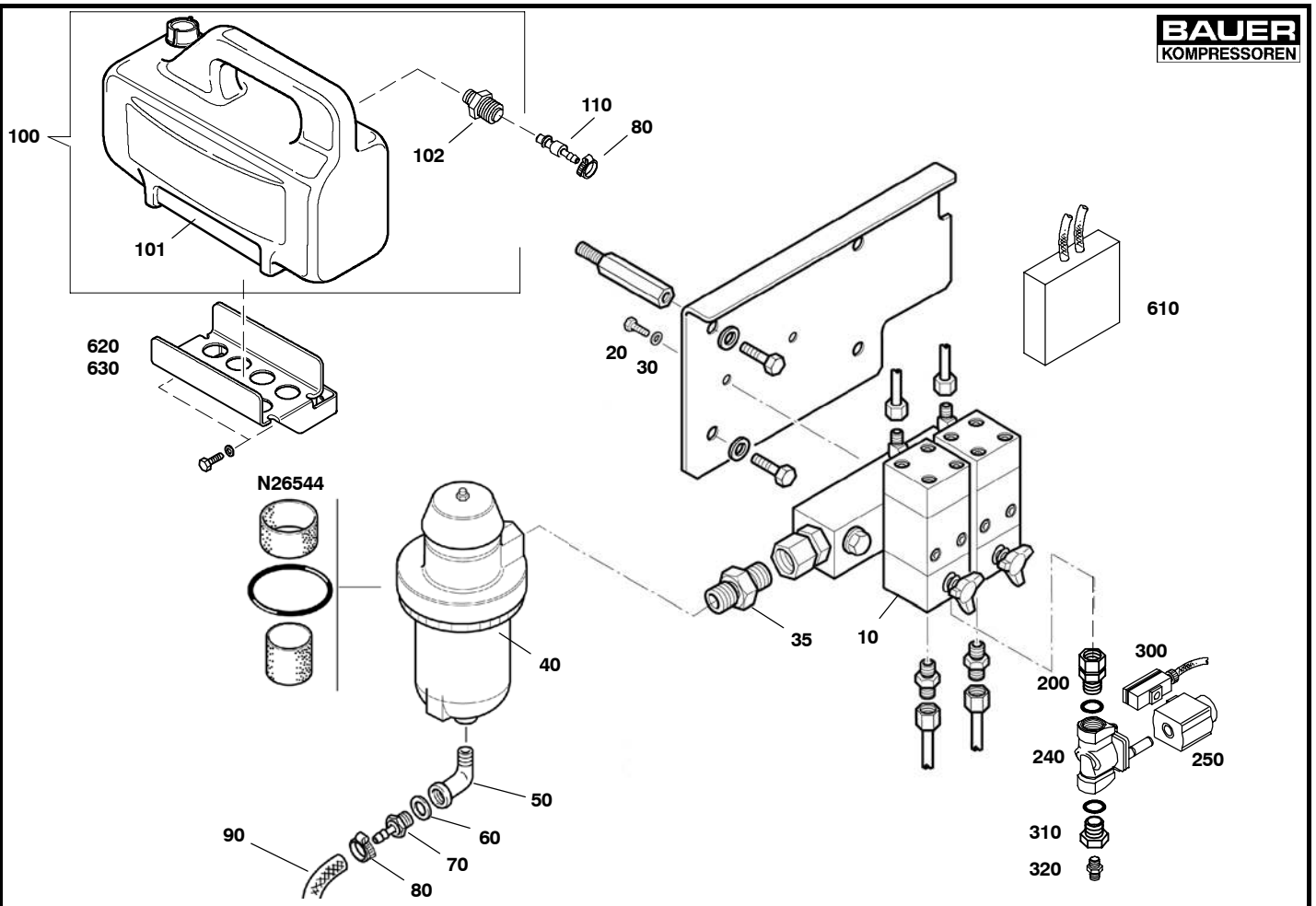

**Wartungssätze**  
**Maintenance sets**  
**Kits d'entretien**

**Baugruppe** 80589  
**Assembly** 80589  
**Assemblage** 80589

**Kondensatablaufautomatik kpl. (Zusatzausstattung)**  
**Automatic condensate drain (optional extra)**  
**Purge automatique des condensats (optionnelle)**

# TM320-25

Klasse/ Class/ Classe			Pos.	Bestell-Nr. Part No. No. de cde.	Benennung	Designation	Dénomination
a	b	c					
			<b>10</b>	<b>80571</b>	<b>Kondensat-Ablaufautomatik</b>	<b>automatic condensate drain</b>	<b>purge automatique des condensats</b>
			20	N19534	Zylinderschraube	allen screw	vis allen
			30	N100	Federring	spring washer	rondelle-ressort
			35	N20098	G-Einschraubstutzen	straight male connector	raccord droit mâle
			40	80574	Schalldämpfer-Filter	silencer-filter	silencieux-filtre
			40a	N26544	Wartungssatz zu 40	maintenance kit for 40	kit d'entretien pour 40
			50	N1855	Winkel	elbow	coude
			60	N293	Dichtring	gasket	joint
			70	N23873	Schlauchtülle	hose nozzle	raccord de tuyau
			80	N7454	Schlauchschelle	hose clamp	collier de serrage
			90	N19939	Schlauch	PVC hose	PVC tuyau
			<b>100</b>	<b>81672</b>	<b>Kondensatbehälter kpl.</b>	<b>condensate collector assy.</b>	<b>réservoir à condensats cpl.</b>
			101	81089-02	Kondensatbehälter	condensate collector	réservoir à condensats
			102	N17179	Kupplung	coupling	raccord
			110	N24631	Stecker m. Schlauchtülle	plug	raccord
			200	N4502	G-Einschraubstutzen	straight male connector	raccord droit mâle
			240	N27099	Magnetventil	2/2-way solenoid valve	électrovanne 2/2 voies
			250	N27100	Magnetspule	magnetic coil	bobine
			300	N22584*	Taktgeber	timer	minuterie
			310	N20112	Reduzierstutzen	fitting	raccord
			320	N20065	G-Einschraubstutzen	Straight male stud	raccord droit mâle
			330	N3609	Schneidring	cutting ring	rondelle de matrice
			340	N1049	Überwurfmutter	screw cap	écrou-chapeau
			350	N3618	Rohr	stainless steel tube 8x1	tuyau en acier inox 8x1
			360	N1049	Überwurfmutter	screw cap	écrou-chapeau
			370	N3609	Schneidring	cutting ring	rondelle de matrice
			380	N20152	Einst. W-Stutzen	adjustable W-coupling	raccord coudé orientable
			400	N20065	G-Einschraubstutzen	Straight male stud	raccord droit mâle
			410	N3609	Schneidring	cutting ring	rondelle de matrice
			420	N1049	Überwurfmutter	screw cap	écrou-chapeau
			430	N3618	Rohr	stainless steel tube 8x1	tuyau en acier inox 8x1
			440	N1049	Überwurfmutter	screw cap	écrou-chapeau

\*\* Bei Bestellung Spannung und Frequenz angeben      Please specify voltage and frequency on order      Veuillez indiquer tension et fréquence à la commande

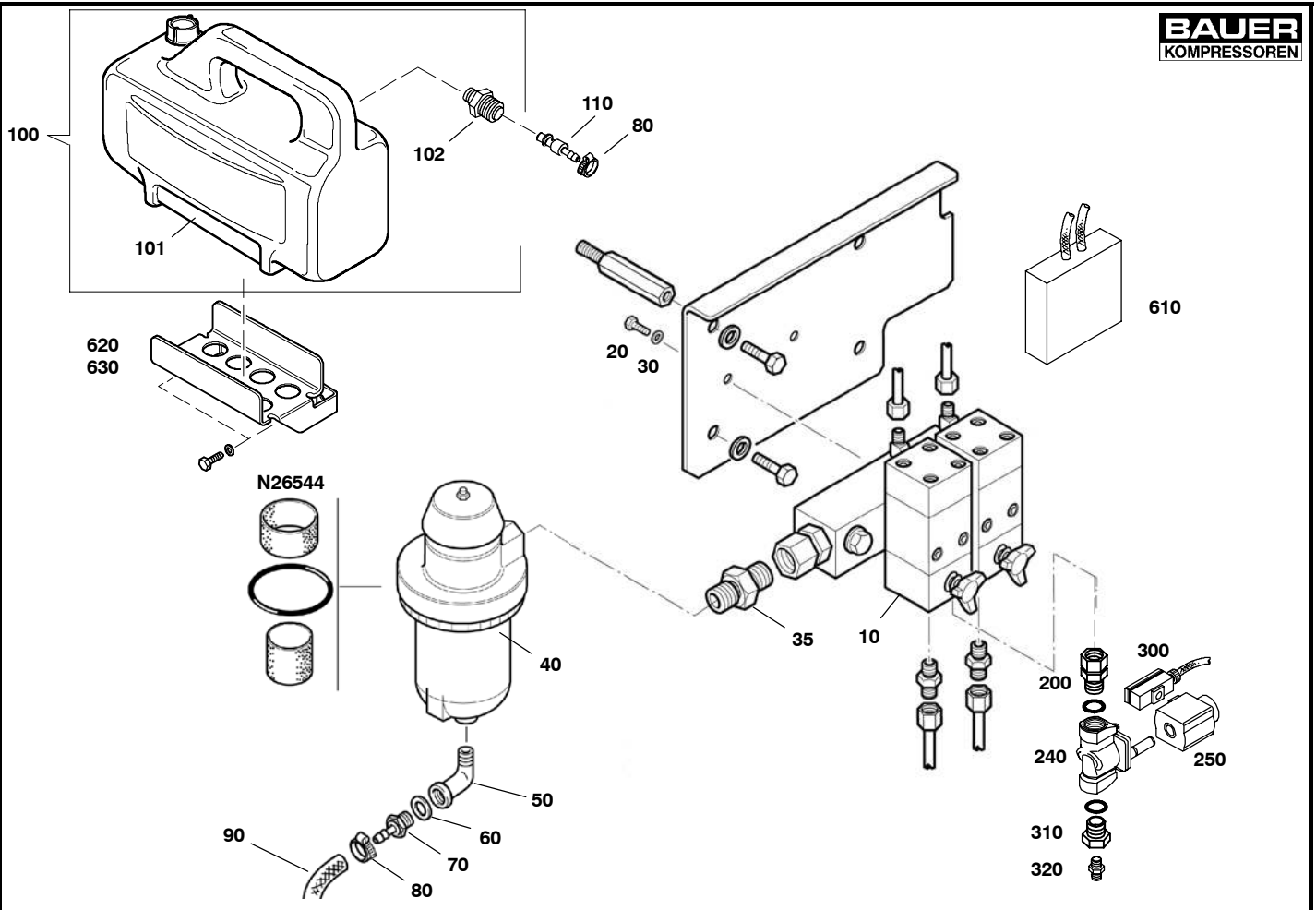



**Wartungssätze**  
 Maintenance sets  
 Kits d'entretien

**Baugruppe** 80589      **Kondensatablaufautomatik kpl. (Zusatzausstattung)**  
**Assembly** 80589      **Automatic condensate drain (optional extra)**  
**Assemblage** 80589      **Purge automatique des condensats (optionnelle)**

**TM320-25**

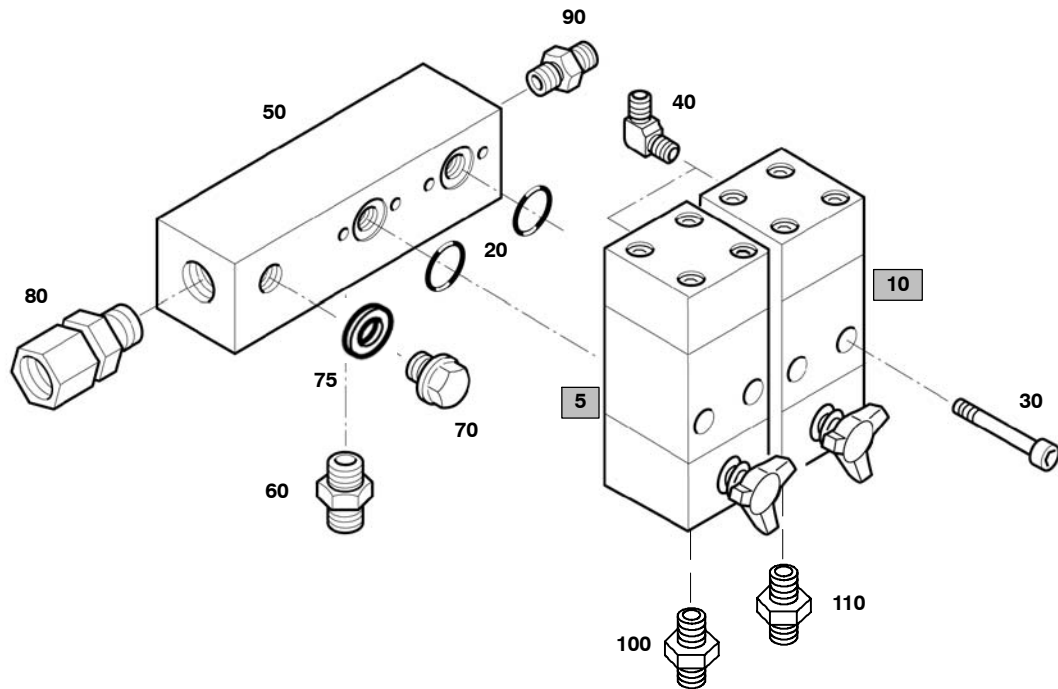
Klasse/ Class/ Classe			Pos.	Bestell-Nr. Part No. No. de cde.	Benennung	Designation	Dénomination
a	b	c					
			450	N3609	Schneidring	cutting ring	rondelle de matrice
			460	N20152	Einst. W-Stutzen	adjustable W-coupling	raccord coudé orientable
			470	N20287	G-Einschraubstutzen	union	raccord
			480	N3609	Schneidring	cutting ring	rondelle de matrice
			490	N3608	Überwurfmutter	screw cap	écrou-chapeau
			500	N3619	Rohr	stainless steel tube 8x1.5	tuyau en acier inox 8x1.5
			510	N3608	Überwurfmutter	screw cap	écrou-chapeau
			520	N3609	Schneidring	cutting ring	rondelle de matrice
			530	N20404	G-Einschraubstutzen	Screwed socket	raccord
			540	N3663	Schneidring	cutting ring 6L/S	rondelle de matrice
			550	N7430	Überwurfmutter	screw cap	écrou-chapeau
			560	N3616	Rohr	stainless steel tube 6x1	tuyau en acier inox 6x1
			570	N3663	Schneidring	cutting ring 6L/S	rondelle de matrice
			580	N7430	Überwurfmutter	screw cap	écrou-chapeau
			590	N3616	Rohr	stainless steel tube 6x1	tuyau en acier inox 6x1
			610	80747*	Gleichrichter	rectifier	redresseur
			620	81673	Halterung	bracket	fixation
			630	81673-01*	Halterung	bracket	fixation

 Wartungssätze  
 Maintenance sets  
 Kits d'entretien

**Baugruppe** 80571  
**Assembly** 80571  
**Assemblage** 80571

**Kondensatablaßventil kpl. (Zusatzausstattung)**  
**Condensate drain valve assy. (optional extra)**  
**Soupape de purge des condensats cpl. (optionnelle)**
**TM320-25a**

Klasse/ Class/ Classe			Pos.	Bestell-Nr. Part No. No. de cde.	Benennung	Designation	Dénomination
a	b	c					
			5	064008	Kondensatventil	condensate drain valve	soupape de purge des condensats
			10	064009	Kondensatventil	condensate drain valve	soupape de purge des condensats
			20	N638	O-Ring	o-ring	joint torique
			30	N19538	Zylinderschraube	allen screw	vis à six pans creux
			40	N20003	W-Einschraubstutzen	male elbow	coude
			50	79969	Sammelleiste	manifold	collecteur
			60	N20018	G-Einschraubstutzen	screwed socket	raccord
			70	N52	Verschlußschraube	plug	bouchon fileté
			75	N1316	Dichtring	gasket	joint
			80	N15952	G-Einschraubstutzen	straight male connector	raccord
			90	N20237	G-Einschraubstutzen	straight male connector	raccord
			100	78791	Drosselverschraubung	choking connector	raccord d'étranglement
			110	N20065	G-Einschraubstutzen	straight male connector	raccord

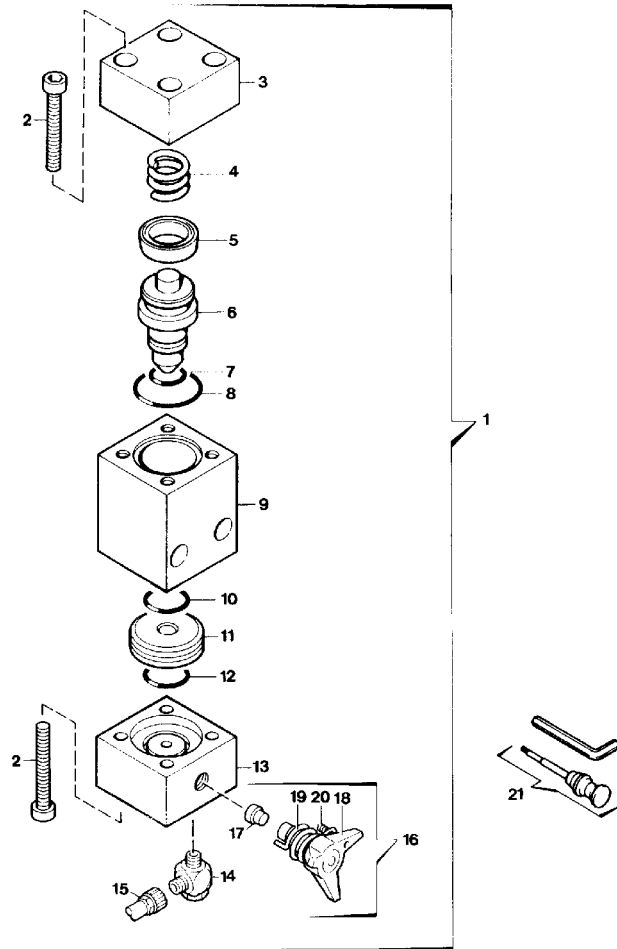

064008/08/98

 Wartungssätze  
 Maintenance kits  
 Kits d'entretien

**Baugruppe** 064008 **Kondensatablaßventil**  
**Assembly** 064008 **Condensate drain valve**  
**Assemblage** 064008 **Soupape de purge**
**TM320-25b**

Klasse/ Class/ Classe			Pos.	Bestell-Nr. Part No. No. de cde.	Anz. Qty. Qté.	Benennung	Designation	Dénomination
a	b	c						
			1	064008	1	Kondensatablaßventil	Condensate drain valve	Soupape de purge
			2	N19536	8	Innensechskantschraube	Allen screw	Vis à six pans creux
			3	64000	1	Kopfteil	Top flange	Bride supérieure
			4	64011	1	Feder	Spring	Ressort
X			5	N16269	1	Nutring	Sealing ring	Bague d'étanchéité
	X		6	64003	1	Kolben	Piston	Piston
X			7	N638	1	O-Ring	O-ring	Joint torique
X			8	N4881	1	O-Ring	O-ring	Joint torique
			9	64001	1	Mittelteil	Valve body	Corps de soupape
X			10	N2507	1	O-Ring	O-ring	Joint torique
X			11	64005	1	Ventilsitz	Valve seat	Siège de soupape
X			12	N4496	1	O-Ring	O-ring	Joint torique
			13	64002	1	Fußteil	Base flange	Bride inférieure
			14	N16334	1	Schwenkverschraubung	Adjustable male branch T	Raccord en T orientable
			15	N15088	1	Schlauch	Hose	Tuyau
			16	065500	1	Knebelschraube kpl.	Drain tap assy.	Robinet cpl.
			17	64498	1	Dichtung	Gasket	Joint
			18	11392	1	Knebelschraube	Drain tap	Robinet
			19	65310	1	Schenkelfeder	Spring	Ressort à broches
			20	N16947	1	Gewindestift	Stud	Vis sans tête
			21	067458	1	Werkzeugsatz f. Knebelschraube	Tool set for drain tap	Jeu d'outils pour robinet



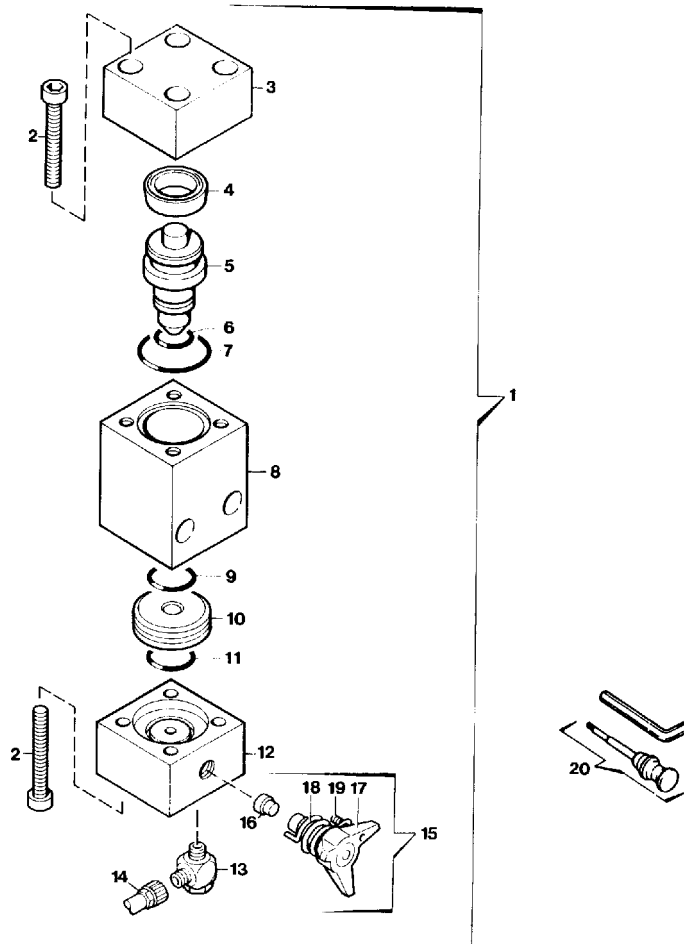

064009/08/98

 Wartungssätze  
 Maintenance kits  
 Kits d'entretien

**Baugruppe** 064009 **Kondensatablaßventil**  
**Assembly** 064009 **Condensate drain valve**  
**Assemblage** 064009 **Soupape de purge**
**TM320-25c**

Klasse/ Class/ Classe			Pos.	Bestell-Nr. Part No. No. de cde.	Anz. Qty. Qté.	Benennung	Designation	Dénomination
a	b	c						
			1	064009	1	Kondensatablaßventil	Condensate drain valve	Soupape de purge
			2	N19536	8	Innensechskantschraube	Allen screw	Vis à six pans creux
			3	64000	1	Kopfteil	Top flange	Bride supérieure
	X		4	N16269	1	Nutring	Sealing ring	Bague d'étanchéité
		X	5	64003	1	Kolben	Piston	Piston
	X		6	N638	1	O-Ring	O-ring	Joint torique
	X		7	N4881	1	O-Ring	O-ring	Joint torique
			8	64001	1	Mittelteil	Valve body	Corps de soupape
	X		9	N2507	1	O-Ring	O-ring	Joint torique
	X		10	64005	1	Ventilsitz	Valve seat	Siège de soupape
	X		11	N4496	1	O-Ring	O-ring	Joint torique
			12	64002	1	Fußteil	Base flange	Bride inférieure
			13	N16334	1	Schwenkverschraubung	Adjustable coupling	Raccord orientable
			14	N15088	1	Schlauch	Hose	Tuyau
			15	065500	1	Knebelschraube kpl.	Drain tap assy.	Robinet cpl.
			16	64498	1	Dichtung	Gasket	Joint
			17	11392	1	Knebelschraube	Drain tap	Robinet
			18	65310	1	Schenkelfeder	Spring	Ressort à broches
			19	N16947	1	Gewindestift	Stud	Vis sans tête
			20	067458	1	Werkzeugsatz f. Knebelschraube	Tool set for drain tap	Jeu d'outils pour robinet

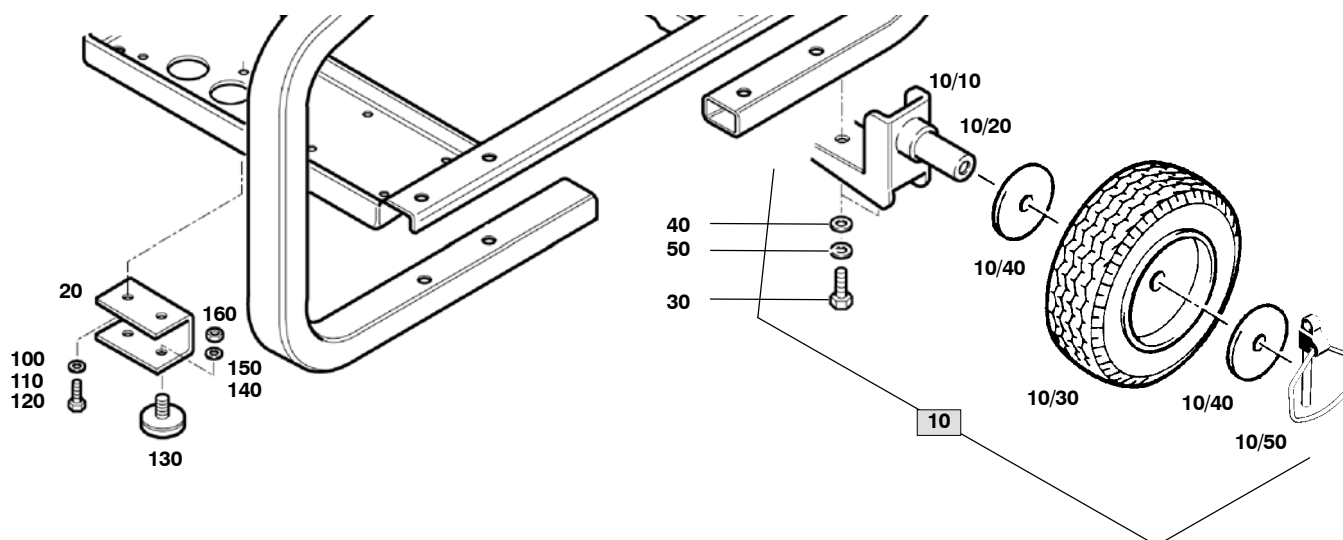

 Wartungssätze  
 Maintenance sets  
 Kits d'entretien

**Baugruppe** 80775  
**Assembly** 80775  
**Assemblage** 80775

**Fahrsatz (Zusatzausstattung)**  
**Undercarriage (optional extra)**  
**Chariot (option)**
**TM320-26**

Klasse/ Class/ Classe			Pos.	Bestell-Nr. Part No. No. de cde.	Benennung	Designation	Dénomination
a	b	c					
			10	80769	Fahrsatz	Undercarriage	Chariot
			20	80769-03	Halterung	bracket	fixation
			30	N19496	Sechskantschraube	screw	vis
			40	N102	Scheibe	washer	rondelle
			50	N100	Federring	spring washer	rondelle-ressort
			100	N58	Scheibe	washer	rondelle
			110	N108	Federring	spring washer	rondelle-ressort
			120	N19506	Sechskantschraube	screw	vis
			130	N1547	Schwingmetall	vibration isolator	silent-bloc
			140	N16	Scheibe	washer	rondelle
			150	N8999	Federring	lock washer	rondelle élastique
			160	N644	Sechskantmutter	hexagon nut self-locking	écrou hexagonal auto-freinant

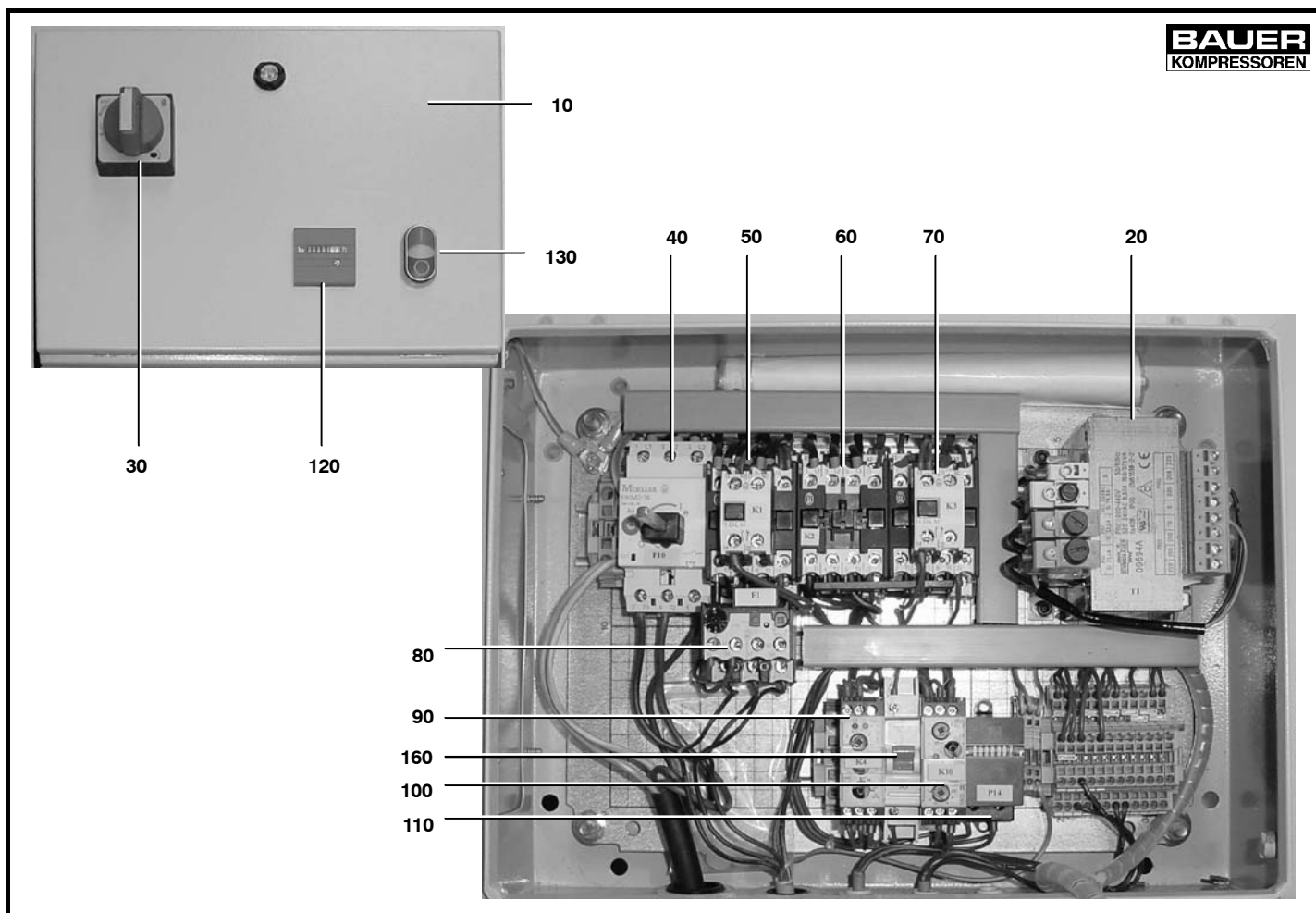
			10/10	80769-04*	Querstrebe	cross arm	
			10/20	80769-02*	Achse	axle	axe
			10/30	N3772	Rad	wheel	roue
			10/40	N1222	Scheibe	washer	rondelle
			10/50	N26639	Splint	split	goupille

 Wartungssätze  
 Maintenance sets  
 Kits d'entretien

**Baugruppe** 80752  
**Assembly** 80752  
**Assemblage** 80752

**Elektr. Steuerung (Zusatzausstattung)**  
**Electric control system (optional extra)**  
**Commande électrique (option)**
**TM320-27**

Klasse/ Class/ Classe			Pos.	Bestell-Nr. Part No. No. de cde.	Benennung	Designation	Dénomination
a	b	c					
			10	80744	Gehäuse	switch box	boîtier
			20	N26301	Transformator T1	transformer T1	transformateur T1
			30	N26569	Drehantrieb f. Leistungsschalter	actuator for power switch	poignée d'interrupteur
			40	N26570	Leistungsschalter F10	power switch F10	interrupteur de puissance F10
			50	N26571	Motorschütz K1	motor relay K1	disjoncteur moteur K1
			60	N26572	Motorschütz K2	motor relay K2	disjoncteur moteur K2
			70	N26573	Motorschütz K3	motor relay K3	disjoncteur moteur K3
			80	N26574	Überlastrelais F1	overload relay F1	relais de surcharge F1
			90	N16201	Zeitrelais K4	time relay K4	temporisateur K4
			100	N16202	Taktgeber K10	timer K10	minuterie K10
			110	N19096	Zyklenzähler P14	cycle counter P14	compteur de cycles P14
			120	N23853	Betriebsstundenzähler	hourmeter	compteur horaire
			130	N26308	Tastschalter S1	pushbutton switch S1	interrupteur S1
			160	N16206	Service-Schalter S3	service switch S3	interrupteur de service S3



